

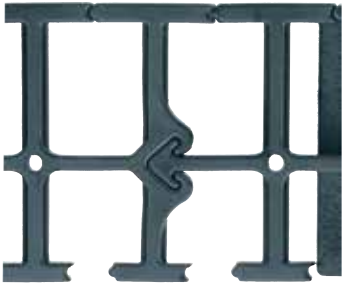

igus[®]
System T3
E3
E6-1
E6

T3



System T3 - Highly flexible, low vibration band chain without pin and bore connection

- For short strokes with extreme demands in low noise and dynamics
- For high speed and high accelerations
- Very low weight
- Hardly any abrasion
- Cost efficient, 3-piece e-chain®

System T3 ►



E3

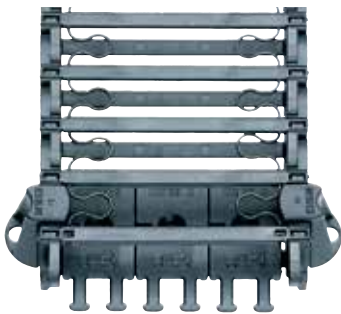

System E3 - Elastic, dampening connector strip replaces pins and bores

- Extremely low noise e-chain® for small spaces with modular 3-piece link design
- 3 sizes available
- Inner heights: .39" (10 mm), .59" (15 mm), .87" (22 mm)

System E3 ►



E6-1



System E6-1 - Connector replaces pins and bores

- Low noise - from a noise level of 32 dB(A)
- 30% Lighter than the System E6
- 4 sizes available
- Inner heights: 1.14" (29 mm), 1.38" (35mm), 1.57" (40 mm), 2.05" (52 mm)

System E6 ►



E6



System E6 - Connector replaces pins and bores

- Extremely low noise e-chain® with high stability and tensile strength
- Modular 6-piece link design
- 5 sizes available
- 3 types available (e-chain®, E-Tube, Light version)
- Inner heights: 1.14" (29 mm), 1.57" (40 mm), 2.05" (52 mm), 2.44" (62 mm), 3.15" (80 mm)

System E6 ►



e-chain system® T3, E3, E6-1 and E6

The extremely low noise igus® e-chain® - System E3, System E6 and System T3

The e-chain® of the E3, E6 and T3 Series have extremely good low noise and vibration performance. The special, abrasion-resistant spring elements replace the conventional pin and bore connection of the chain links enabling the low noise and low vibration operation of the e-chain®. Due to the special fastening system, these e-chains® have minimal wear and abrasions and are therefore suitable for cleanroom applications.

Another advantage of the connector is that in the application of an electrically conductive material it can guarantee constant conductivity value. The e-chain® Series E3, E6 and T3 offer an extensive accessories package and are available in many sizes off the shelf.

Measurement values of sound pressure levels dB(A) in comparison

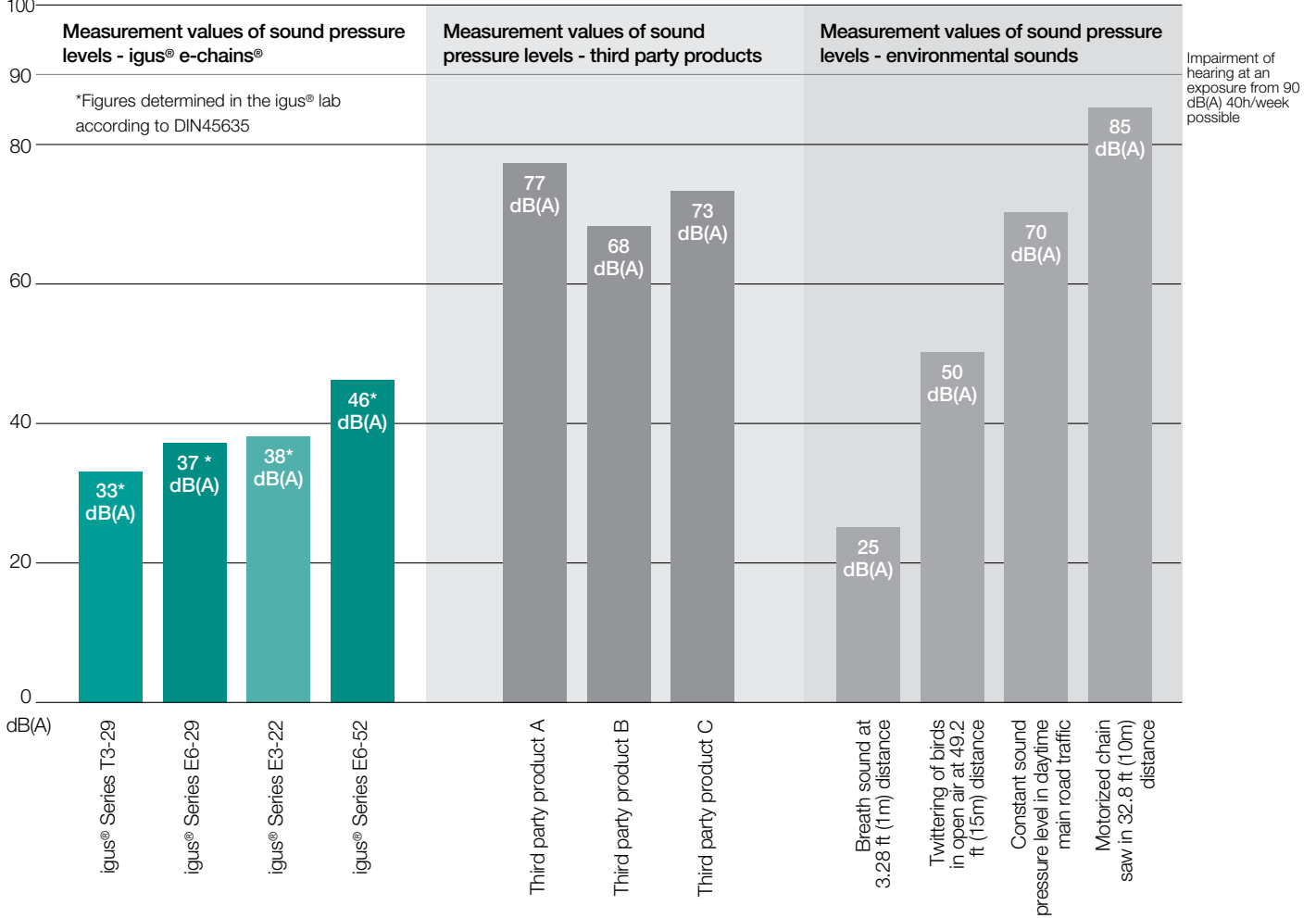

Results of measurement

Particle generation measurement:

For a total of 100 minutes, the air around the moving test object is analyzed for particles.

Result: NO particles larger $\geq 0.2 \mu\text{m}$ were measured.

Result according to DIN EN ISO 14644-1	e-chain® Series	Report No.	Speed ft/s (m/s)
ISO Class 1	E3-15-040-075-0	IG0704-400	1.64 / 3.28 / 6.56 (0.5 / 1.0 / 2.0)
ISO Class 1	E6-29-060-150-CR	IG0704-400	1.64 / 3.28 / 6.56 (0.5 / 1.0 / 2.0)
ISO Class 1	E61-29-050-075-0	IG1303-640-1	1.64 / 3.28 / 6.56 (0.5 / 1.0 / 2.0)
ISO Class 2	T3-29-050-038-0	IG1303-640-1	1.64 / 3.28 / 6.56 (0.5 / 1.0 / 2.0)
ISO Class 3	E6-29-060-150-0	IG0704-400	1.64 / 6.56 (0.5 / 2.0)



e-chain systems® E6-1, E3, E6.29.CR certified according to DIN EN ISO 14644-1 Class 1, by the Fraunhofer IPA Institute.

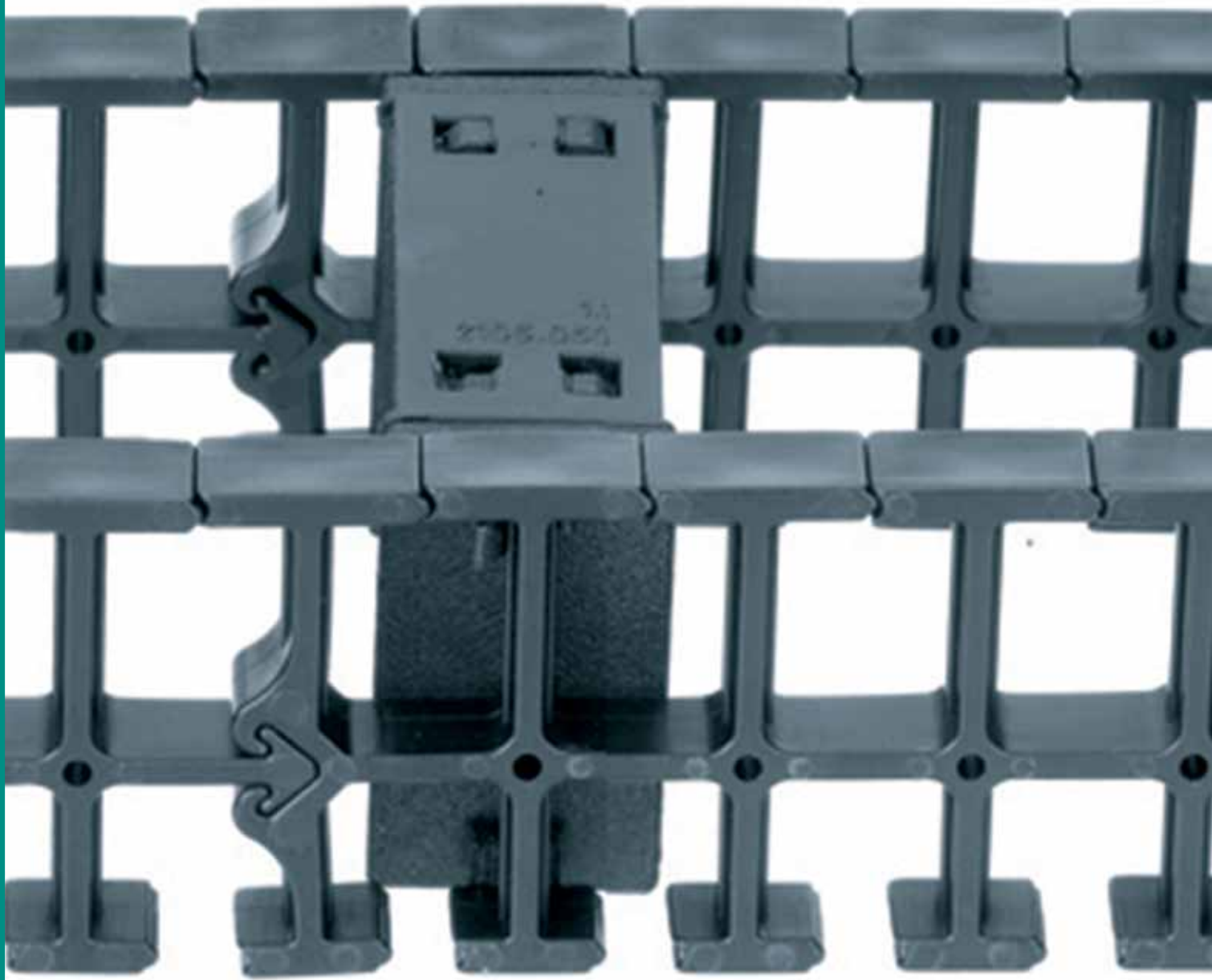

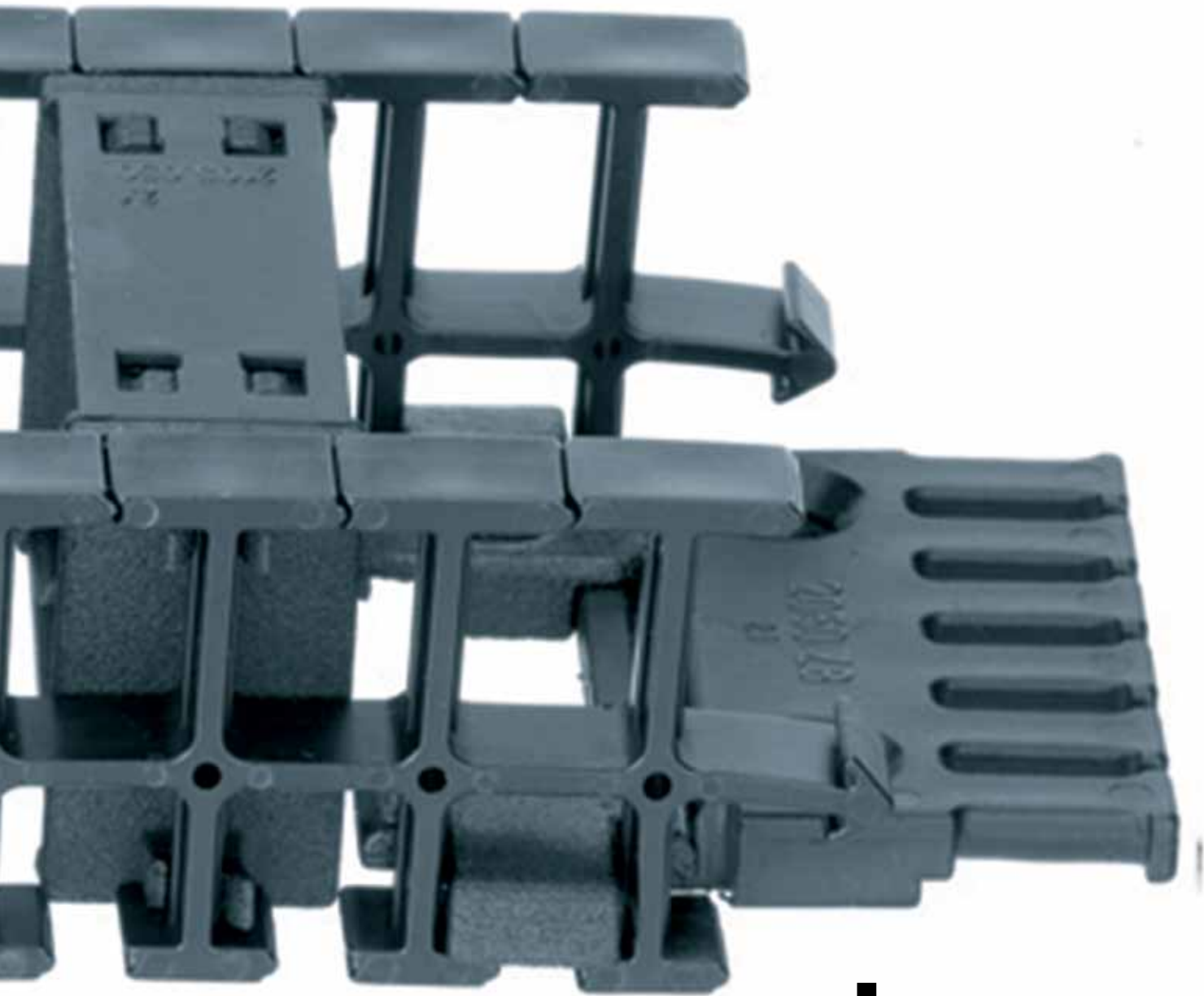

igus[®]
System T3
Highly flexible & low-vibration

System T3 - Highly flexible, low vibration band chain

The T3-System combines low-noise operation, low sound level, simple installation and economy. The side plates that can be plugged into each other replace the conventional pin and bore connection and prevent relative movements between the joints, giving an almost complete freedom from wear. By the unique geometrical shape of the T-band, hardly any polygon effect is generated in operation. The T-band operates in a very smooth arc giving extremely low vibration and noise. In order to reduce the manufacturing and installation costs, the T-band is mounted in a length of 8 chain links. Due to its low mass, the igus® T-band, combined with high speeds and accelerations, is suitable for applications with low fill weights and short strokes.

Typical industries and applications

- Printer and plotter
- Cleanroom applications
- Production and processing of semiconductors
- Optics
- Automatic insertion machines
- Measuring technology



igus® tests at 3.28 ft (1 m) measuring distance: = 33 dB(A) for T3-29-050-038-0 at $v = 3.28$ ft/s (1 m/s) and 26.5 dB(A) basic sound level



Cleanroom test upon request



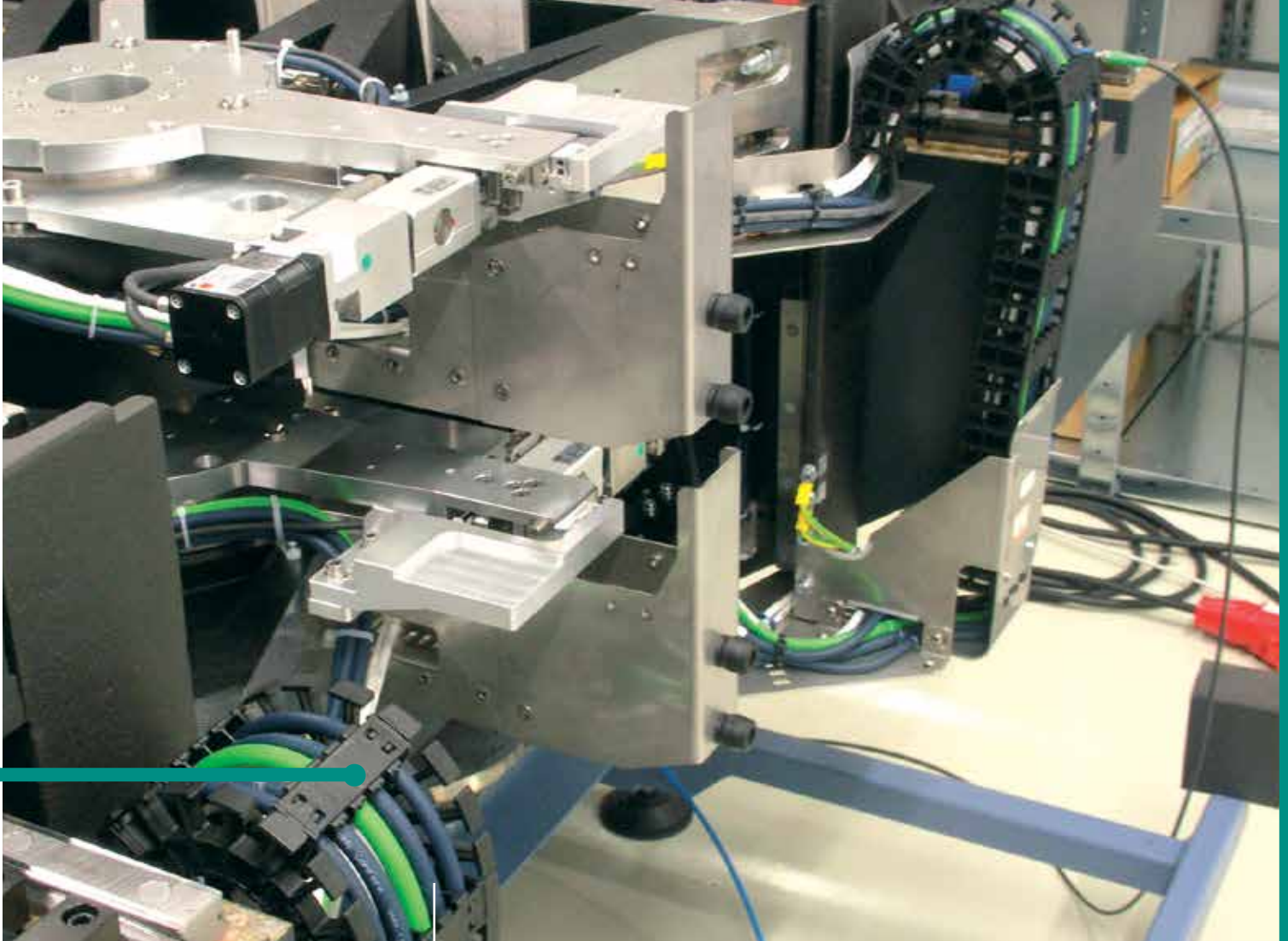

T3 system on the Z-axis in the positioning system. It has very low vibration and is quiet.



Testing facility at the igus® laboratory System T3 - ideal for high accelerations and short strokes

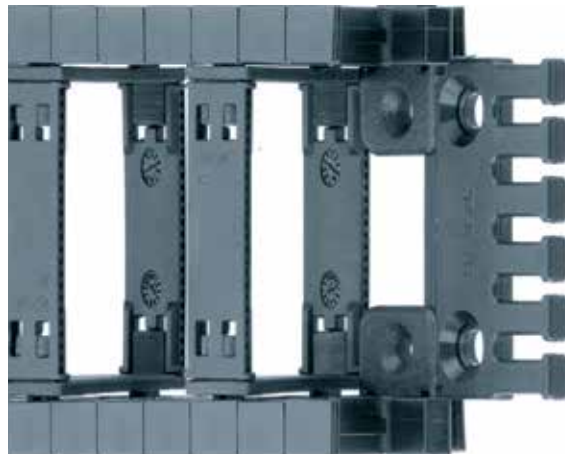

igus® System T3 T band chain - Inner height 1.14" (29 mm)

Next Page ► Find selection table and assembly instructions

e-chain[®] T3 Selection Guide

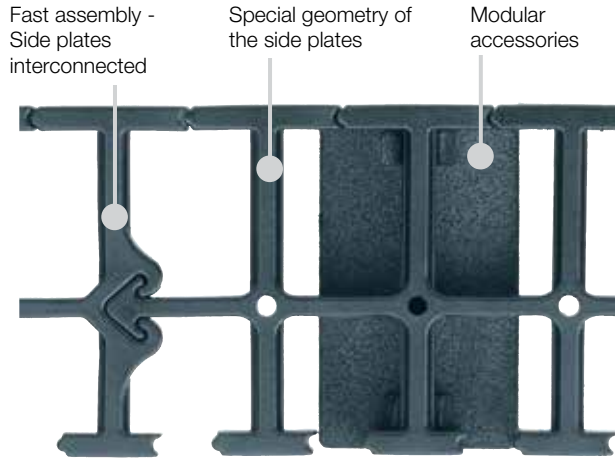

T3: e-chain[®] band for highly dynamic applications

In the development of the 3-piece, T-shaped band chain “T3”, the main focus was on minimum operational noise with lowest cost. This is achieved by the side-plate band consisting of 8 chain links in one piece, as well as the use of existing components of the popular E6 range. Due to the short pitch of the links, the curve section of the e-chain remains fairly round. The omission of a pin and bore connection means the T3 band chain features extremely low abrasion and wear and hence is good for cleanroom applications.

- Extremely low noise and low vibration
- Low-priced e-chain[®] for simple applications
- For high speeds and accelerations
- Very low weight
- Hardly any abrasion
- For short strokes
- Accessories: Separators, integrated strain relief, mounting brackets
- You can find more technical data about the material, chemical resistance, temperatures ► **Design, Section 1**

Series	Inner height <i>hi</i> in. (mm)	Inner width <i>Bi</i> in. (mm)	Outer width <i>Ba</i> in. (mm)	Outer height <i>ha</i> in. (mm)	Bending radius <i>R</i> in. (mm)
T3-29	1.14 (29)	1.18-5.51 (30-140)	2.17-6.50 (55-165)	1.38 (35)	1.50 (038)



Available from stock. Orders ship as early as today.*

*On average 90% of orders ship the same day..

e-chain system® T3 Assembly Instructions

System T3 - 3-piece e-chain®

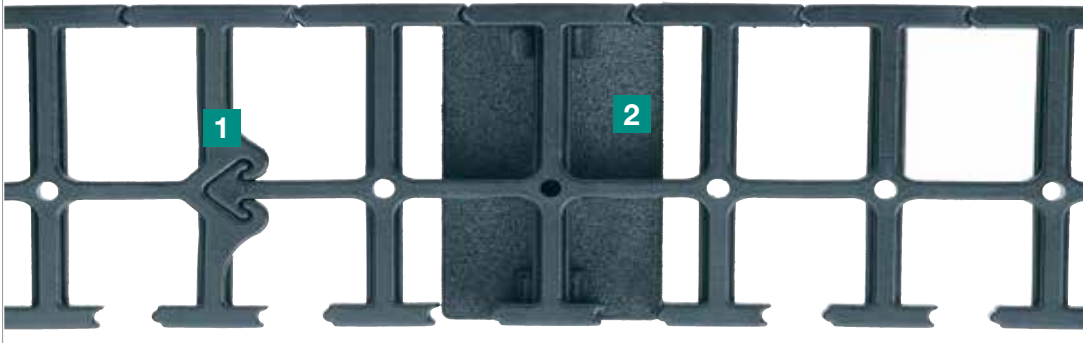

The abbreviation "T3" stands for a T-shaped E band, which consists of three basic elements:

- ❶ 2 side-plate bands (left/right)
- ❷ Separator element including separators

System T3 - Assembling



Side plates to be plugged into each other



Clip-on "interior separation clips"



System T3 enables quick installation times. The side plates can be simply plugged in

System T3 - Interior Separation and Strain Relief



Separators for dividing the chain cross section from the proven and tested E6 range (E6-29)

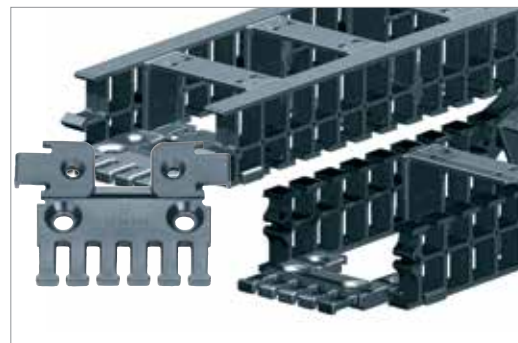

Universal strain relief through optional mounting angle. You can attach the e-chain® at the fixed end, if necessary

Price Index

Series T3-29

Special Features / Options

Extremely low noise
 Test results upon request

Clean-room
 Cleanroom test upon request

Assembly Tips

Fast assembly due to side link strip

Usage Guidelines



- At very high speeds and/or accelerations
- If a very light e-chain® is required
- If a particularly low-cost e-chain® is required
- For small bending radii and small spaces
- If easy filling and assembly is required
- Minimal abrasion (e.g. cleanroom applications)



- When an e-chain® is required for more fill weight
 ► **Series E6-29**
- When an enclosed e-chain® is required for low noise operation
 ► **Series R6-29**

Features & Benefits

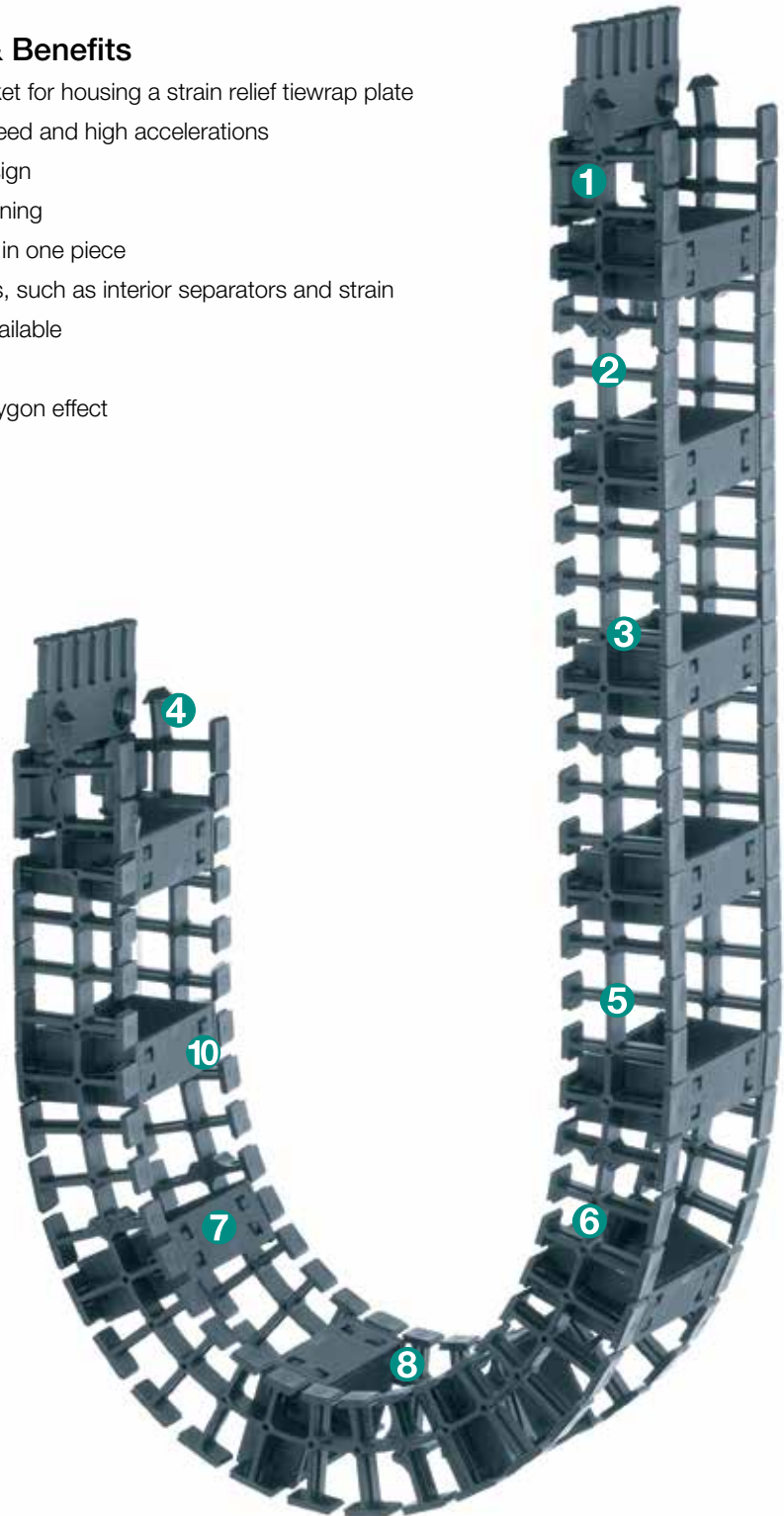
- 1 Angle bracket for housing a strain relief tiwrap plate
- 2 For high speed and high accelerations
- 3 3-piece design
- 4 Easy shortening
- 5 Side plates in one piece
- 6 Accessories, such as interior separators and strain relief are available
- 7 Low weight
- 8 Minimal polygon effect

Order Example: Complete e-chain®

Please indicate chain length or number of links. Example:

3.28 ft (1 m) **T3-29-050-038-0****e-chain®**With 2 separators **29-1-1** assembled every 2nd link**Interior Separation**1 Set **T3-29-050-12****Mounting Bracket**

e-chain system® T3

Series T3-29

Installation Dimensions



T3-29

Short travel, unsupported length

- FL_B = unsupported with permitted sag
 - FL_G = unsupported with straight upper run
- Further information ► Design, Chapter 1

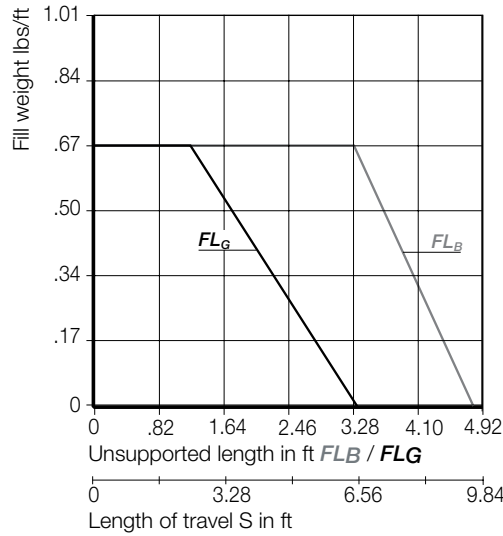
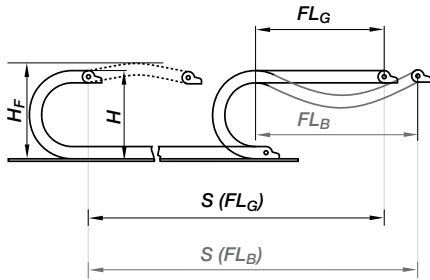

Short Travels - Unsupported

Unsupported e-chains® feature positive camber over short travels. This must be accounted for when specifying the clearance height. Please refer to **Installation dimensions** for further details.

Legend

- S = Length of travel
- R = Bending radius
- H = Nominal clearance height
- D = Overlength e-chain® radius in final position
- $K = \pi \cdot R + \text{safety buffer}$
- H_f = Required clearance height

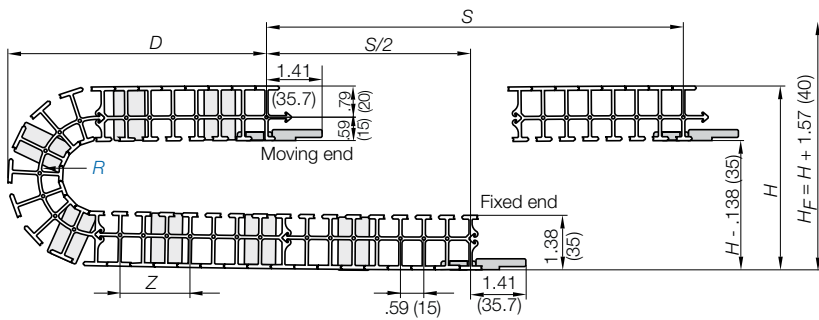

Pitch per link = $.59^\circ$ (15 mm)
 Links per ft (m) = 20 (67)
 For center mount applications:
 Chain length = $\frac{S}{2} + K$

The required clearance height: $H_f = H + 1.57$ in. (40 mm) (with 0.67 lbs/ft (1.0 kg/m) fill weight). Please consult igus® if space is particularly restricted.

R	1.50 (038)
H	8.50 (216)
D	4.57 (111)
K	8.27 (210)

Speed / acceleration FL_G	max. 65.6 ft/s (20 m/s) / max. 656 ft/s ² (200 m/s ²)
Speed / acceleration FL_B	max. 9.84 ft/s (3 m/s) / max. 19.69 ft/s ² (6 m/s ²)
Gliding speed / acceleration (maximum)	upon request
Permitted temperature	-40°F (-40°C) up to +158°F (+70°C)
Flammability Class	VDE 0304 IIC UL94 HB

Technical Data



Details of material properties

► Design, Chapter 1

29

PDF: igus.com/e-chain-pdfs
 Product information: igus.com/e-chains

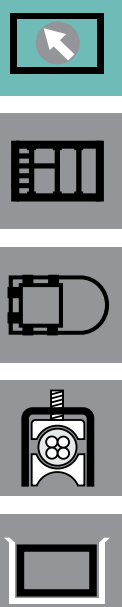

Series T3-29 - e-chain® with crossbars every other link

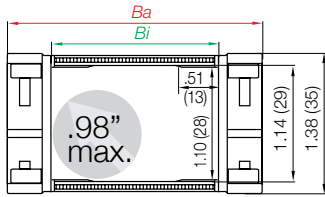

Part Number Structure

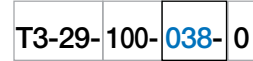

- Color - Black
- Bending radius
- Width
- Series

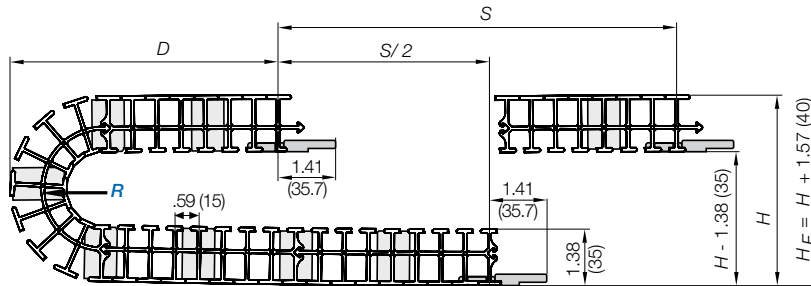

Supplement part number with required radius. Example: T3-29-100--0
Pitch: .59 in. (15 mm) per link links/ft (m) = 20 (67)

Part Number	Bi in. (mm)	Ba in. (mm)	Weight lbs/ft (kg/m)
T3-29-030- <input type="text" value=""/> -0	1.18 (30)	2.16 (55)	≈ 0.27 (0.40)
T3-29-040- <input type="text" value=""/> -0	1.57 (40)	2.56 (65)	≈ 0.28 (0.42)
T3-29-050- <input type="text" value=""/> -0	1.97 (50)	2.95 (75)	≈ 0.30 (0.44)
T3-29-060- <input type="text" value=""/> -0	2.36 (60)	3.35 (85)	≈ 0.31 (0.46)
T3-29-070- <input type="text" value=""/> -0	2.76 (70)	3.74 (95)	≈ 0.32 (0.48)
T3-29-080- <input type="text" value=""/> -0	3.15 (80)	4.13 (105)	≈ 0.34 (0.50)
T3-29-090- <input type="text" value=""/> -0	3.54 (90)	4.53 (115)	≈ 0.34 (0.51)
T3-29-100- <input type="text" value=""/> -0	3.94 (100)	4.92 (125)	≈ 0.36 (0.53)
T3-29-110- <input type="text" value=""/> -0	4.33 (110)	5.31 (135)	≈ 0.37 (0.55)
T3-29-120- <input type="text" value=""/> -0	4.72 (120)	5.71 (145)	≈ 0.38 (0.57)
T3-29-140- <input type="text" value=""/> -0	5.51 (140)	6.50 (165)	≈ 0.40 (0.59)

Choose from the radii below for all of the above sizes
Radius (mm) Example: T3-29-100--0

<input type="text" value="038"/>
R 1.50 (038)
H 8.50 (216)
D 4.57 (111)
K 8.27 (210)



Interior separation elements

Distance "Z" for the interior separation elements of the T3 e-chain®

Note: The first and last chain links should not have interior separation elements! As a standard, crossbars are mounted on every 4th chain link!

Part No.

For other distances, e.g. every 6th chain link, change the part number as follows:

Part No.

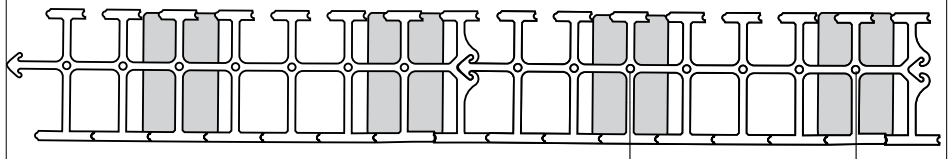

e-chain system® T3
Series T3-29
Interior Separation - New Generation



T3-29

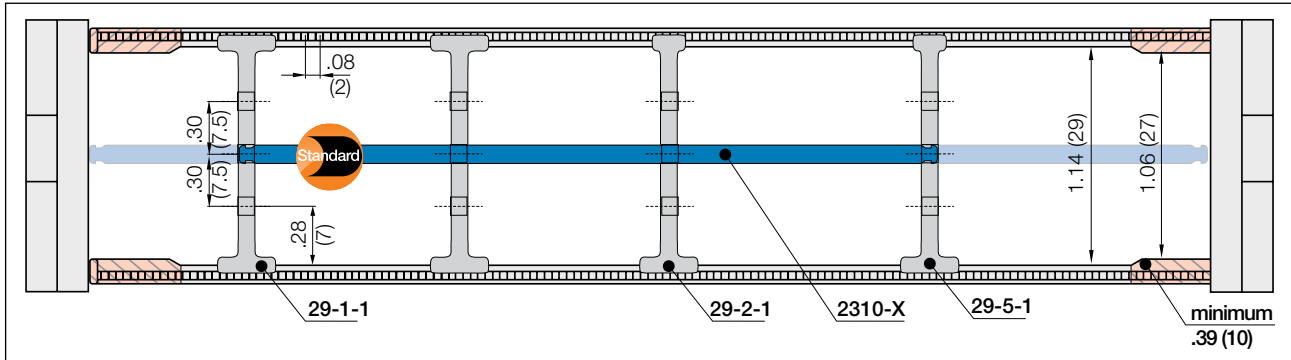

Note: Please maintain a lateral spacing of .39" (10 mm) between the separators and the side links.

In the standard configuration separators are assembled every 2nd e-chain® link

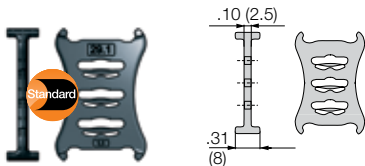

Separator, wide base

Unassembled	Part No. 29-1
Assembled	Part No. 29-1-1

- **Standard separator 29-1**
for all applications

Separator with wide base for maximum locking strength and safe standing in e-chains®.

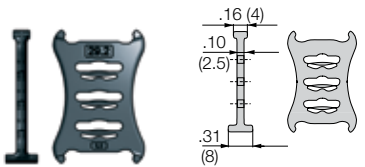

Separator, narrow head

Unassembled	Part No. 29-2
Assembled	Part No. 29-2-1

- **Separator 29-2**
For even faster installation

Firm hold to one side with a wide base, narrow on opposed side for easy cable assembly (slight grip)

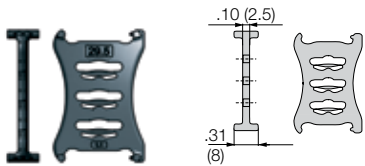

Separator, narrow base

Unassembled	Part No. 29-5
Assembled	Part No. 29-5-1

- **Notch separator 29-5**

Notch separator for exact positioning in e-chains®. Recommended for side mounted applications

Lockable full-width shelves - for the standard interior separation

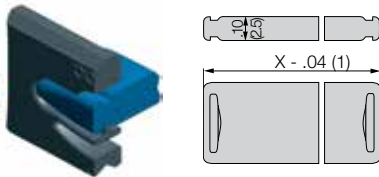

Full width shelf, lockable

Unassembled	Part No. 2300-X
Assembled	Part No. 2310-X

- **Full width shelf, lockable**

Full-width shelf locks safely into the separators on both ends, fixed width possible. Separators can be moved freely over the shelf in horizontal direction. Shelves can be arranged at 3 different heights.

Width X in. (mm)	Part No. Unassembled	Part No. Assembled	Width X in. (mm)	Part No. Unassembled	Part No. Assembled	Width X in. (mm)	Part No. Unassembled	Part No. Assembled
0.59 (015)	2300-015	2310-015	2.36 (060)	2300-060	2310-060	3.43 (087)	2300-807	2310-087
0.98 (025)	2300-025	2310-025	2.44 (062)	2300-062	2310-062	3.54 (090)	2300-090	2310-090
1.18 (030)	2300-030	2310-030	2.56 (065)	2300-065	2310-065	3.94 (100)	2300-100	2310-100
1.50 (038)	2300-038	2310-038	2.76 (070)	2300-070	2310-070	4.06 (103)	2300-103	2310-103
1.57 (040)	2300-040	2310-040	2.95 (075)	2300-075	2310-075	4.33 (110)	2300-110	2310-110
1.97 (050)	2300-050	2310-050	3.03 (077)	2300-077	2310-077	4.72 (120)	2300-120	2310-120
2.24 (057)	2300-057	2310-057	3.15 (080)	2300-080	2310-080	4.92 (125)	2300-125	2310-125

Separator with integrated strain relief

Strain relief separator Part No. E6-29-02-Z can be integrated into the mounting bracket and can be placed there at any point of the e-chain®. It combines strain relief and interior separation, it can be installed on the first or last e-chain® link and is easy to assemble without any screws.

For more information ► Chapter 10, Strain Relief



PDF: igus.com/e-chain-pdfs
Product information: igus.com/e-chains



Moving end
T3-29...2

Fixed end
T3-29...1

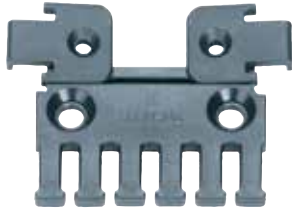
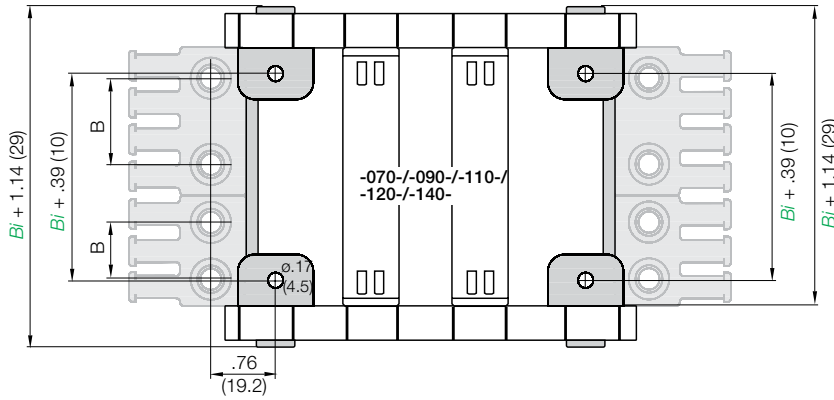
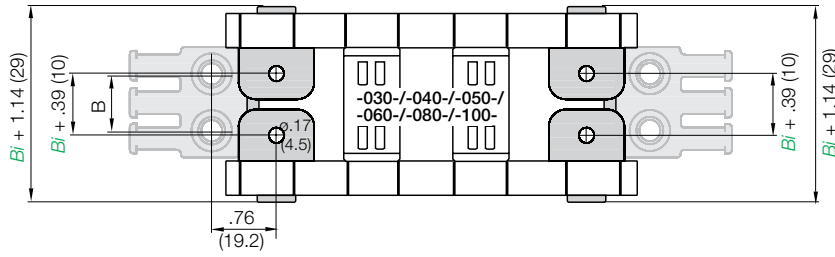

Mounting angle with strain relief



Mounting angle, single

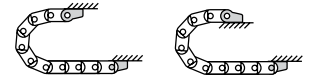

Possible installation configurations -

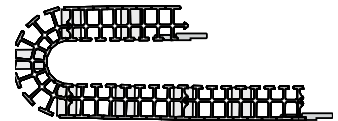

For Series	Part No. Full Set with tiewrap plate	Part No. Full Set without tiewrap plate	Bi in. (mm)	Dimension in. (mm)	Number of teeth
T3-29-030	T3-29-030-12PZ	T3-29-030-12	1.18 (30)	.59 (15)	3
T3-29-040	T3-29-040-12PZ	T3-29-040-12	1.57 (40)	.79 (20)	4
T3-29-050	T3-29-050-12PZ	T3-29-050-12	1.97 (50)	1.18 (30)	5
T3-29-060	T3-29-060-12PZ	T3-29-060-12	2.36 (60)	1.57 (40)	6
T3-29-070	T3-29-070-12PZ	T3-29-070-12	2.76 (70)	1.38 (15+20)	7
T3-29-080	T3-29-080-12PZ	T3-29-080-12	3.15 (80)	2.36 (60)	8
T3-29-090	T3-29-090-12PZ	T3-29-090-12	3.54 (90)	1.97 (20+30)	9
T3-29-100	T3-29-100-12PZ	T3-29-100-12	3.94 (100)	3.15 (80)	10
T3-29-110	T3-29-110-12PZ	T3-29-110-12	4.33 (110)	2.75 (30+40)	11
T3-29-120	T3-29-120-12PZ	T3-29-120-12	4.72 (120)	3.14 (40+40)	12
T3-29-140	T3-29-140-12PZ	T3-29-140-12	5.51(140)	3.93 (60+40)	14

Part Number Structure

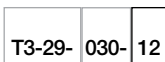

Complete Set
Width
Series

Full set, for both ends:

T3-29-030-12 Full set, both fixed and moving end

Single-part order:

T3-29-030-1 Mounting bracket fixed end

T3-29-030-2 Mounting bracket moving end

e-chain system® T3
 Series T3-29
 Strain Relief, Additional installation options



T3-29

Strain Relief

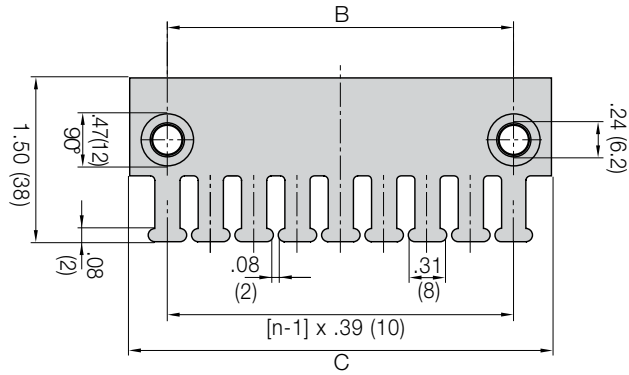
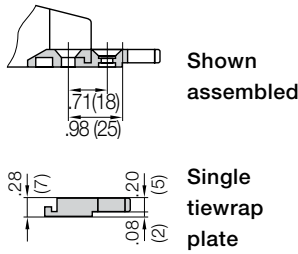

igus® chainfix tiewrap plate as individual part

Tiewrap Plates	n Number of Teeth	Dimension C	Dimension B	
2020-ZB	3	1.18 (30)	.59 (15)	
2030-ZB	4	1.57 (40)	.79 (20)	
2040-ZB	5	1.97 (50)	1.18 (30)	
2050-ZB	6	2.36 (60)	1.57 (40)	
2070-ZB	8	3.15 (80)	2.36 (60)	
2090-ZB	9	3.54 (90)	2.76 (70)	Use (2030-ZB + 2040-ZB)
2100-ZB	10	3.94 (100)	3.15 (80)	
2125-ZB	12	4.72 (120)	3.94 (100)	Use (2050-ZB + 2050-ZB)

Also available:
 Separator with integrated strain relief
 for use in the first or last chain link
(Part No. E6-29-02-Z)

➤ Strain Relief, Chapter 10



igus®
 e-chain system®

Telephone 1-800-521-2747

T3 e-chains® and modules for circular movement

T3 e-chains® for reverse bending radii (RBR)
 Part No. T3-29-050-38/55, T3-29-050-38-75, T3-29-050-38-100,
 T3-29-050-38-150

- Several reverse bending radii available in 55, 75, 100, and 150
- Quiet
- Low wear
- Several mounting positions
- Complete line of interior separation for Series T3-29



T3 RBR modules for reverse bending radii

Consists of 4 elements: T3 RBR e-chain®, guiding system, chainflex®
 motion cables, iglide® PRT slewing ring bearing
 Part No. T3-29-070-038/055

- Compact guiding module
- Able to turn in inner and outer radius
- For high speeds
- Quiet
- Compact dimensions
- Several mounting positions
- Delivery upon request

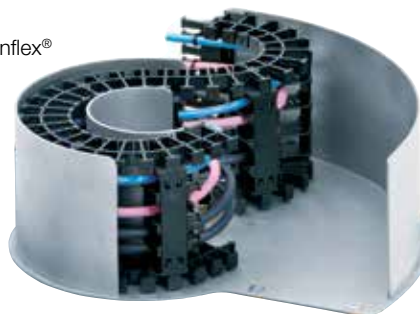

Internet: igus.com
 email: sales@igus.com
 QuickSpec: igus.com/quickspec

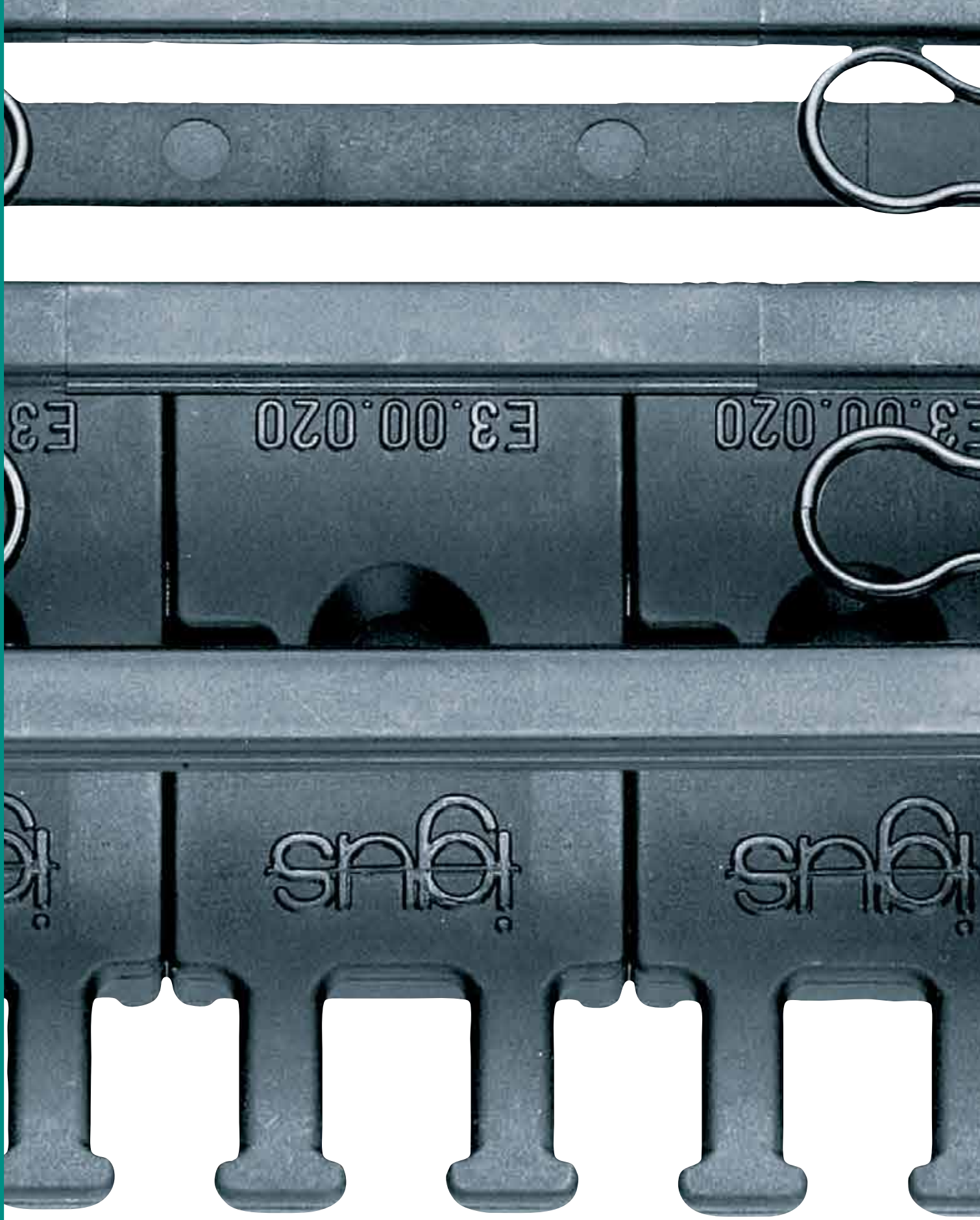



igus[®]
System E3
Highly dynamic &
cleanroom compatible

E3 - Highly dynamic and cleanroom compatible

The igus® System E3 combines small pitches, smooth running, low noise, stability, easy assembly and economic efficiency all in one. The spring connector element replaces the pin and bore design and avoids relative movements between the joints. This means virtually no wear or abrasion for cleanroom applications. To reduce production and assembling costs, the spring connector is not mounted individually, but on a length of ten chain links. Another E3 option is safe performance. A modified spring element made of electrically conductive material, which connects the chain links mechanically and electrically, permanently guarantees constant electrical conductivity, even at high bending stress and in any position.

Typical industries and applications

- Semi-conductor manufacturing and handling
- Pick and place robots
- Optics
- Materials handling technology
- Measuring technology
- Printers and plotters
- Cleanroom environments
- General mechanical engineering



IPA Qualification Certificate - Report IG0704-400:
ISO Class 1, according to Norm DIN EN ISO 14644-1
for System E3, Series E3-15-040-075-0 at
 $v = 1.64 \text{ ft/s (0.5 m/s), 3.28 ft/s (1 m/s), 6.56 ft/s (2 m/s)}$



38 dB(A) - Value determined at the igus® test-lab acc. to DIN 45635, with consideration of background noises, for Series E3-22-060-044-0 at $v = 5.91 \text{ ft/s (1.8 m/s)}$



iF-Design
Award 2005



Special equipment: Electrically conductive
ESD/ATEX version upon request

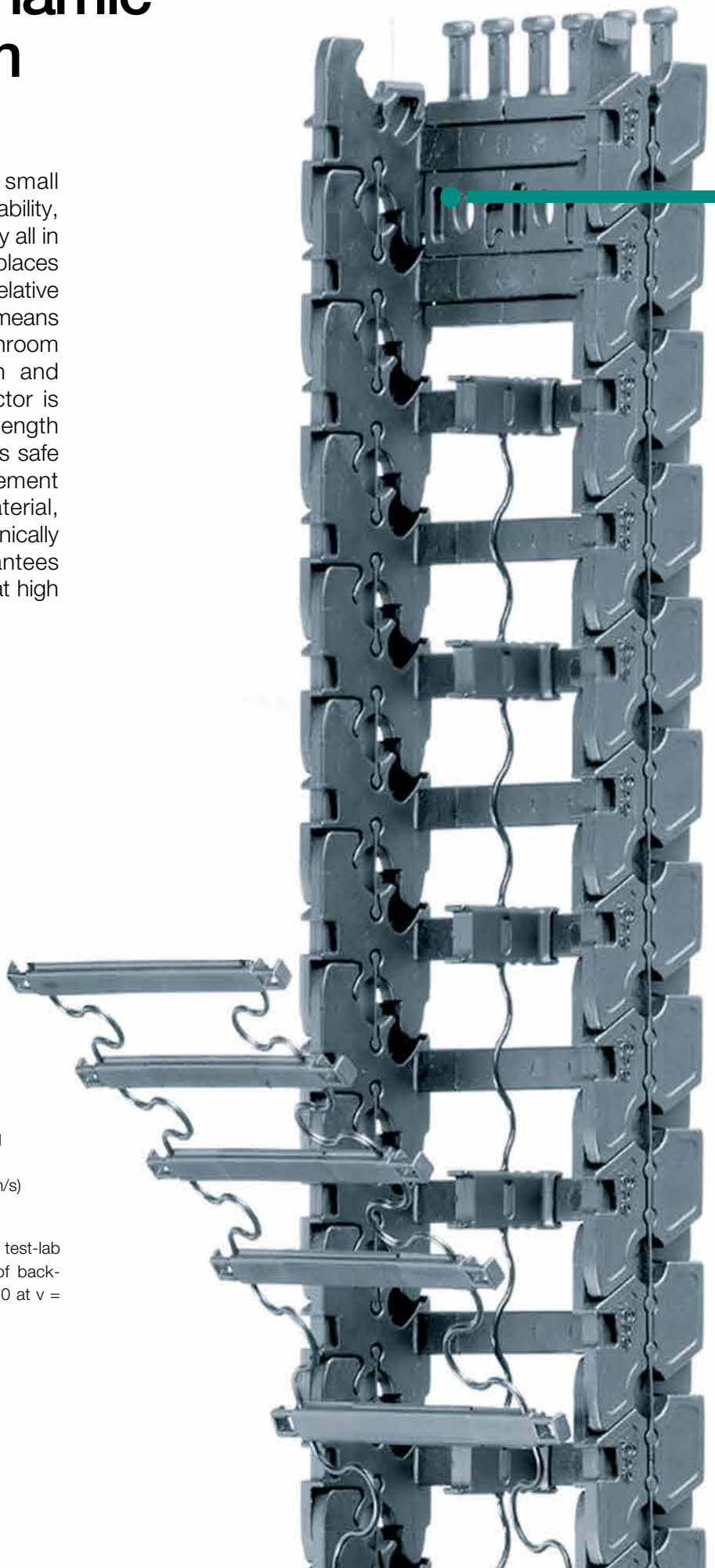

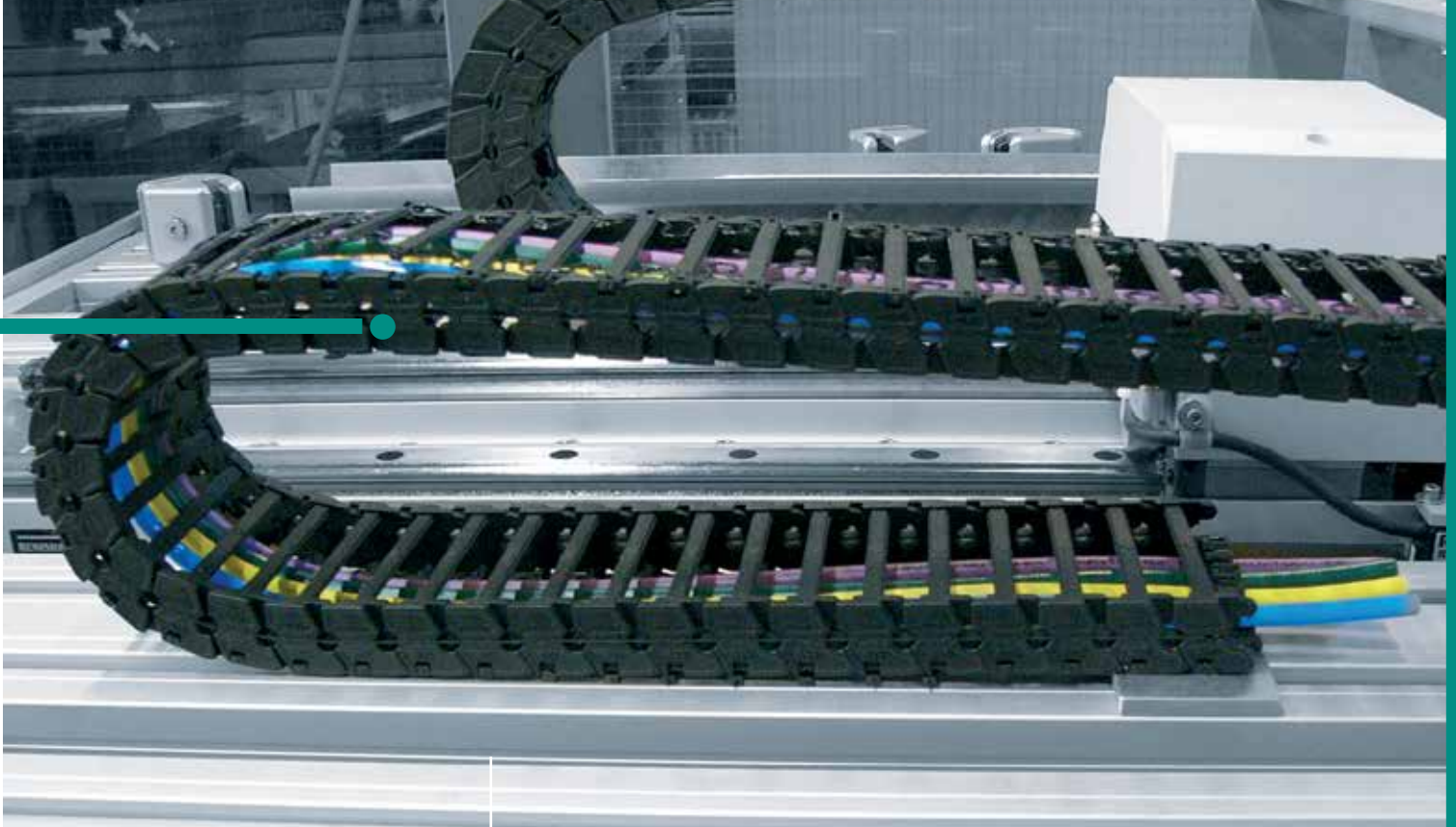

Long-term tests in our acoustics laboratory at a speed of 5.91 ft/s (1.8 m/s) and an acceleration of 9.84 ft/s² (3 m/s²) showed reductions of 19-20 dB(A) compared to conventional e-chains®.



Light-weight and super-silent in small spaces - System E3



During long-term tests the System E3 with the spring band connector easily passes 15 million cycles at a bending radius of 1.73" (44 mm) and an acceleration of 4 g

e-chain system® E3

Selection Guide

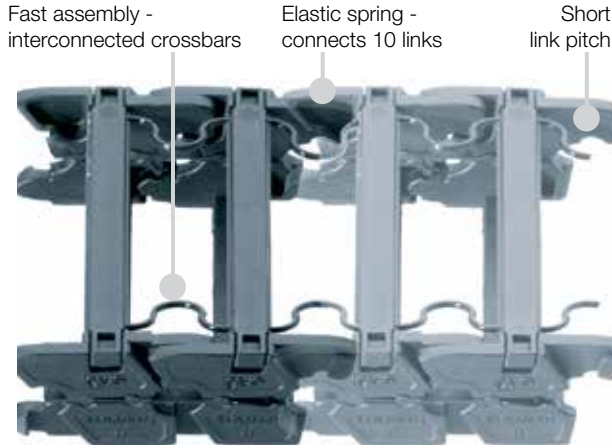

E3 = e-chains® with 3 different elements in one link:

- U-shaped link body
- Spring element
- Interconnected crossbars

E3: System for highly dynamic applications

Cycle times in automation get shorter, while demands for low noise and low vibration levels are increasing. For the broad range of small size e-chain® applications, igus® now introduces the System E3, that fully meets those requirements:

- Extremely low-noise operation - max. 38 dB(A)
- Elastic, dampening connector strip replaces pins and bores
- Modular 3-piece link design
- Cost effective cross bar, separator and connector modules
- Fast and easy cable access due to zipper opening mechanism
- Good unsupported strength due to solid, interlocking side links
- Easy lengthening and shortening
- Also suits flat cables
- Accessories: Separators, integrated strain relief, mounting brackets
- You can find more technical data about the material, chemical resistance, temperatures ► **Design, Chapter 1**

Series	Inner height <i>hi</i> in. (mm)	Inner width <i>Bi</i> in. (mm)	Outer width <i>Ba</i> in. (mm)	Outer height <i>ha</i> in. (mm)	Bending radius <i>R</i> in. (mm)
E3-10	.39 (10)	.79-2.36 (20-60)	1.26-2.83 (32-72)	.59 (15)	.59-1.89 (15-48)
E3-15	.59 (15)	.79-2.36 (20-60)	1.26-2.83 (32-72)	.79 (20)	1.26-2.95 (32-75)
E3-22	.87 (22)	.79-2.36 (20-60)	1.26-2.83 (32-72)	1.06 (27)	1.75-2.95 (44-75)



Available from stock. Orders ship as early as today.*

*On average 90% of orders ship the same day..

e-chain system® E3 Assembly Instructions

System E3 - 3-piece e-chain®

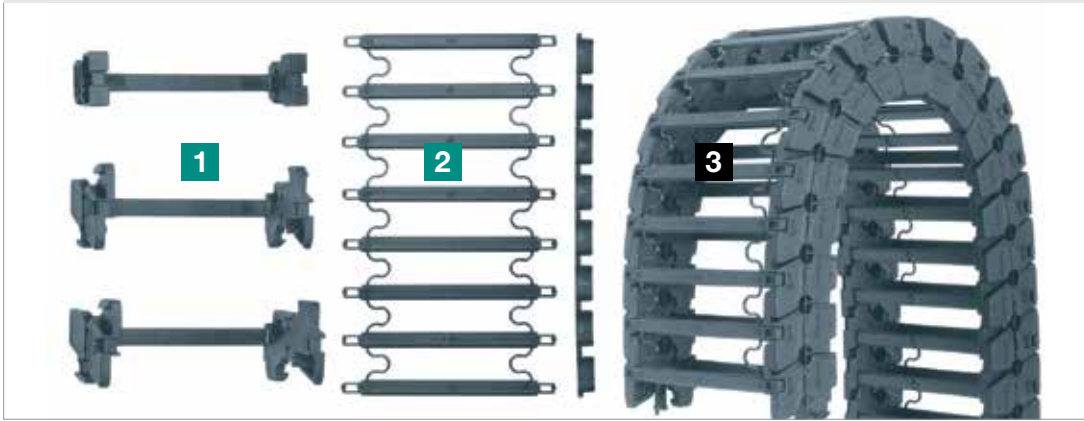

The abbreviation "E3" stands for an e-chain® consisting of three basic elements:

- ❶ e-chain® link body
- ❷ Interconnected crossbars
- ❸ Separator module

System E3 - Opening and Closing



Interconnected crossbars for quick and easy installation - This e-chain system® allows faster assembling times. Opening and closing the e-chain® is made easy by Interconnected crossbars

System E3 - Interior Separation and Strain Relief

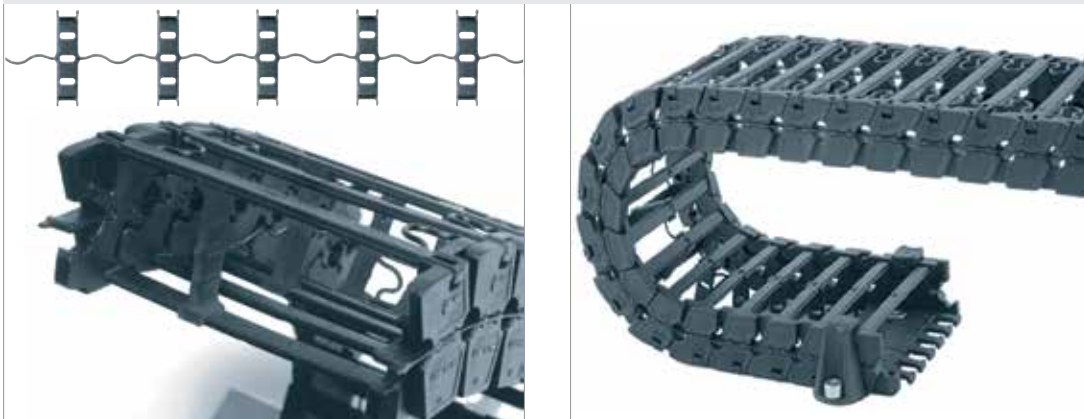

Vertical separators on a band divide carrier space - Five separators on one thread are simultaneously mounted on the crossbars

The universal strain relief can be individually matched to the chain width. You can fix the e-chain® on the fixed end with brackets (option)

Price Index

Series E3-10

Special Features / Options

*Noise test values: max. 38dB(A)
 - Values determined at the igus®
 test lab according to DIN 45635
 (v = 5.91 ft/s)



IPA Classification: Report
 IG0704-400: ISO Class 1,
 according to standard DIN EN
 ISO 14644-1 for E3, Series E3-15-
 040-075-0 (at v = 1.64 ft/s, 3.28
 ft/s, 6.56 ft/s)



Special equipment: Electrically
 conductive ESD/ATEX version
 upon request

Assembly Tips

Rapid assembly time with interconnected
 crossbars

Usage Guidelines



- If a low noise, vibration-free version is required
- For very high speeds and/or accelerations (theoretically up to 100G or 3,281 ft/s (1000 m/s))
- Hard-wearing e-chain® (more than 50 million cycles with minimal abrasion)
- If a very light e-chain® is required (up to 40% lighter than comparable E2 e-chain®)
- For the use of flat cables
- For small bending radii and small spaces
- If easy filling and assembly is required
- Minimal abrasion (e.g. cleanroom applications)



- If a particularly low-cost snap-open solution is required
 ➤ **Series E06/Z06 E-Z Chain**
- If a simple, non snap-open e-chain® is required
 ➤ **Series 05 E2 micro**

Features & Benefits

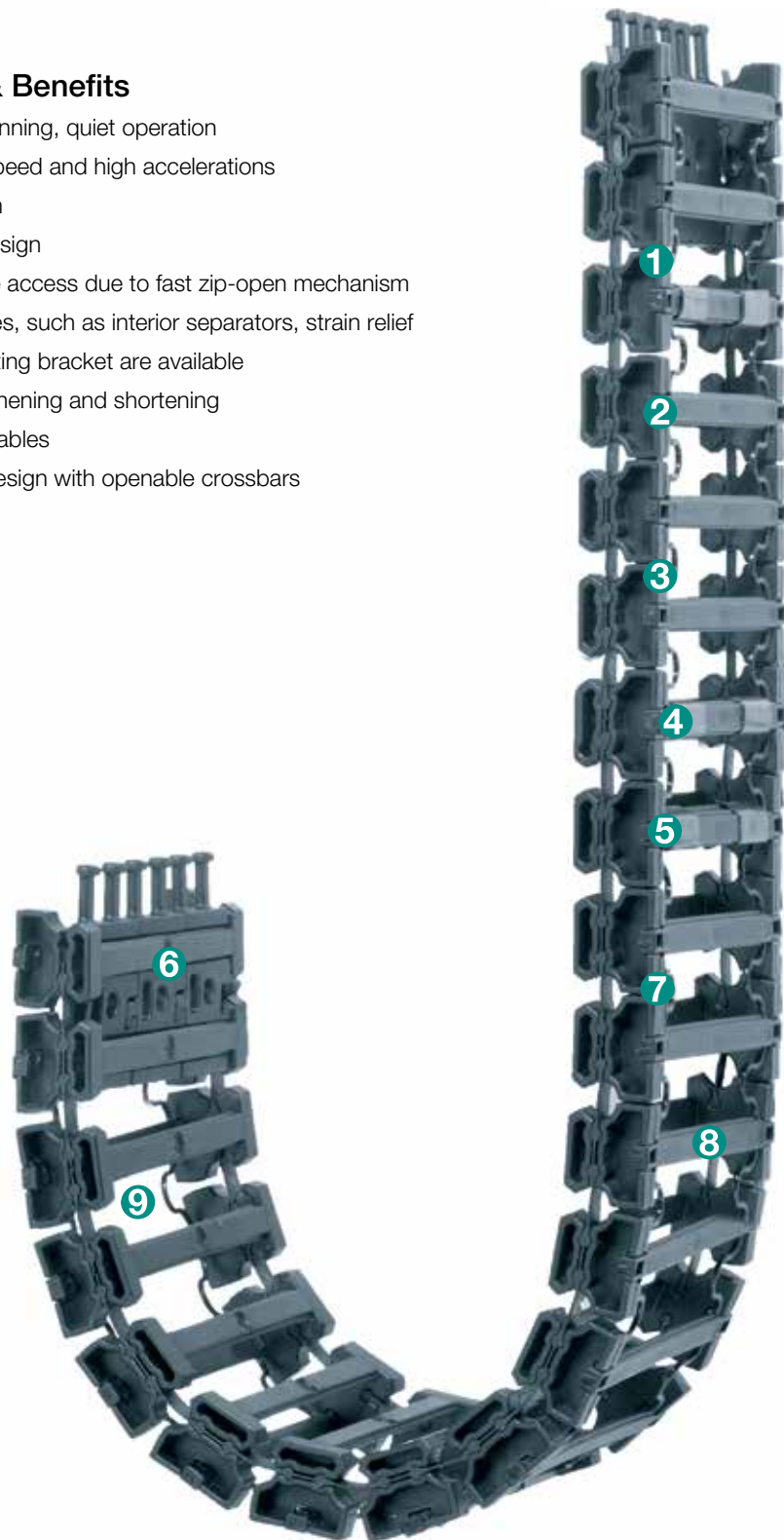
- 1 Smooth running, quiet operation
- 2 For high speed and high accelerations
- 3 Small pitch
- 4 3-piece design
- 5 Easy cable access due to fast zip-open mechanism
- 6 Accessories, such as interior separators, strain relief and mounting bracket are available
- 7 Easy lengthening and shortening
- 8 Suits flat cables
- 9 Modular design with openable crossbars

Order Example: Complete e-chain®

Please indicate chain length or number of links. Example:

3.28 ft (1 m) **E3-10-060-015-0**



e-chain®

With 2 separators **E3-10-11** assembled every 2nd link



Interior Separation

1 Set **E3-10-060-12**



Mounting Bracket

e-chain system® E3 Series E3-10



E3-10

Short travel, unsupported length

- FL_B = unsupported with permitted sag
 - FL_G = unsupported with straight upper run
- Further information ► Design, Chapter 1

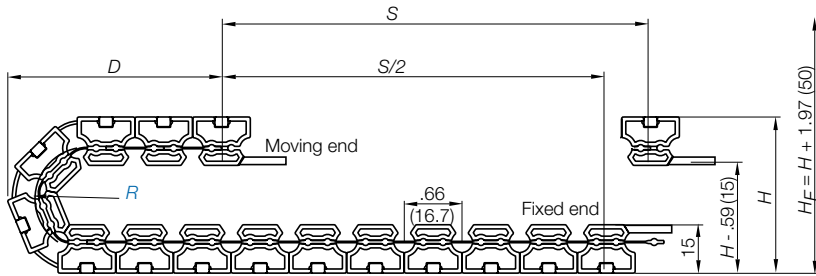
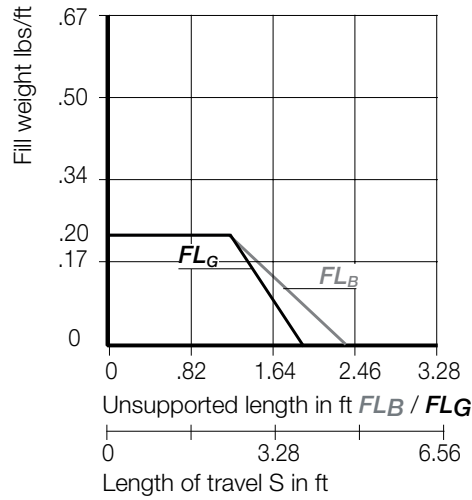
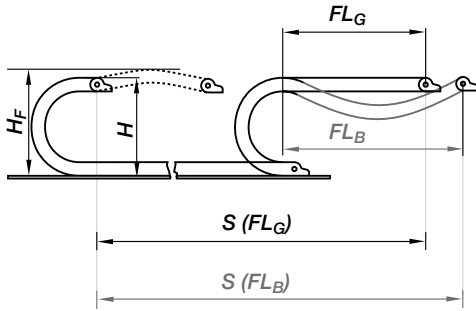

Pitch per link = $.66^\circ$ (16.7 mm)
 Links per ft (m) = 18.29 (60)
 For center mount applications:
 Chain length = $\frac{S}{2} + K$

The required clearance height: $H_F = H + 1.97$ in. (50 mm) (with 0.7 lbs/ft (0.1 kg/m) fill weight).
 Please consult igus® if space is particularly restricted.

R	.59 (015)	1.10 (028)	1.50 (038)	1.89 (048)
H	2.36 (60)	3.39 (86)	4.17 (106)	4.96 (126)
D	1.97 (50)	2.48 (63)	2.87 (73)	3.27 (83)
K	3.35 (85)	4.92 (125)	6.10 (155)	7.28 (185)

Short Travels - Unsupported



Unsupported e-chains® feature positive camber over short travels. This must be accounted for when specifying the clearance height. Please refer to **Installation dimensions** for further details.

Legend

- S = Length of travel
- R = Bending radius
- H = Nominal clearance height
- D = Overlength e-chain® radius in final position
- $K = \pi \cdot R + \text{safety buffer}$
- H_F = Required clearance height



PDF: igus.com/e-chain-pdfs
 Product information: igus.com/e-chains



Speed / acceleration FL_G	max. 65.6 ft/s (20 m/s) / max. 656 ft/s ² (200 m/s ²)
Speed / acceleration FL_B	max. 9.84 ft/s (3 m/s) / max. 19.69 ft/s ² (6 m/s ²)
Gliding speed / acceleration (maximum)	upon request
Permitted temperature	-40°F (-40°C) up to +158°F (+70° C)
Flammability Class	VDE 0304 IIC UL94 HB

Technical Data



Details of material properties

► Design, Chapter 1

Series E3-10 - Snap-open along the outer radius

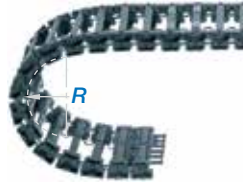
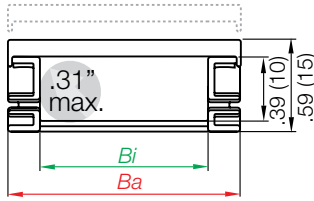

Part Number Structure

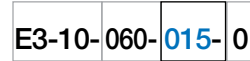

- Color - Black
- Bending radius
- Width
- Series

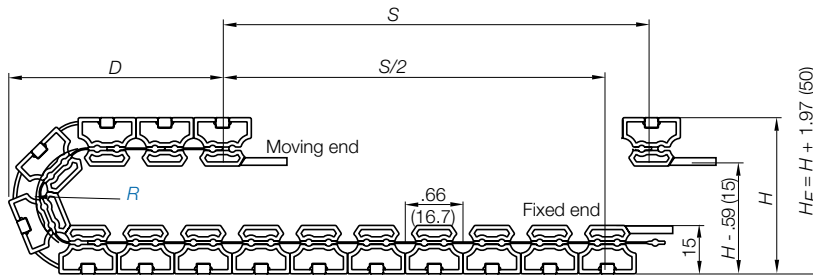

Supplement part number with required radius. Example: E3-10-060-015-0
Pitch: .66 in. (16.7 mm) per link links/ft (m) = 18.29 (60)

Part Number	Bi in. (mm)	Ba in. (mm)	Weight lbs/ft (kg/m)
E3-10-020- <input type="text"/> -0	.79 (20)	1.26 (32)	≈ 0.08 (0.12)
E3-10-040- <input type="text"/> -0	1.57 (40)	2.05 (52)	≈ 0.10 (0.15)
E3-10-060- <input type="text"/> -0	2.36 (60)	2.83 (72)	≈ 0.13 (0.20)

Choose from the radii below for all of the above sizes
Radius (mm) Example: E3-10-060-015-0

	015	028	038	048
R	.59 (015)	1.10 (028)	1.50 (038)	1.89 (048)
H	2.36 (60)	3.39 (86)	4.17 (106)	4.96 (126)
D	1.97 (50)	2.48 (63)	2.87 (73)	3.27 (83)
K	3.35 (85)	4.92 (125)	6.10 (155)	7.28 (185)

NOTE: E3-10-020-038, E3-10-020-048, E3-10-040-028, E3-10-060-028 and E3-10-060-048 are available upon request

Interior Separation

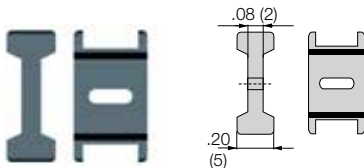

Separator, narrow head

Unassembled	Part No. E3-10-01
Assembled	Part No. E3-10-11

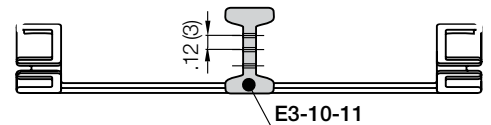

• Separator 45-2

Vertical separators are used if a vertical subdivision of the e-chain® interior is required.

e-chain system® E3
 Series E3-10
 KMA Mounting Bracket, Mounting Angle, Plastic



E3-10

Fixed end
 E3-10-...-2

Moving end
 E3-10-...-1

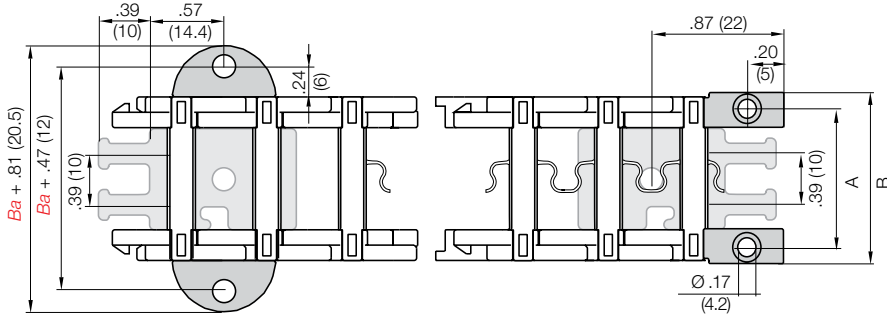

View Mounting angle

View KMA mounting bracket



E3-100-XXX-12 - Space-saving KMA mounting brackets

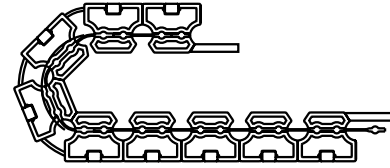

For Series	KMA Mounting bracket	Dimension A in. (mm)	Dimension B in. (mm)	Part No. Full Set strain relief both sides + 2 mounting angles	Part No. strain relief both sides	Part No. mounting angle* (single part)
E3-10-020	E3-100-020-12	1.10 (28)	1.42 (36)	E3-10-020-12	E3-020-12	E3-10-00
E3-10-040	E3-100-040-12	1.89 (48)	2.20 (56)	E3-10-040-12	E3-040-12	E3-10-00
E3-10-060	E3-100-060-12	2.68 (68)	2.99 (76)	E3-10-060-12	E3-060-12	E3-10-00

*Note: If the mounting brackets are used, two links each side must be added to the e-chain® length calculation, because the first to links are fixed by the mounting brackets.

E3-10-XXX-12



E3 with strain relief for both sides and mounting angles

E3-00-020



Strain relief for both sides as single parts

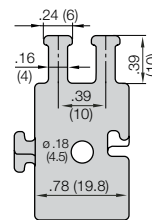

E3-10-00

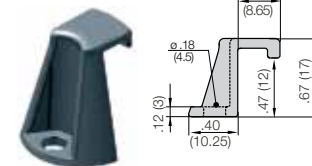

Mounting angle as single part

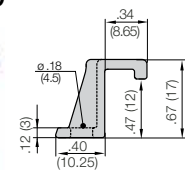

Full set, for both ends:

E3-10- [060- 12] Full set, both fixed and moving end

Single-part order:

E3-10 - [060- 1] Mounting bracket moving end

E3-10 - [060- 2] Mounting bracket fixed end

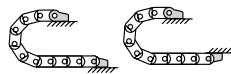

Possible installation configurations -

PDF: igus.com/e-chain-pdfs
 Product information: igus.com/e-chains



Price Index

Series E3-15
Special Features / Options

*Noise test values: max. 38dB(A)
 - Values determined at the igus®
 test lab according to DIN 45635
 (v = 5.91 ft/s)



IPA Classification: Report
 IG0704-400: ISO Class 1,
 according to standard DIN EN
 ISO 14644-1 for E3, Series E3-15-
 040-075-0 (at v = 1.64 ft/s, 3.28
 ft/s, 6.56 ft/s)



Special equipment: Electrically
 conductive ESD/ATEX version
 upon request

Assembly Tips

Rapid assembly time with interconnected
 crossbars

Usage Guidelines



- If a low noise, vibration-free version is required
- For very high speeds and/or accelerations (theoretically up to 100G or 3,281 ft/s (1000 m/s))
- Hard-wearing e-chain® (more than 50 million cycles with minimal abrasion)
- If a very light e-chain® is required (up to 40% lighter than comparable E2 e-chain®)
- For small bending radii and small spaces
- If easy filling and assembly is required
- Minimal abrasion (e.g. cleanroom applications)



- If a particularly low-cost snap-open solution is required
 ► **Series E08/Z08 E-Z Chain**
- If a simple, non snap-open e-chain® is required
 ► **Series 08 E2 Micro**

Features & Benefits

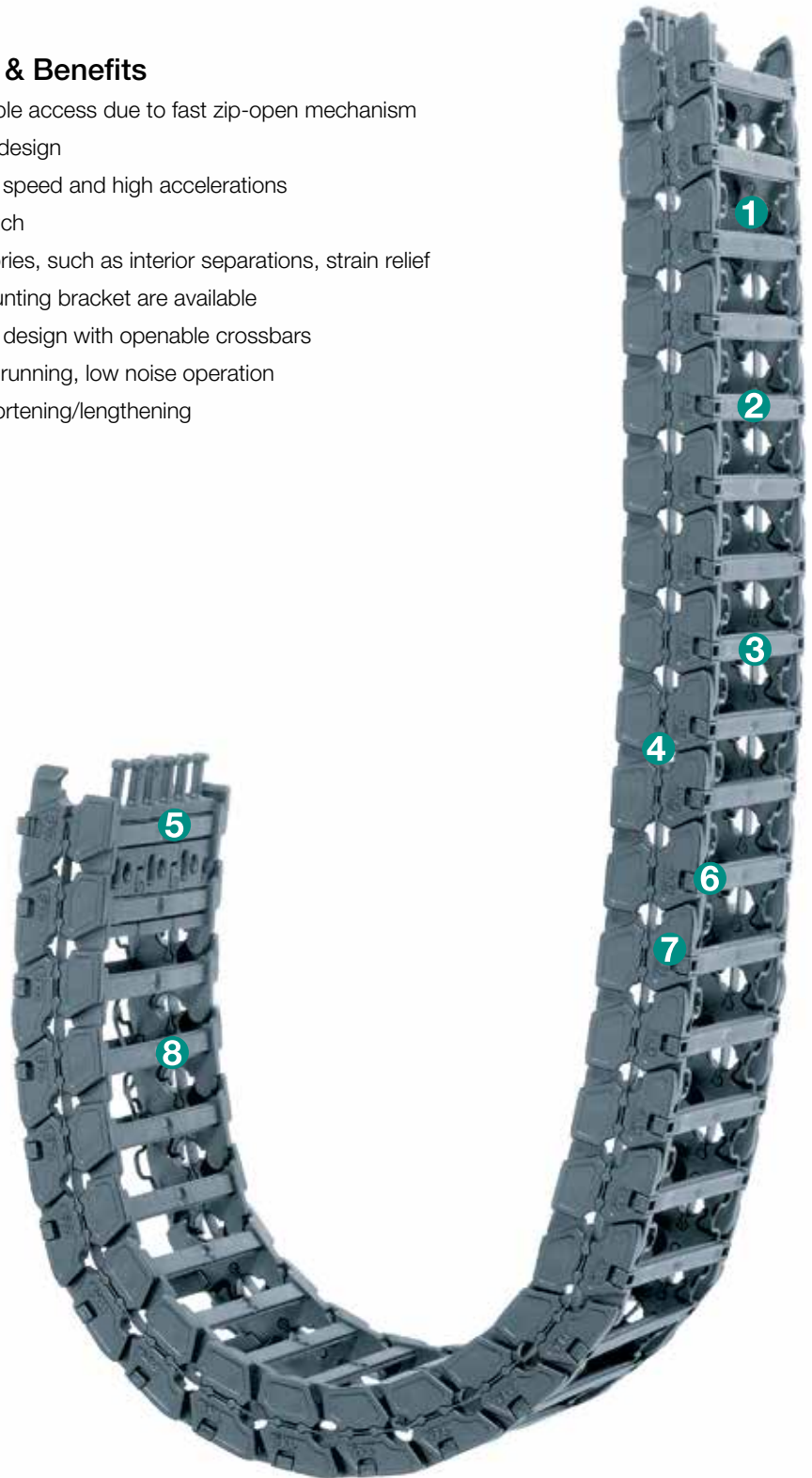
- 1 Easy cable access due to fast zip-open mechanism
- 2 3-piece design
- 3 For high speed and high accelerations
- 4 Small pitch
- 5 Accessories, such as interior separations, strain relief and mounting bracket are available
- 6 Modular design with openable crossbars
- 7 Smooth running, low noise operation
- 8 Easy shortening/lengthening

Order Example: Complete e-chain®

Please indicate chain length or number of links. Example:

3.28 ft (1 m) **E3-15-060-032-0**



e-chain®

With 2 separators **E3-15-11** assembled every 2nd link



Interior Separation

1 Set **E3-15-060-12**



Mounting Bracket

e-chain system® E3 Series E3-15



E3-15

Short travel, unsupported length

- FL_B = unsupported with permitted sag
 - FL_G = unsupported with straight upper run
- Further information ► Design, Chapter 1

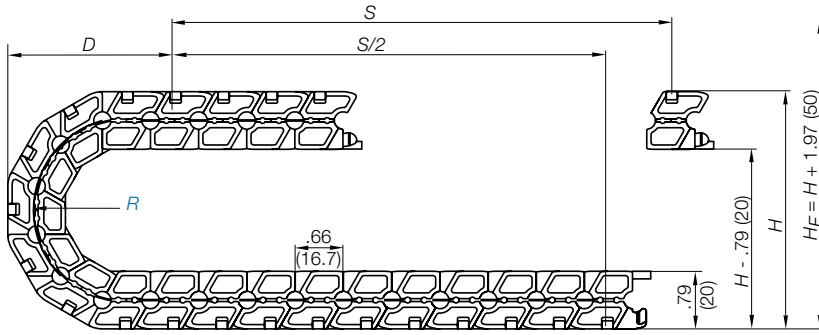
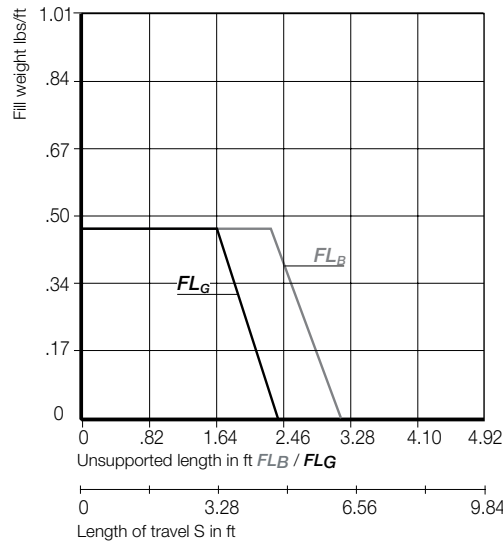
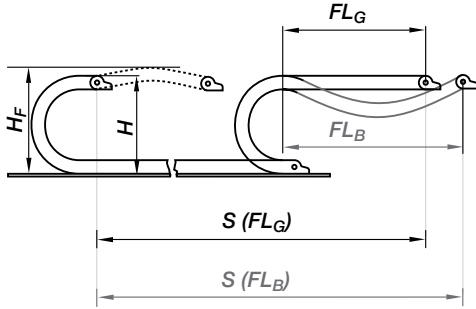

Pitch per link = .66" (16.7 mm)
 Links per ft (m) = 18.29 (60)
 For center mount applications:
 Chain length = $S/2 + K$

The required clearance height: $H_F = H + 1.97$ in. (50 mm) (with 0.13 lbs/ft (0.2 kg/m) fill weight).
 Please consult igus® if space is particularly restricted.

R	1.26 (032)	1.50 (038)	1.89 (048)	2.95 (075)
H	3.90 (99)	4.37 (111)	5.16 (131)	7.28 (185)
D	2.64 (67)	2.87 (73)	3.27 (83)	4.33 (110)
K	5.31 (135)	6.10 (155)	7.28 (185)	10.63 (270)

Short Travels - Unsupported



Unsupported e-chains® feature positive camber over short travels. This must be accounted for when specifying the clearance height. Please refer to **Installation dimensions** for further details.

Legend

- S = Length of travel
- R = Bending radius
- H = Nominal clearance height
- D = Overlength e-chain® radius in final position
- $K = \pi \cdot R + \text{safety buffer}$
- H_F = Required clearance height



PDF: igus.com/e-chain-pdfs
 Product information: igus.com/e-chains



Speed / acceleration FL_G	max. 65.6 ft/s (20 m/s) / max. 656 ft/s ² (200 m/s ²)
Speed / acceleration FL_B	max. 9.84 ft/s (3 m/s) / max. 19.69 ft/s ² (6 m/s ²)
Gliding speed / acceleration (maximum)	upon request
Permitted temperature	-40°F (-40°C) up to +158°F (+70° C)
Flammability Class	VDE 0304 IIC UL94 HB

Technical Data



Details of material properties

► Design, Chapter 1

Series E3-15 - Snap-open along the outer radius

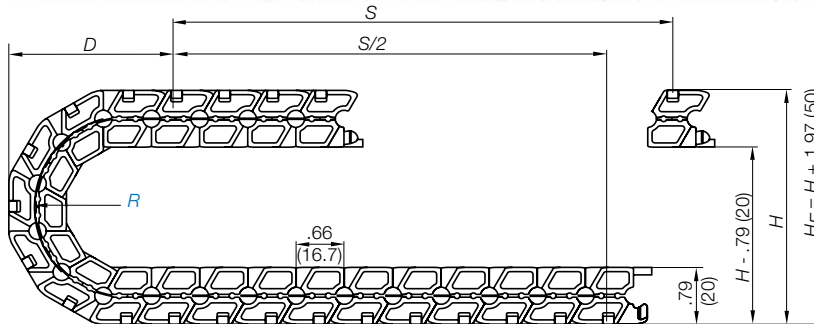
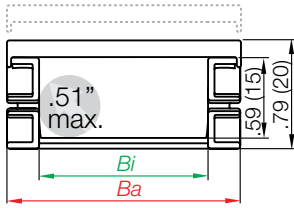

Part Number Structure

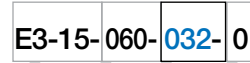

- Color - Black
- Bending radius
- Width
- Series

Supplement part number with required radius. Example: E3-15-060-032-0
Pitch: .66 in. (16.7 mm) per link links/ft (m) = 18.29 (60)

Part Number	Bi in. (mm)	Ba in. (mm)	Weight lbs/ft (kg/m)
E3-15-020- <input type="text"/> -0*	.79 (20)	1.26 (32)	≈ 0.15 (0.22)
E3-15-040- <input type="text"/> -0	1.57 (40)	2.05 (52)	≈ 0.17 (0.25)
E3-15-060- <input type="text"/> -0	2.36 (60)	2.83 (72)	≈ 0.22 (0.32)

Choose from the radii below for all of the above sizes

Radius (mm) Example: E3-15-060-032-0

	032	038	048	075
R	1.26 (032)	1.50 (038)	1.89 (048)	2.95 (075)
H	3.90 (99)	4.37 (111)	5.16 (131)	7.28 (185)
D	2.64 (67)	2.87 (73)	3.27 (83)	4.33 (110)
K	5.31 (135)	6.10 (155)	7.28 (185)	10.63 (270)

*Radii 038 and 075 are not available for the E3-15-020
NOTE: E3-15-020-048 is available upon request

Interior Separation

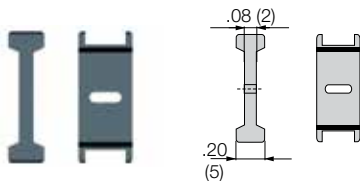
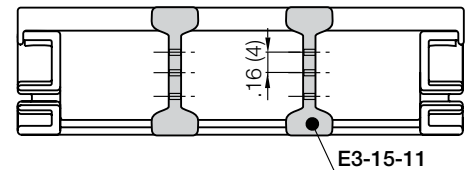

Slotted separator for e-chains®

Unassembled	Part No. E3-15-01
Assembled	Part No. E3-15-11



Separator, narrow base

Unassembled	Part No. E3-15-01-10
Assembled	Part No. E3-15-11-10

- **Separator E3-15-01**
Vertical separators are used if a vertical subdivision of the e-chain® interior is required.

- **Slotted separator on a strip E3-15-01-10**
Five vertical separators connected on one strip span ten e-chain® links and are mounted on the opening crossbars. This creates separate chambers, protecting the cables. The dimensions are the same as the E3-22-01 slotted separator

e-chain® E3
 Series E3-15
 KMA Mounting Bracket, Mounting Angle, Plastic



E3-15

Fixed end
 E3-15-...-2

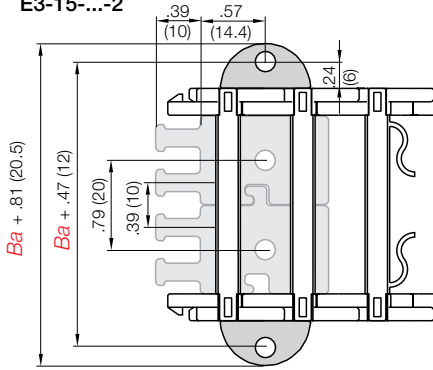

View Mounting angle

Moving end
 E3-15-...-1

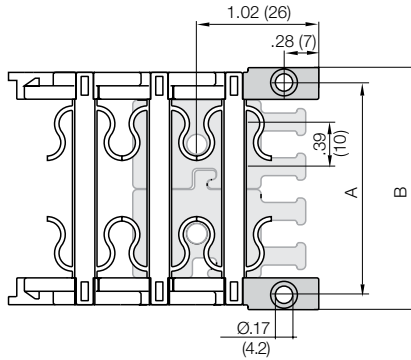

View KMA mounting bracket



E3-150-XXX-12 - Space-saving KMA mounting brackets

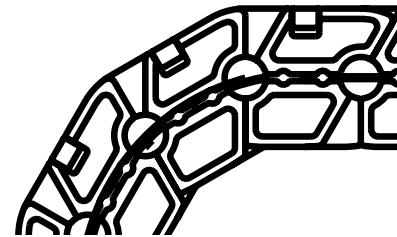

For Series	KMA Mounting bracket	Dimension A in. (mm)	Dimension B in. (mm)	Part No. Full Set strain relief both sides + 2 mounting angles	Part No. strain relief both sides	Part No. mounting angle* (single part)
E3-15-020	E3-150-020-12	.10 (28)	1.42 (36)	E3-15-020-12	E3-020-12	E3-15-00
E3-15-040	E3-150-040-12	1.89 (48)	2.20 (56)	E3-15-040-12	E3-040-12	E3-15-00
E3-15-060	E3-150-060-12	2.68 (68)	2.99 (76)	E3-15-060-12	E3-060-12	E3-15-00

*Note: If the mounting brackets are used, two links each side must be added to the e-chain® length calculation, because the first to links are fixed by the mounting brackets.

E3-15-XXX-12



E3 with strain relief for both sides and mounting angles

E3-00-020



Strain relief for both sides as single parts

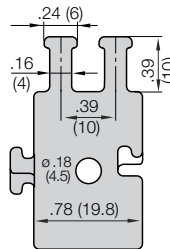

E3-15-00



Mounting angle as single part

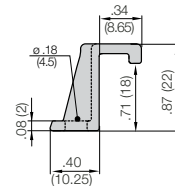

Full set, for both ends:

E3-15- 020- 12 Full set, both fixed and moving end

Single-part order:

E3-15 - 020- 1 Mounting bracket moving end

E3-15 - 020- 2 Mounting bracket fixed end

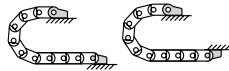

Possible installation configurations -

PDF: igus.com/e-chain-pdfs
 Product information: igus.com/e-chains



Price Index

Series E3-22
Special Features / Options

*Noise test values: max. 38dB(A)
 - Values determined at the igus®
 test lab according to DIN 45635
 (v = 5.91 ft/s)



IPA Classification: Report
 IG0704-400: ISO Class 1,
 according to standard DIN EN
 ISO 14644-1 for E3, Series E3-15-
 040-075-0 (at v = 1.64 ft/s, 3.28
 ft/s, 6.56 ft/s)



Special equipment: Electrically
 conductive ESD/ATEX version
 upon request

Assembly Tips

Rapid assembly time with interconnected
 crossbars

Usage Guidelines



- If a low noise, vibration-free version is required
- For very high speeds and/or accelerations (theoretically up to 100G or 3,281 ft/s (1000 m/s))
- Hard-wearing e-chain® (more than 50 million cycles with minimal abrasion)
- If a very light e-chain® is required (up to 40% lighter than comparable E2 e-chain®)
- For small bending radii and small spaces
- If easy filling and assembly is required
- Minimal abrasion (e.g. cleanroom applications)



- If a particularly low-cost snap-open solution is required
 ➤ **Series E14/Z14 E-Z Chain**
- If a simple, non snap-open e-chain® is required
 ➤ **Series 1400/1450/1500 E2 Medium**

Features & Benefits

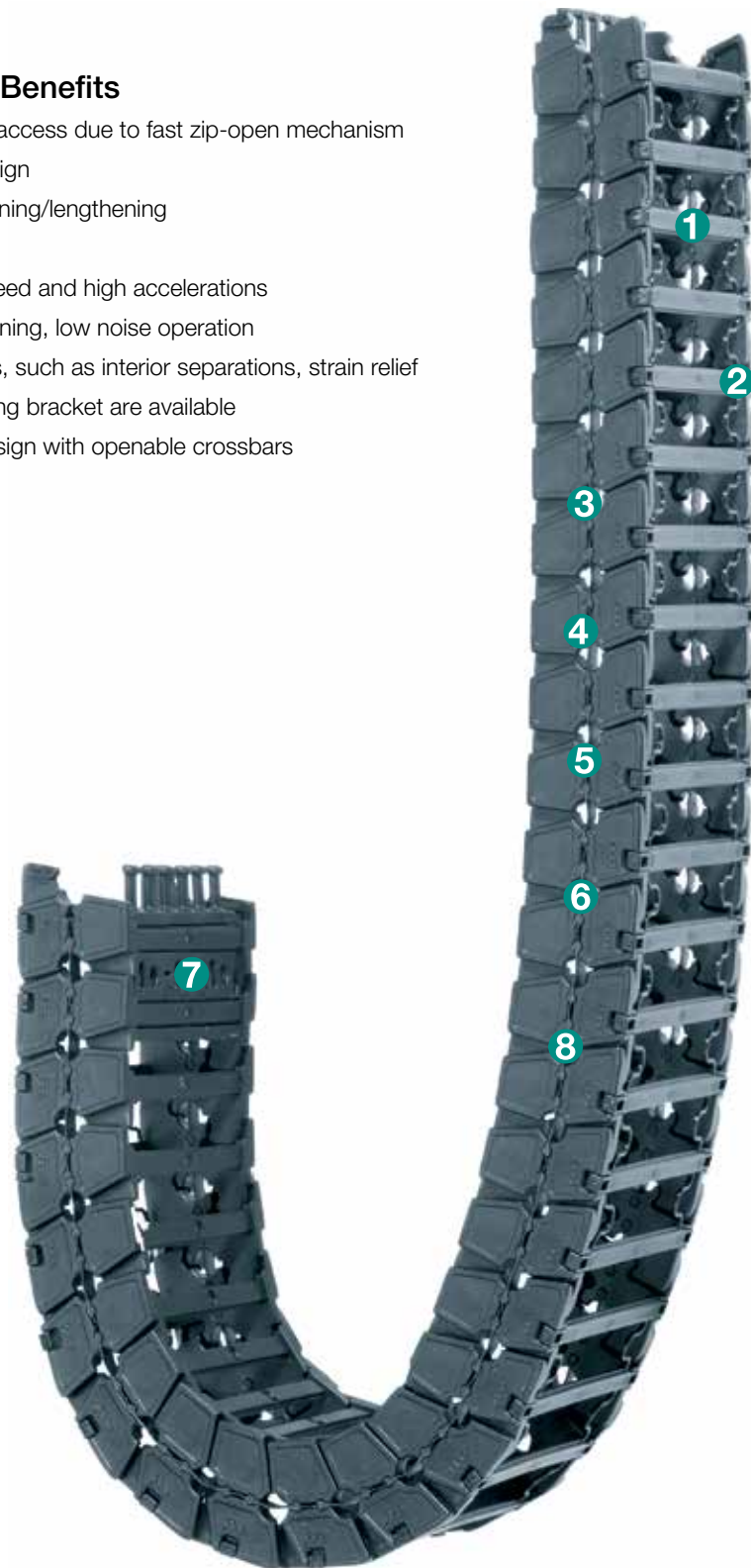
- 1 Easy cable access due to fast zip-open mechanism
- 2 3-piece design
- 3 Easy shortening/lengthening
- 4 Small pitch
- 5 For high speed and high accelerations
- 5 Smooth running, low noise operation
- 7 Accessories, such as interior separations, strain relief and mounting bracket are available
- 8 Modular design with openable crossbars

Order Example: Complete e-chain®

Please indicate chain length or number of links. Example:

3.28 ft (1 m) **E3-22-060-044-0**



e-chain®

With 2 separators **E2-22-11** assembled every 2nd link



Interior Separation

1 Set **E3-22-060-12**



Mounting Bracket

Short travel, unsupported length

- FL_B = unsupported with permitted sag
 - FL_G = unsupported with straight upper run
- Further information ► Design, Chapter 1

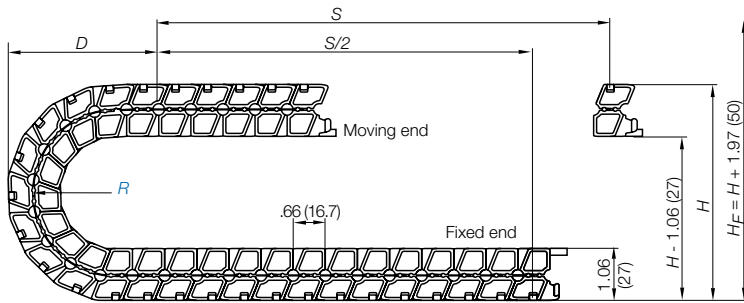
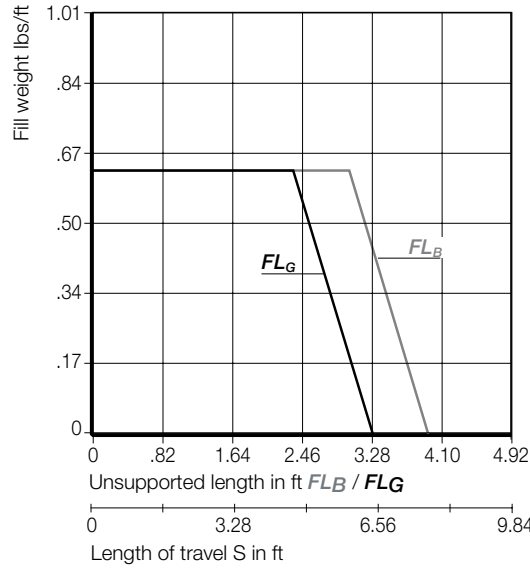
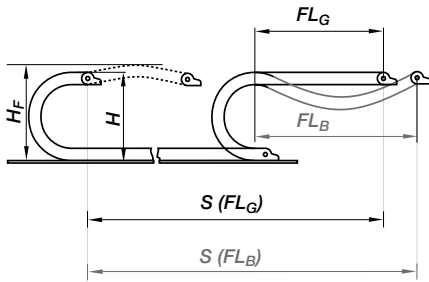

The required clearance height: $H_F = H + 1.97$ in. (50 mm) (with 0.20 lbs/ft (0.3 kg/m) fill weight). Please consult igus® if space is particularly restricted.

R	1.73 (044)	1.97 (050)	2.95 (075)
H	5.28 (134)	5.75 (146)	6.93 (176)
D	3.23 (82)	3.15 (80)	4.13 (105)
K	6.89 (175)	7.68 (195)	10.63 (270)

Short Travels - Unsupported



Unsupported e-chains® feature positive camber over short travels. This must be accounted for when specifying the clearance height. Please refer to **Installation dimensions** for further details.

Legend

- S = Length of travel
- R = Bending radius
- H = Nominal clearance height
- D = Overlength e-chain® radius in final position
- $K = \pi \cdot R + \text{safety buffer}$
- H_F = Required clearance height

Pitch per link = $.66^\circ$ (16.7 mm)
Links per ft (m) = 18.29 (60)
For center mount applications:
Chain length = $\frac{S}{2} + K$

Speed / acceleration FL_G	max. 65.6 ft/s (20 m/s) / max. 656 ft/s ² (200 m/s ²)
Speed / acceleration FL_B	max. 9.84 ft/s (3 m/s) / max. 19.69 ft/s ² (6 m/s ²)
Gliding speed / acceleration (maximum)	upon request
Permitted temperature	-40°F (-40°C) up to +158°F (+70° C)
Flammability Class	VDE 0304 IIC UL94 HB

Technical Data



Details of material properties

► Design, Chapter 1



Series E3-22 - Snap-open along the outer radius

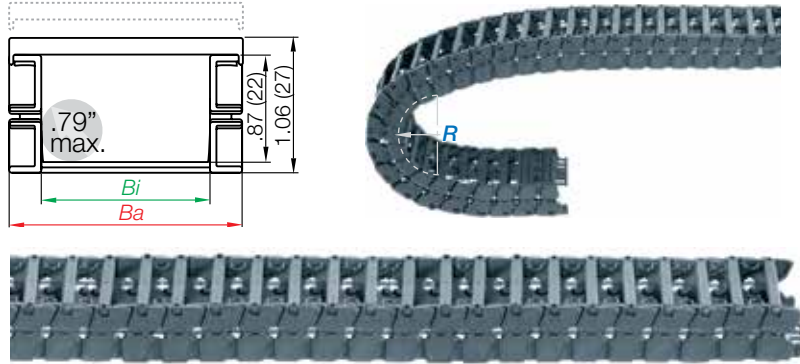

Part Number Structure

E3-22-060-044-0

- Color - Black
- Bending radius
- Width
- Series

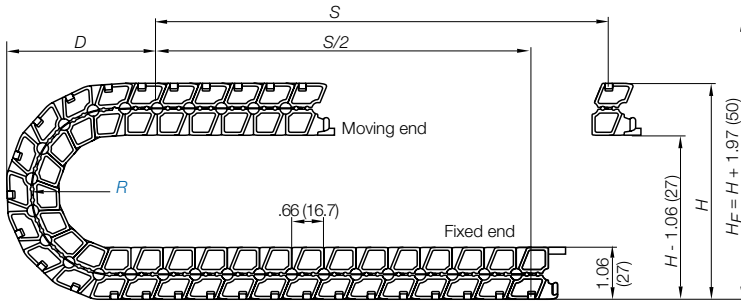

Supplement part number with required radius. Example: E3-22-060-044-0
 Pitch: .66 in. (16.7 mm) per link links/ft (m) = 18.29 (60)

Part Number	Bi in. (mm)	Ba in. (mm)	Weight lbs/ft (kg/m)
E3-22-020- <input type="text"/> -0	.79 (20)	1.26 (32)	≈ 0.20 (0.30)
E3-22-040- <input type="text"/> -0	1.57 (40)	2.05 (52)	≈ 0.22 (0.32)
E3-22-060- <input type="text"/> -0	2.36 (60)	2.83 (72)	≈ 0.28 (0.41)

Choose from the radii below for all of the above sizes
 Radius (mm) Example: E3-22-060-044-0

	044	050*	075
R	1.73 (044)	1.97 (050)	2.95 (075)
H	5.28 (134)	5.75 (146)	6.93 (176)
D	3.23 (82)	3.15 (80)	4.13 (105)
K	6.89 (175)	7.68 (195)	10.63 (270)

* Radius 050 is not available for the E3-22-060

Interior Separation

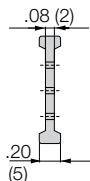
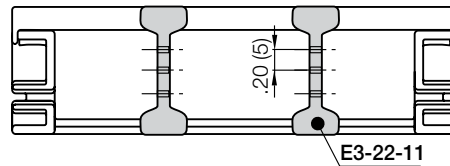

Slotted separator for e-chains®
 Unassembled Part No. E3-22-01
 Assembled Part No. E3-22-11

- Slotted separator E3-22-01
 Vertical separators are used if a vertical subdivision of the e-chain® interior is required.

Fixed end
E3-22-...-2

Moving end
E3-22-...-1

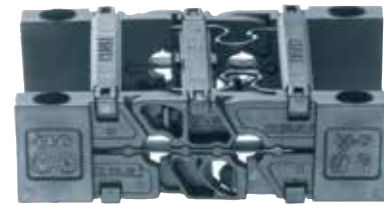
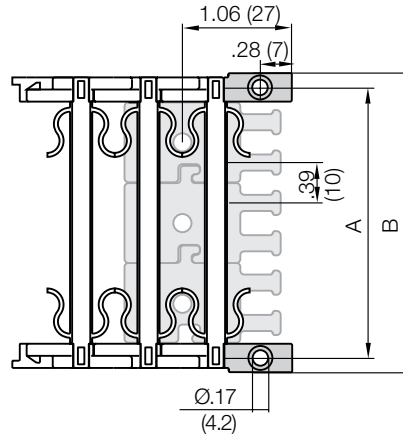
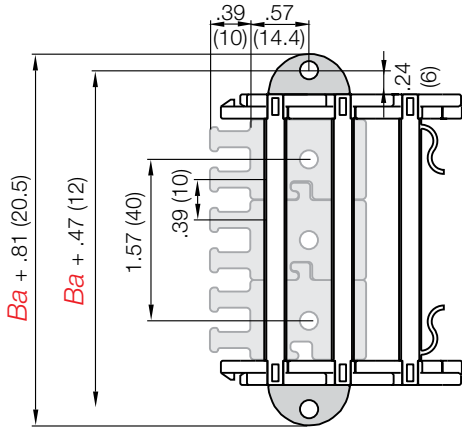

E3-220-XXX-12 - Space-saving KMA mounting brackets

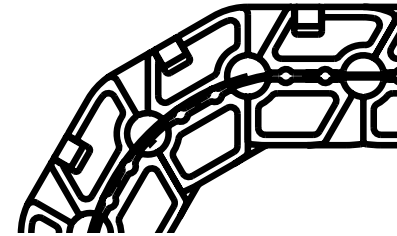

View mounting angle

View KMA mounting bracket

For Series	KMA Mounting bracket	Dimension A in. (mm)	Dimension B in. (mm)	Part No. Full Set strain relief both sides + 2 mounting angles	Part No. strain relief both sides	Part No. mounting angle (single part)
E3-22-020	E3-220-020-12	.10 (28)	1.42 (36)	E3-22-020-12	E3-020-12	E3-22-00
E3-22-040	E3-220-040-12	1.89 (48)	2.20 (56)	E3-22-040-12	E3-040-12	E3-22-00
E3-22-060	E3-220-060-12	2.68 (68)	2.99 (76)	E3-22-060-12	E3-060-12	E3-22-00

*Note: If the mounting brackets are used, two links each side must be added to the e-chain[®] length calculation, because the first to links are fixed by the mounting brackets.

E3-22-XXX-12



E3 with strain relief for both sides and mounting angles

E3-00-020



Strain relief for both sides as single parts

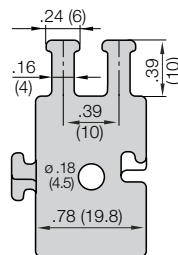

E3-22-00



Mounting angle as single part

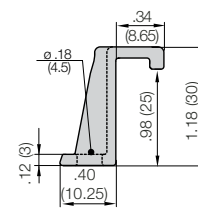

Full set, for both ends:

E3-22- 060- 12 Full set, both fixed and moving end

Single-part order:

E3-22- 060- 1 Mounting bracket moving end

E3-22- 060- 2 Mounting bracket fixed end

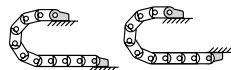

Possible installation configurations -







igus[®] System E6-1

More dynamics, smoother running, easier to open, 2nd generation

The E6-1 series is an advancement of the E6 series. While having all its advantages, like the stability and cleanroom suitability, it is even lighter, faster and quieter. In addition, its accessibility to the interior and the assembly and handling have been improved.

- Crossbars can be opened on both sides and removable along the inner and outer radius
- Option without camber NC by turning the inner link
- Extremely quiet through small pitch and brake in the stop-dog system
- Extremely low vibration
- Low-abrasion link system (no pin/hole connection)
- Virtually no polygon effect, thereby “smooth rolling” operation
- Faster lengthening and shortening through optimized connection design
- Smooth and obstacle free interior design for a long lifetime for cables and hoses
- Weight savings approx. 30% compared to the System E6
- Cost-effective



System E6-1
Extremely low noise



System E6
6-piece link-design



IPA Qualification Certificate - Report IG 1303-640-1:
ISO Class 1, according to DIN EN ISO 14644-1 for System E6-1,
Series E61-29-50-075-0 and E61-29-50-075-0-CR
at $v = 1.64 \text{ ft/s (0.5 m/s), 3.28 ft/s (1 m/s), 6.56 ft/s (2 m/s)}$



e-chain system® E6-1

Selection Table

Series	Inner height h_i		Inner width B_i		Outer width B_a		Outer height h_a		Bend radius R		Unsupported length	
	in.	(mm)	in.	(mm)	in.	(mm)	in.	(mm)	in.	(mm)	≤ ft.	≤ (m)



E6-1 e-chains®
openable along inner and outer radius, from both sides

E61-29	1.14	(29)	1.18-5.51	(30-140)	1.73-6.06	(44-154)	1.38	(35)	2.17-5.91	(055-150)	5.74	(≈ 1.75)
--------	------	------	-----------	----------	-----------	----------	------	------	-----------	-----------	------	----------



E6-1 e-chains®
crossbars removable along the inner and outer radius

EF61-29	1.14	(29)	1.18-5.51	(30-140)	1.73-6.06	(44-154)	1.38	(35)	2.17-5.91	(055-150)	5.74	(≈ 1.75)
E61-35	1.38	(35)	1.18-5.51	(30-140)	1.81-6.14	(46-156)	1.65	(42)	2.17-5.91	(055-150)	6.23	(≈ 1.90)
E61-40	1.57	(40)	1.57-11.81	(40-300)	2.20-12.44	(56-316)	2.13	(54)	2.48-7.87	(063-200)	8.20	(≈ 2.50)
E61-52	2.05	(52)	1.57-11.81	(40-300)	2.52-12.76	(64-324)	2.56	(65)	2.95-5.91	(075-150)	9.84	(≈ 3.00)
E61-62	2.44	(62)	1.97-15.75	(50-400)	3.22-17.01	(82-432)	3.31	(84)	4.53	(115)	13.12	(≈ 4.00)
E61-80	3.15	(80)	1.97-15.75	(50-600)	3.07-24.72	(78-628)	4.25	(108)	5.91	(150)	17.23	(≈ 5.25)



Available from stock. Orders ship as early as today.*

*On average 90% of orders ship the same day..

Cost-effective - Series EF61-29

- Series EF61-29 - 1.14" (29mm) inner height
- Available at an even lower price without the pivoting function of the crossbars
- Crossbars removable from both sides
- Otherwise, technically the same as the E61-29 series.

More information ► www.igus.com



e-chain system® E6-1

Features - Accessories



New generation interior separation - even more cable-friendly



Snap-open mechanism, Series E61-29 choice of snap-open on left or right

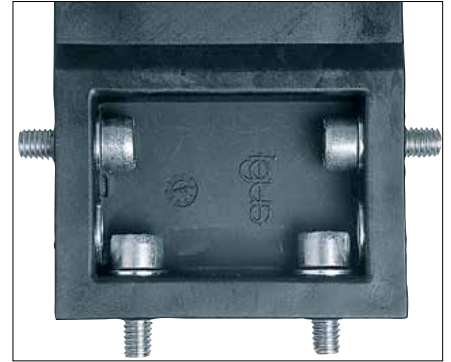

KMA mounting brackets with attachment options on all sides

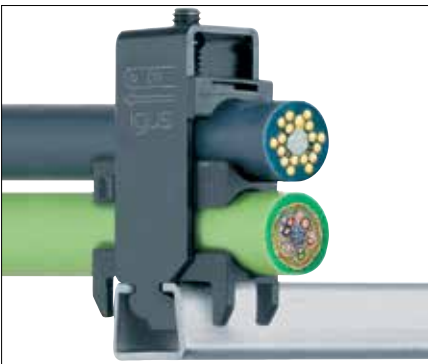

Strain relief clamps, tiwrap plates, nuggets and plug-in clips ▶ **Section 10**



Pivoting and locking KMA mounting brackets are available



Support tray tool kit. For support of the lower run ▶ **Section 9**

E6-1 for cleanrooms

Cleanroom qualification of E6-1 e-chains®

By using a special material, the already low abrasion of the e-chain® can be reduced even further. In many applications where cumbersome special solutions are required, a simple standard e-chain® can be used instead. IPA tests confirm that standard igus® e-chains® meet cleanroom requirements. "Tested and certified as very good!" e-chains® for cleanroom applications demand very high wear resistance of moving parts in order to meet the normal requirements for such a sensitive environment.



IPA Qualification Certificate²⁾ - Report IG 1303-640-1:
 ISO Class 1, according to DIN EN ISO 14644-1 for system E6-1, series E61-29-50-075-0 and E61-29-50-075-0-CR at v = 0.5m/s, 1m/s, 2m/s

e-chain system® E6-1 Advantages



The fact that the interior of the new E6-1 has been designed to be extremely cable-friendly underlines its suitability for cleanrooms by increasing the service life of cables and hoses even more. The crossbars are very smooth and rounded as is the transition from e-chain® link to crossbar, and all markings have been moved outside of the e-chain® cross section.

System E6-1 internal tests in the igus® lab

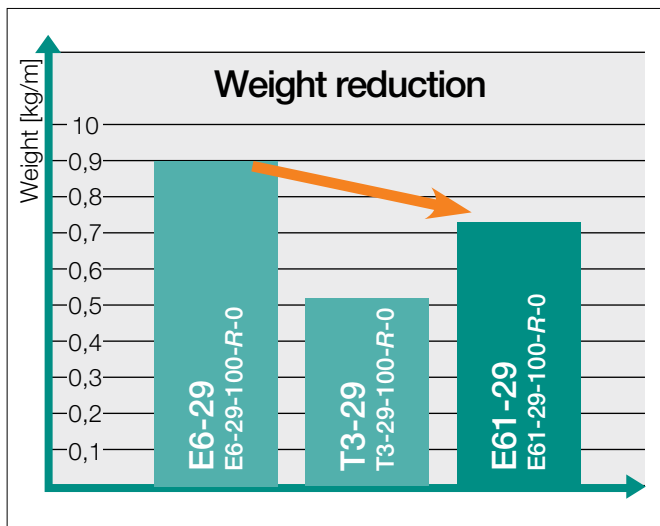

The E6-1 generation can take up higher accelerations, due to a weight reduction, making it a highly dynamic yet still extremely quiet e-chain®

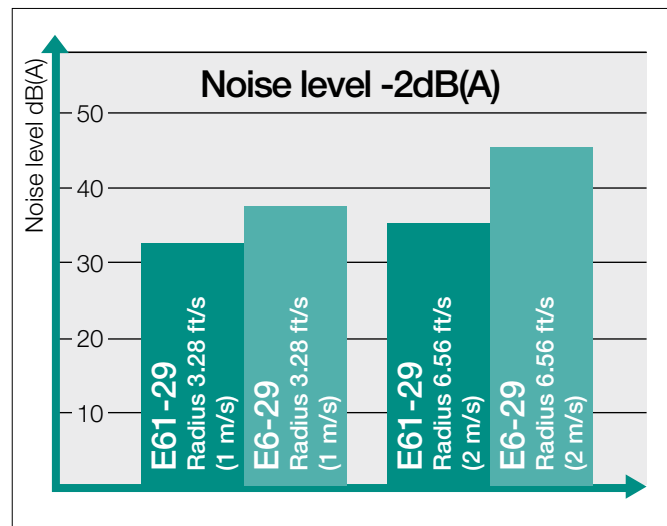

Series E61-29 tests in the igus® test lab show noise levels, which are 2 dB(A) below the already class-leading noise-levels of the igus® E6-29 series

Price Index



Series E61-29

Special Features / Options



Extremely low noise
Test results upon request



IPA Certificate: Class 1, according to standard DIN EN ISO 14644-1 for the E6 system (Series E6-29-060-150-0-CR, (v = 1.64 ft/s, a = 3.28 ft/s²))

Assembly Tips



snap-open mechanism

Other Installation Methods

Vertical, hanging ≤ 82 ft (25 m)

Vertical, standing ≤ 6.56 ft (2 m)

Side-mounted, unsupported = upon request

Unsupported length of upper run ≤ 11.48 ft (3.5 m)

Usage Guidelines



- If a low-noise version is required
- For very high speeds and/or accelerations
- If large stresses and thrust forces are present
- For small bending radii
- If less vibration is required
- Minimal abrasion, suitable for cleanrooms



- For side-mounted applications
➤ Series E2/000
- For RBR (reverse bending radii)
➤ Series E2/000
- For high additional loads
➤ Series E2/000
- For very dirty environments
➤ Series R6

Features & Benefits

- 1 KMA mounting brackets with attachment points on all sides
- 2 Small pitch for low-noise, smooth operation
- 3 Crossbars open on either side
- 4 For high speed and high accelerations
- 5 Minimum vibration, high stability and tensile strength
- 6 No pin and bore connection - polymer spring



Order Example: Complete e-chain®

Please indicate chain length or number of links. Example:

3.28 ft (1 m) E61-29-100-075-0



e-chain®

With 2 separators 29-1-1 assembled every 2nd link



Interior Separation

1 Set E61-290-100-12



Mounting Bracket

e-chain system® E6-1

Series EF61-29 / E61-29

Installation Dimensions



EF61-29
E61-29

Short travel, unsupported length

- FL_B = unsupported with permitted sag
 - FL_G = unsupported with straight upper run
- Further information ► Design, Chapter 1

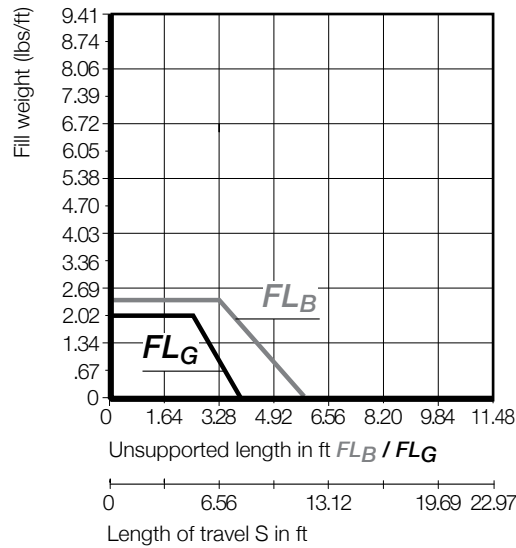
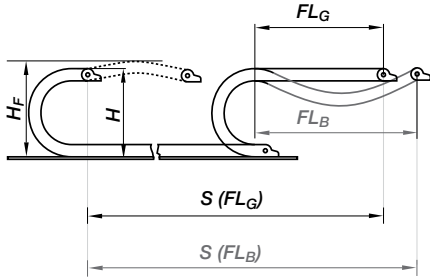

Short Travels - Unsupported

Unsuported e-chains® feature positive camber over short travels. This must be accounted for when specifying the clearance height. Please refer to **Installation dimensions** for further details.

Legend

- S = Length of travel
- R = Bending radius
- H = Nominal clearance height
- D = Overlength e-chain® radius in final position
- $K = \pi \cdot R + \text{safety buffer}$
- H_F = Required clearance height

1.14

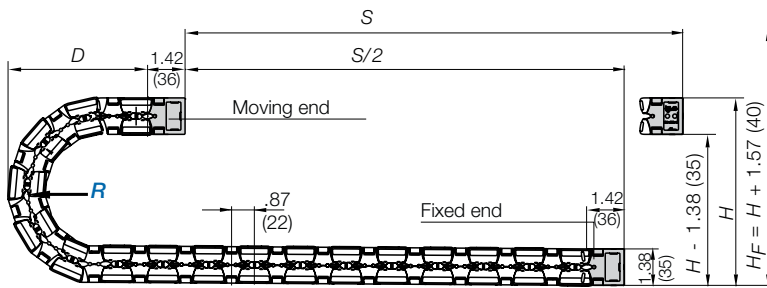

Pitch per link = .87" (22 mm)
 Links per ft (m) = 13.79 (46)
 For center mount applications:
 Chain length = $S/2 + K$

The required clearance height: $H_F = H + 1.57$ in. (40 mm) (with 1.34 lbs/ft (2.0 kg/m) fill weight). Please consult igus® if space is particularly restricted.

R	2.17 (055)	2.95 (075)	3.94 (100)	4.92 (125)	5.91 (150)
H	6.89 (175)	8.46 (215)	10.43 (265)	12.40 (315)	14.37 (365)
D	4.15 (105.5)	4.94 (125.5)	5.93 (150.5)	6.91 (175.5)	7.89 (200.5)
K	8.66 (220)	11.02 (280)	14.17 (360)	17.32 (440)	20.47 (520)

Speed / acceleration FL_G	max. 65.6 ft/s (20 m/s) / max. 656 ft/s ² (200 m/s ²)
Speed / acceleration FL_B	max. 9.84 ft/s (3 m/s) / max. 19.69 ft/s ² (6 m/s ²)
Gliding speed / acceleration (maximum)	upon request
Permitted temperature, igumid G	upon request
Flammability Class	VDE 0304 IIC UL94 HB

Technical Data



Details of material properties

► Design, Chapter 1

PDF: igus.com/e-chain-pdfs
 Product information: igus.com/e-chains



Series EF61-29 - e-chain® - crossbars removable along the inner and outer radius
 Series E61-29 - e-chain® - crossbars openable along the inner and outer radius, from both sides

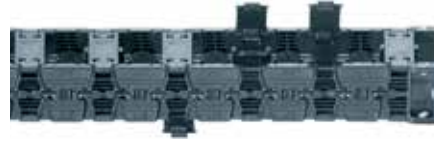
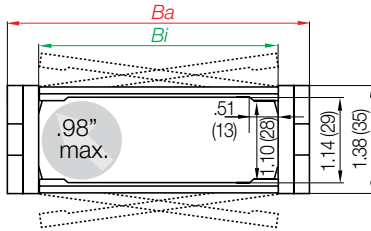

Part Number Structure

E61-29-100-100-0

- Color - Black
- Bending radius
- Width
- Series

Telephone 1-800-521-2747

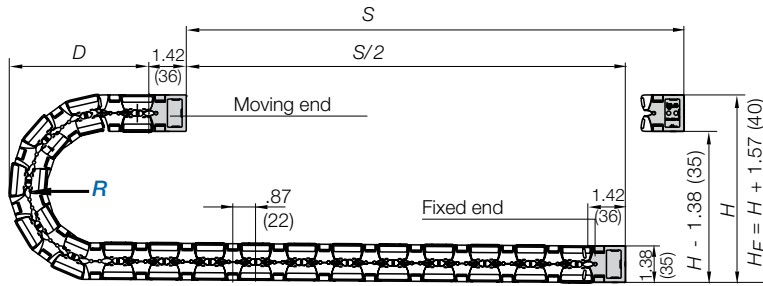

Supplement part number with required radius. Example: E61-29-100-100-0
 Pitch: .87 in. (22 mm) per link links/ft (m) = 13.79 (46)

Part Number removable crossbars	Part Number openable from both sides	Bi in. (mm)	Ba in. (mm)	Weight lbs/ft (kg/m)
EF61-29-030-0	E61-29-030-0	1.18 (30)	1.73 (44)	≈ 0.37 (0.558)
EF61-29-040-0	E61-29-040-0	1.57 (40)	2.13 (54)	≈ 0.39 (0.583)
EF61-29-050-0	E61-29-050-0	1.97 (50)	2.52 (64)	≈ 0.41 (0.608)
EF61-29-060-0	E61-29-060-0	2.36 (60)	2.91 (74)	≈ 0.43 (0.633)
EF61-29-070-0	E61-29-070-0	2.76 (70)	3.31 (84)	≈ 0.44 (0.657)
EF61-29-080-0	E61-29-080-0	3.15 (80)	3.70 (94)	≈ 0.46 (0.682)
EF61-29-090-0	E61-29-090-0	3.54 (90)	4.09 (104)	≈ 0.48 (0.707)
EF61-29-100-0	E61-29-100-0	3.94 (100)	4.49 (114)	≈ 0.49 (0.732)
EF61-29-110-0	E61-29-110-0	4.33 (110)	4.88 (124)	≈ 0.51 (0.757)
EF61-29-120-0	E61-29-120-0	4.72 (120)	5.27 (134)	≈ 0.53 (0.782)
EF61-29-140-0	E61-29-140-0	5.51 (140)	6.06 (154)	≈ 0.54 (0.807)

Choose from the radii below for all of the above sizes

Radius (mm) Example: E61-29-100-100-0

	055	075	100	125	150
R	2.17 (055)	2.95 (075)	3.94 (100)	4.92 (125)	5.91 (150)
H	6.89 (175)	8.46 (215)	10.43 (265)	12.40 (315)	14.37 (365)
D	4.15 (105.5)	4.94 (125.5)	5.93 (150.5)	6.91 (175.5)	7.89 (200.5)
K	8.66 (220)	11.02 (280)	14.17 (360)	17.32 (440)	20.47 (520)

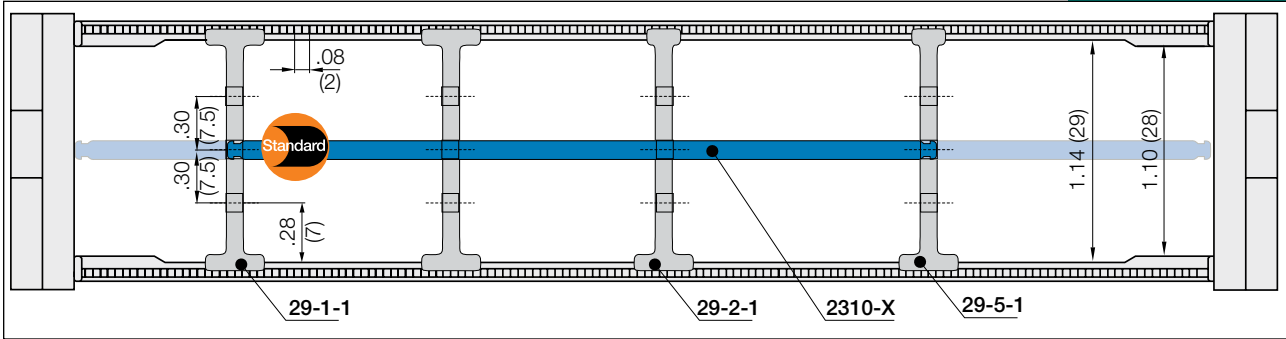

Note: Please maintain a lateral spacing of .51" (13 mm) between the separators and the side links. In the standard configuration separators are assembled every 2nd e-chain® link

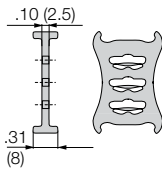

Separator, wide base

Unassembled	Part No. 29-1
Assembled	Part No. 29-1-1

- **Standard separator 29-1 for all applications**

Separator with wide base for maximum locking strength and safe standing in e-chains®.

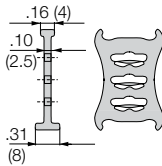

Separator, narrow head

Unassembled	Part No. 29-2
Assembled	Part No. 29-2-1

- **Separator 29-2 For even faster installation**

Firm hold to one side with a wide base, narrow on opposed side for easy cable assembly (slight grip)

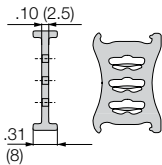

Notch separator, for notch crossbar

Unassembled	Part No. 29-5
Assembled	Part No. 29-5-1

- **Separator 29-5**

Locks safely in .08 (2 mm) increments
For exact positioning in e-chains®. Recommended for side-mounted applications.

Lockable full-width shelves - for the standard interior separation

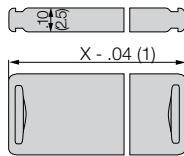

Full width shelf, lockable

Unassembled	Part No. 2300-X
Assembled	Part No. 2310-X

- **Full width shelf, lockable**

Shelf locks safely into separators on both ends, fixed width possible. Separators can be moved freely over the shelf in horizontal direction. Can be arranged at 3 different heights.

Width X in. (mm)	Part No. Unassembled	Part No. Assembled	Width X in. (mm)	Part No. Unassembled	Part No. Assembled	Width X in. (mm)	Part No. Unassembled	Part No. Assembled
0.59 (015)	2300-015	2310-015	2.36 (060)	2300-060	2310-060	3.43 (087)	2300-087	2310-087
0.98 (025)	2300-025	2310-025	2.44 (062)	2300-062	2310-062	3.54 (090)	2300-090	2310-090
1.18 (030)	2300-030	2310-030	2.56 (065)	2300-065	2310-065	3.94 (100)	2300-100	2310-100
1.50 (038)	2300-038	2310-038	2.76 (070)	2300-070	2310-070	4.06 (103)	2300-103	2310-103
1.57 (040)	2300-040	2310-040	2.95 (075)	2300-075	2310-075	4.33 (110)	2300-110	2310-110
1.97 (050)	2300-050	2310-050	3.03 (077)	2300-077	2310-077	4.72 (120)	2300-120	2310-120
2.24 (057)	2300-057	2310-057	3.15 (080)	2300-080	2310-080	4.92 (125)	2300-125	2310-125

Separator with integrated strain relief

Strain relief separator Part No. E6-29-02-Z can be integrated into the mounting bracket and can be placed at any point of the e-chain®. It combines strain relief and interior separation, it can be installed on the first or last e-chain® link and is easy to assemble without any screws.

For more information ► Chapter 10, Strain Relief



PDF: igus.com/e-chain-pdfs
Product information: igus.com/e-chains



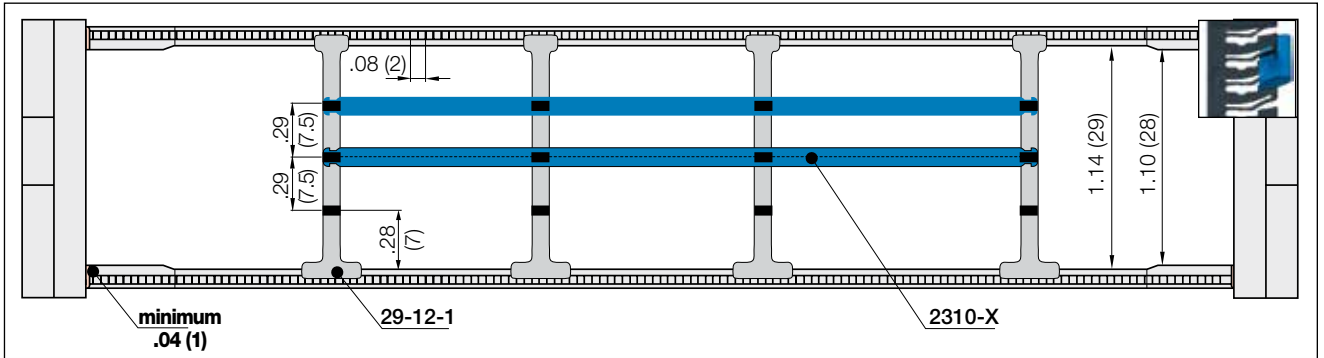

Note: Please maintain a lateral spacing of .04" (1 mm) between the separators and the side links. In the standard configuration separators are assembled every 2nd e-chain® link

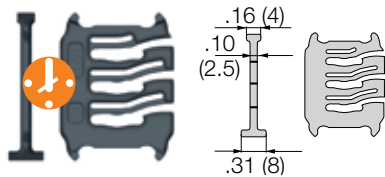

Lean separator	
Unassembled	Part No. 29-12
Assembled	Part No. 29-12-1

- **Lean separators**
New design allows extremely fast fitting of shelves in several layers, which significantly reduces assembly time. Enables extremely fast replacement of individual cables in a very full e-chain®.



- **Lean separator design - several layers of cables fitted quickly, save up to 50%* assembly time**
(*Lean separator vs. standard separator - measured on a 13.12 ft. (4m) long e-chain® fitted with 12 cables in the igus® harnessing factory)



Cleanroom suitable E6-1 series as harnessing readychain® system for a semiconductor industry

e-chain system® E6-1

Series EF61-29 / E61-29

Mounting Brackets - KMA / Strain Relief



EF61-29
E61-29

KMA - Pivoting

- Bolted connection outside of the chain cross-section
- Recommended for unsupported applications (for gliding applications please contact igus®)
- Confined installation conditions
- Attachment capability on all sides

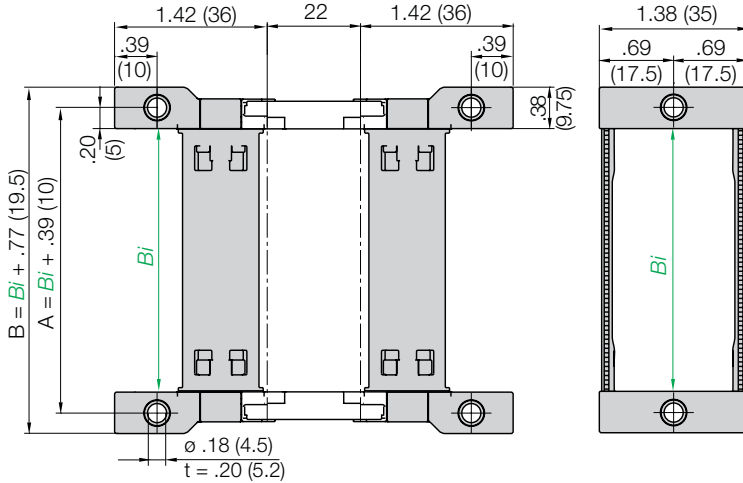
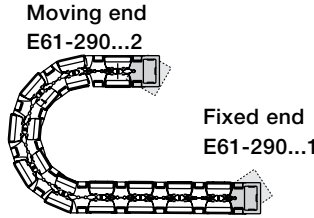

Part Number Structure

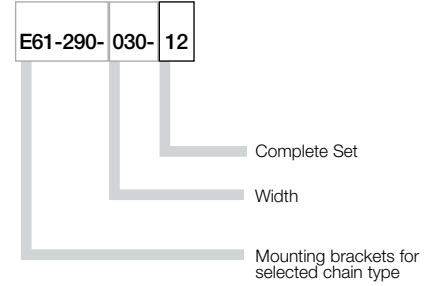

Due to the design of the E6-1 mounting brackets, chain length must be an odd number of links.

Width Index	Part No. Full Set	A in. (mm)	B in. (mm)	Bi in. (mm)
.030	E61-290-030-12	1.57 (40)	1.95 (49.5)	1.18 (30)
.040	E61-290-040-12	1.97 (50)	2.34 (59.5)	1.57 (40)
.050	E61-290-050-12	2.36 (60)	2.74 (69.5)	1.97 (50)
.060	E61-290-060-12	2.76 (70)	3.13 (79.5)	2.36 (60)
.070	E61-290-070-12	3.15 (80)	3.52 (89.5)	2.76 (70)
.080	E61-290-080-12	3.54 (90)	3.92 (99.5)	3.15 (80)
.090	E61-290-090-12	3.94 (100)	4.31 (109.5)	3.54 (90)
.100	E61-290-100-12	4.33 (110)	4.70 (119.5)	3.94 (100)
.110	E61-290-110-12	4.72 (120)	5.10 (129.5)	4.33 (110)
.120	E61-290-120-12	5.12 (130)	5.49 (139.5)	4.72 (120)
.140	E61-290-140-12	5.91 (150)	5.89 (149.5)	5.51 (140)

Tiewrap Plates

Tiewrap plates as an individual part

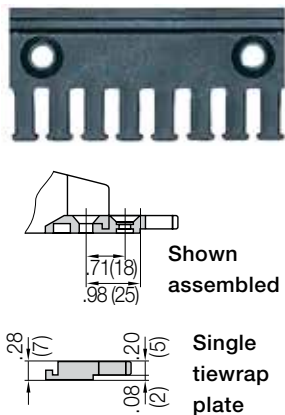

Tiewrap Plates	n Number of Teeth	Dimension C	Dimension B
2020-ZB	3	1.18 (30)	.59 (15)
2030-ZB	4	1.57 (40)	.79 (20)
2040-ZB	5	1.97 (50)	1.18 (30)
2050-ZB	6	2.36 (60)	1.57 (40)
2070-ZB	8	3.15 (80)	2.36 (60)
2090-ZB	9	3.54 (90)	2.76 (70)
2100-ZB	10	3.94 (100)	3.15 (80)
2120-ZB	12	4.72 (120)	3.94 (100)

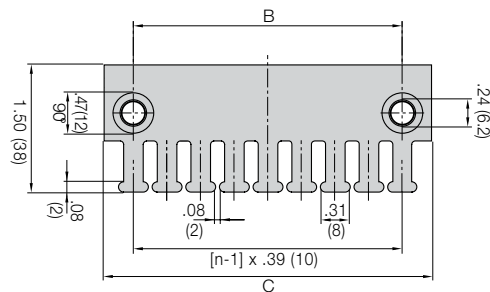

If used with KMA brackets with profile rail please add "KMA" to the end of the part number.

Example: 2020-ZBKMA

Other strain relief elements
 ► Strain Relief, Chapter 10

PDF: igus.com/e-chain-pdfs
 Product information: igus.com/e-chains



Price Index

Series E61-35
Special Features / Options

Extremely low noise
 Test results upon request

Assembly Tips

Snap-open mechanism

Other Installation Methods

Vertical, hanging ≤ 98.4 ft (30 m)

Vertical, standing ≤ 6.56 ft (2 m)

 Side-mounted, unsupported =
 upon request

 Unsupported length of upper run
 ≤ 12.47 ft (3.8 m)

Usage Guidelines

- If a low-noise version is required
- For very high speeds and/or accelerations
- If large stresses and thrust forces are present
- For small bending radii
- If less vibration is required
- Minimal abrasion, suitable for cleanrooms



- For side-mounted applications
 ➤ **Series E2/000**
- For RBR (reverse bending radii)
 ➤ **Series E2/000**
- For high additional loads
 ➤ **Series E2/000**
- For very dirty environments
 ➤ **Series R6**

7.47
Features & Benefits

- 1 KMA mounting brackets with attachment points on all sides
- 2 Small pitch for low-noise, smooth operation
- 3 Crossbars open on either side
- 4 For high speed and high accelerations
- 5 Minimum vibration, high stability and tensile strength
- 6 No pin and bore connection - polymer spring

Order Example: Complete e-chain®

Please indicate chain length or number of links. Example:

 3.28 ft (1 m) **E61-35-100-075-0**

e-chain®

 With 2 separators **E6-35-1-1** assembled every 2nd link

Interior Separation

 1 Set **E61-350-100-12**

Mounting Bracket

e-chain system® E6-1

Series E61-35

Installation Dimensions



E61-35

Short travel, unsupported length

- FL_B = unsupported with permitted sag
 - FL_G = unsupported with straight upper run
- Further information ► Design, Chapter 1

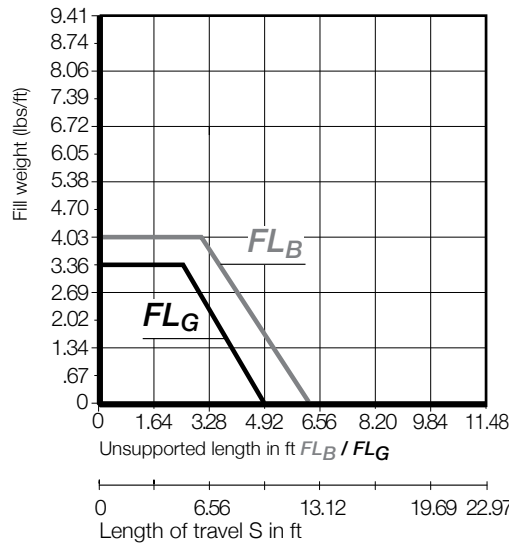
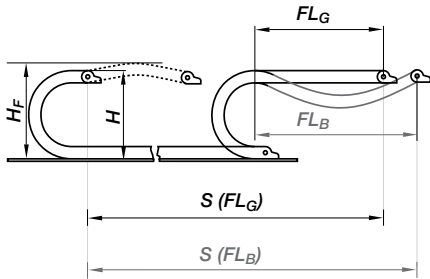

Short Travels - Unsupported



Unsupported e-chains® feature positive camber over short travels. This must be accounted for when specifying the clearance height. Please refer to **Installation dimensions** for further details.

Legend

- S = Length of travel
- R = Bending radius
- H = Nominal clearance height
- D = Overlength e-chain® radius in final position
- $K = \pi \cdot R + \text{safety buffer}$
- H_F = Required clearance height

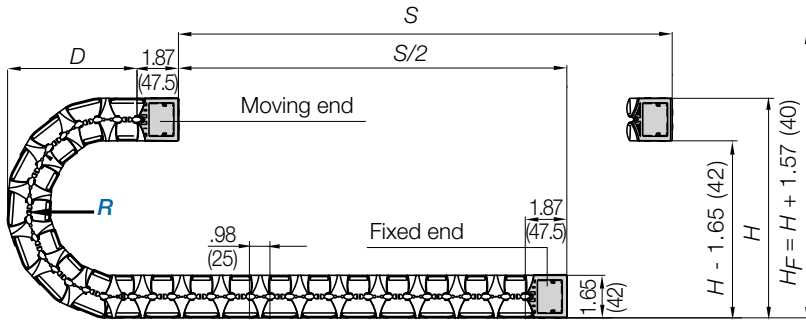

Pitch per link: = .98" (25 mm)
 Links per ft (m): = 12 (40)
 For center mount applications:
 Chain length = $\frac{S}{2} + K$

The required clearance height: $H_F = H + 1.57$ in. (40 mm) (with 1.34 lbs/ft (2.0 kg/m) fill weight). Please consult igus® if space is particularly restricted.

R	2.17 (055)	2.95 (075)	3.94 (100)	4.92 (125)	5.91 (150)
H	7.56 (192)	9.13 (232)	11.10 (282)	13.10 (332)	15.04 (382)
D	4.47 (113.5)	5.26 (133.5)	6.24 (158.5)	7.22 (183.5)	8.21 (208.5)
K	8.86 (225)	11.42 (290)	14.37 (365)	17.52 (445)	20.67 (525)

If a gliding application is required for a long travel, please consult igus®.

Aluminum support tray

- Corrosion-resistant and seawater-resistant aluminum rails with adjustable width
- Noise-reducing glide strip integrated as standard
- Easy installation and connection of the e-chain®
- Open design - dirt and debris fall through

More information ► Chapter 9



Speed / acceleration FL_G	max. 65.6 ft/s (20 m/s) / max. 656 ft/s ² (200 m/s ²)
Speed / acceleration FL_B	max. 9.84 ft/s (3 m/s) / max. 19.69 ft/s ² (6 m/s ²)
Gliding speed / acceleration (maximum)	upon request
Permitted temperature, igumid G	upon request
Flammability Class	VDE 0304 IIC UL94 HB

Technical Data



Details of material properties

► Design, Chapter 1

1.38

PDF: igus.com/e-chain-pdfs
 Product information: igus.com/e-chains



Series E61-35 - e-chain® - crossbars removable along the inner and outer radius

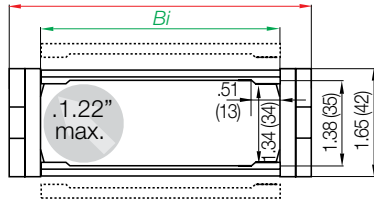

Part Number Structure

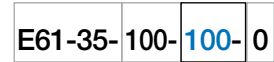

- Color - Black
- Bending radius
- Width
- Series

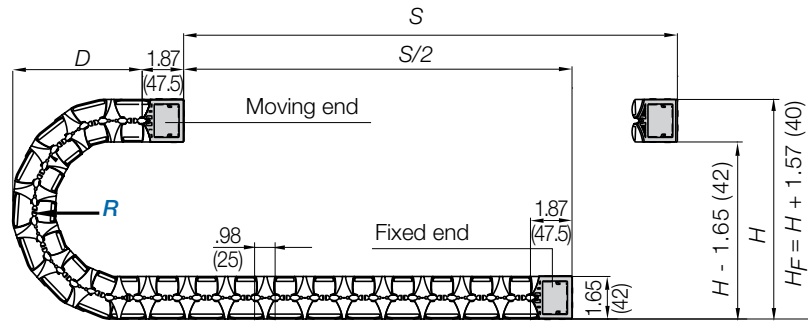

Supplement part number with required radius. Example: E61-35-100--0

Pitch: .98 in. (25 mm) per link links/ft (m) = 12 (40)

Part Number	Bi in. (mm)	Ba in. (mm)	Weight lbs/ft (kg/m)
E61-35-030- <input type="text"/> -0	1.18 (30)	1.81 (46)	≈ 0.439 (0.653)
E61-35-040- <input type="text"/> -0	1.57 (40)	2.20 (56)	≈ 0.454 (0.675)
E61-35-050- <input type="text"/> -0	1.97 (50)	2.60 (66)	≈ 0.468 (0.696)
E61-35-060- <input type="text"/> -0	2.36 (60)	2.99 (76)	≈ 0.482 (0.718)
E61-35-070- <input type="text"/> -0	2.76 (70)	3.39 (86)	≈ 0.497 (0.739)
E61-35-080- <input type="text"/> -0	3.15 (80)	3.78 (96)	≈ 0.511 (0.761)
E61-35-090- <input type="text"/> -0	3.54 (90)	4.17 (106)	≈ 0.526 (0.783)
E61-35-100- <input type="text"/> -0	3.94 (100)	4.57 (116)	≈ 0.540 (0.804)
E61-35-110- <input type="text"/> -0	4.33 (110)	4.96 (126)	≈ 0.555 (0.826)
E61-35-120- <input type="text"/> -0	4.72 (120)	5.35 (136)	≈ 0.570 (0.848)
E61-35-140- <input type="text"/> -0	5.51 (140)	6.14 (156)	≈ 0.599 (0.891)

Choose from the radii below for all of the above sizes
Radius (mm) Example: E61-35-100--0

	055	075	100	125	150
R	2.17 (055)	2.95 (075)	3.94 (100)	4.92 (125)	5.91 (150)
H	7.56 (192)	9.13 (232)	11.10 (282)	13.10 (332)	15.04 (382)
D	4.47 (113.5)	5.26 (133.5)	6.24 (158.5)	7.22 (183.5)	8.21 (208.5)
K	8.86 (225)	11.42 (290)	14.37 (365)	17.52 (445)	20.67 (525)

e-chain system® E6-1
Series E61-35
Interior Separation



E61-35

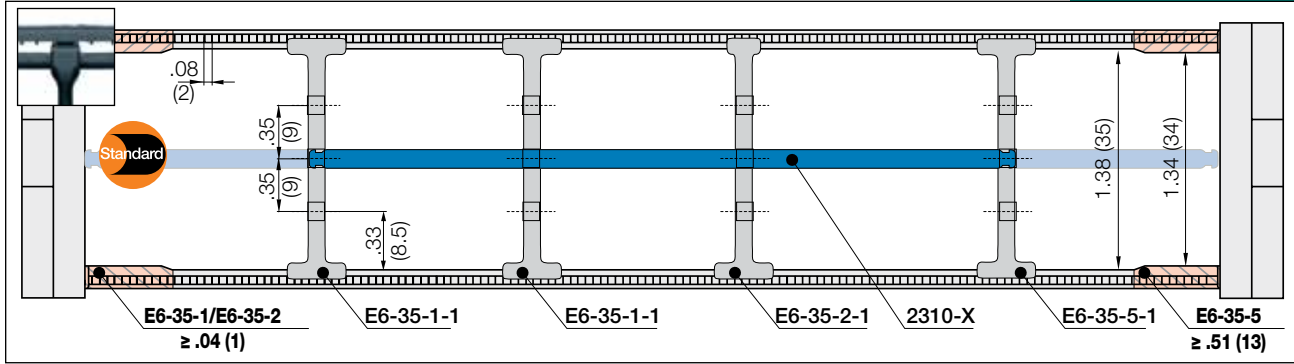

Note: Please maintain a lateral spacing of .51" (13 mm) between the separators and the side links. In the standard configuration separators are assembled every 2nd e-chain® link

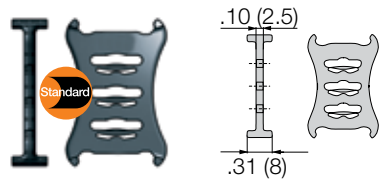

Separator, wide base

Unassembled Part No. E6-35-1

Assembled Part No. E6-35-1-1

- Standard separator E6-35-1 for all applications

Separator with wide base for maximum locking strength and safe standing in e-chains®.

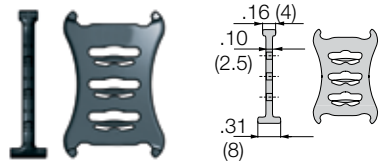

Separator, narrow head

Unassembled Part No. E6-35-2

Assembled Part No. E6-35-2-1

- Separator E6-35-2 For even faster installation

Firm hold to one side with a wide base, narrow on opposed side for easy cable assembly (slight grip)

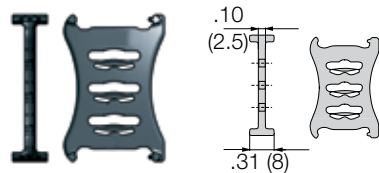

Notch separator, for notch crossbar

Unassembled Part No. E6-35-5

Assembled Part No. E6-35-5-1

- Separator E6-35-5

Locks safely in .08 (2 mm) increments For exact positioning in e-chains®. Recommended for side-mounted applications.

Lockable full-width shelves - for the standard interior separation

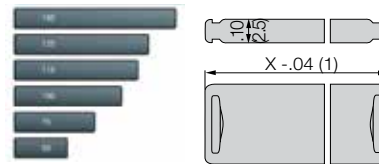

Full width shelf, lockable

Unassembled Part No. 2300-X

Assembled Part No. 2310-X

- Full width shelf, lockable

Shelf locks safely into separators on both ends, fixed width possible. Separators can be moved freely over the shelf in horizontal direction. Can be arranged at 3 different heights.

Width X in. (mm)	Part No. Unassembled	Part No. Assembled	Width X in. (mm)	Part No. Unassembled	Part No. Assembled	Width X in. (mm)	Part No. Unassembled	Part No. Assembled
0.59 (015)	2300-015	2310-015	2.36 (060)	2300-060	2310-060	3.43 (087)	2300-087	2310-087
0.98 (025)	2300-025	2310-025	2.44 (062)	2300-062	2310-062	3.54 (090)	2300-090	2310-090
1.18 (030)	2300-030	2310-030	2.56 (065)	2300-065	2310-065	3.94 (100)	2300-100	2310-100
1.50 (038)	2300-038	2310-038	2.76 (070)	2300-070	2310-070	4.06 (103)	2300-103	2310-103
1.57 (040)	2300-040	2310-040	2.95 (075)	2300-075	2310-075	4.33 (110)	2300-110	2310-110
1.97 (050)	2300-050	2310-050	3.03 (077)	2300-077	2310-077	4.72 (120)	2300-120	2310-120
2.24 (057)	2300-057	2310-057	3.15 (080)	2300-080	2310-080	4.92 (125)	2300-125	2310-125

Separator with integrated strain relief

Strain relief separator Part No. E6-35-02-Z can be integrated into the mounting bracket and can be placed at any point of the e-chain®. It combines strain relief and interior separation, it can be installed on the first or last e-chain® link and is easy to assemble without any screws.

For more information ► Chapter 10, Strain Relief



PDF: igus.com/e-chain-pdfs
Product information: igus.com/e-chains





KMA - Pivoting

- Bolted connection outside of the chain cross-section
- Recommended for unsupported applications (for gliding applications please contact igus®)
- Confined installation conditions
- Attachment capability on all sides

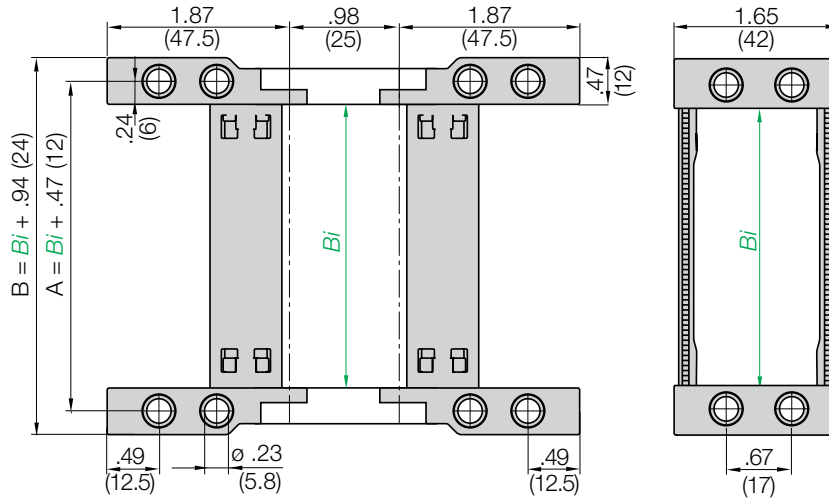
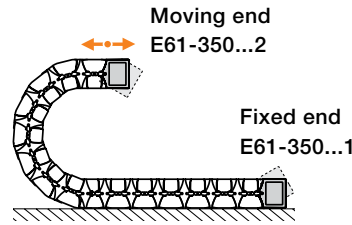

Part Number Structure

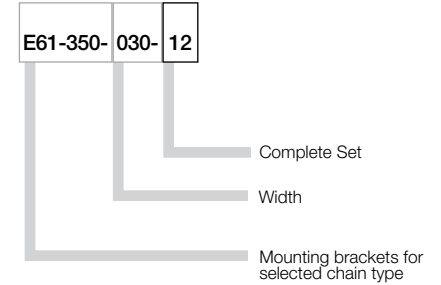

Due to the design of the E6-1 mounting brackets, chain length must be an odd number of links.

Width Index	Part No. Full Set	A in. (mm)	B in. (mm)	Bi in. (mm)
.030	E61-350-030-12	1.57 (40)	1.95 (49.5)	1.18 (30)
.040	E61-350-040-12	1.97 (50)	2.34 (59.5)	1.57 (40)
.050	E61-350-050-12	2.36 (60)	2.74 (69.5)	1.97 (50)
.060	E61-350-060-12	2.76 (70)	3.13 (79.5)	2.36 (60)
.070	E61-350-070-12	3.15 (80)	3.52 (89.5)	2.76 (70)
.080	E61-350-080-12	3.54 (90)	3.92 (99.5)	3.15 (80)
.090	E61-350-090-12	3.94 (100)	4.31 (109.5)	3.54 (90)
.100	E61-350-100-12	4.33 (110)	4.70 (119.5)	3.94 (100)
.110	E61-350-110-12	4.72 (120)	5.10 (129.5)	4.33 (110)
.120	E61-350-120-12	5.12 (130)	5.49 (139.5)	4.72 (120)
.140	E61-350-140-12	5.91 (150)	5.89 (149.5)	5.51 (140)

Tiewrap Plates

Tiewrap plates as an individual part

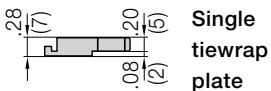
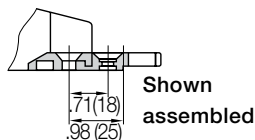

Tiewrap Plates	n Number of Teeth	Dimension C	Dimension B
2020-ZB	3	1.18 (30)	.59 (15)
2030-ZB	4	1.57 (40)	.79 (20)
2040-ZB	5	1.97 (50)	1.18 (30)
2050-ZB	6	2.36 (60)	1.57 (40)
2070-ZB	8	3.15 (80)	2.36 (60)
2090-ZB	9	3.54 (90)	2.76 (70)
2100-ZB	10	3.94 (100)	3.15 (80)
2120-ZB	12	4.72 (120)	3.94 (100)

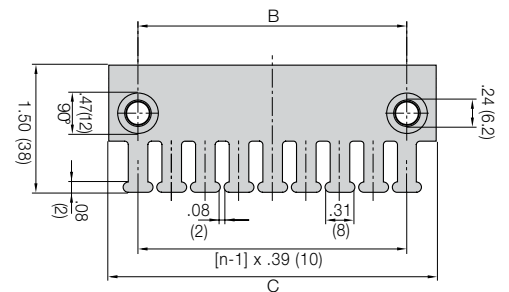

If used with KMA brackets with profile rail please add "KMA" to the end of the part number.

Example: 2020-ZBKMA

Other strain relief elements

➤ **Strain Relief, Chapter 10**

PDF: igus.com/e-chain-pdfs
Product information: igus.com/e-chains



Price Index

Series E61-40

Special Features / Options

Extremely low noise
 Test results upon request

Assembly Tips

snap-open mechanism

Other Installation Methods

Vertical, hanging ≤ 98.4 ft (30 m)

Vertical, standing ≤ 6.56 ft (2 m)

Side-mounted, unsupported =
upon requestUnsupported length of upper run
≤ 16.4 ft (5 m)
Usage Guidelines

- If a low-noise version is required
- For very high speeds and/or accelerations
- If large stresses and thrust forces are present
- For small bending radii
- If less vibration is required
- Minimal abrasion, suitable for cleanrooms



- For side-mounted applications
➤ **Series E2/000**
- For RBR (reverse bending radii)
➤ **Series E2/000**
- For high additional loads
➤ **Series E2/000**
- For very dirty environments
➤ **Series R6**

Features & Benefits

- ➊ KMA mounting brackets with attachment points on all sides
- ➋ Small pitch for low-noise, smooth operation
- ➌ Crossbars open on either side
- ➍ For high speed and high accelerations
- ➎ Minimum vibration, high stability and tensile strength
- ➏ No pin and bore connection - polymer spring

Order Example: Complete e-chain®

Please indicate chain length or number of links. Example:

3.28 ft (1 m) **E61-40-100-075-0**

e-chain®

With 2 separators **E6-40-1-1** assembled every 2nd link

Interior Separation

1 Set **E61-400-100-12**

Mounting Bracket

e-chain system® E6-1

Series E61-40

Installation Dimensions



E61-40

Short travel, unsupported length

- FL_B = unsupported with permitted sag
 - FL_G = unsupported with straight upper run
- Further information ► Design, Chapter 1

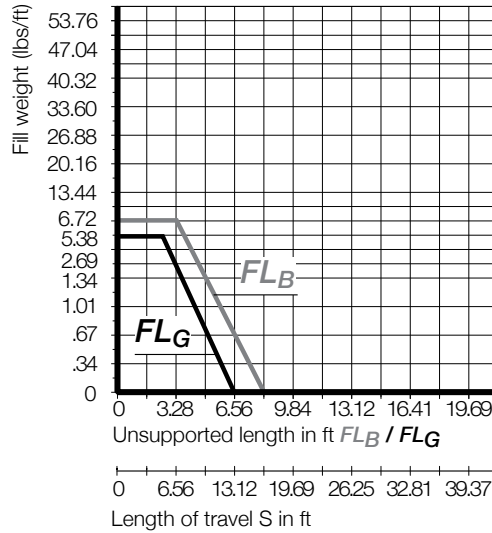
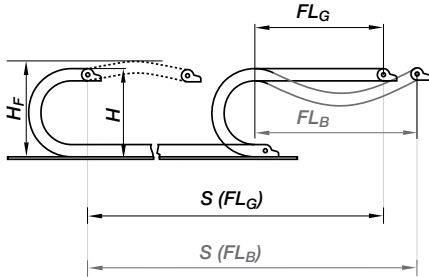

Short Travels - Unsupported



Unsupported e-chains® feature positive camber over short travels. This must be accounted for when specifying the clearance height. Please refer to **Installation dimensions** for further details.

Legend

- S = Length of travel
- R = Bending radius
- H = Nominal clearance height
- D = Overlength e-chain® radius in final position
- $K = \pi \cdot R + \text{safety buffer}$
- H_F = Required clearance height

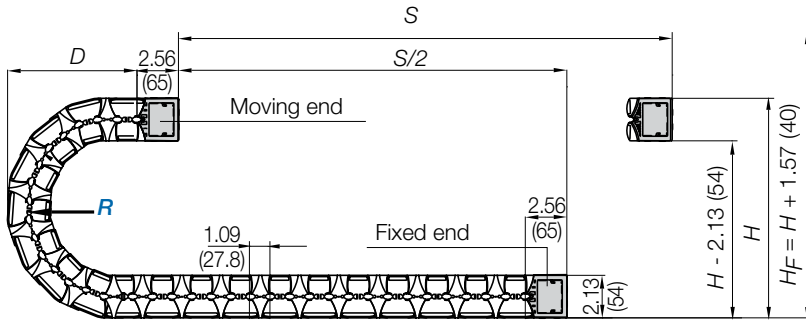

Pitch per link = 1.09" (27.8 mm)
 Links per ft (m) = 11 (36)
 For center mount applications:
 Chain length = $\frac{S}{2} + K$

The required clearance height: $H_F = H + 1.57$ in. (40 mm) (with 1.34 lbs/ft (2.0 kg/m) fill weight). Please consult igus® if space is particularly restricted.

R	2.48 (063)	2.95 (075)	3.94 (100)	4.92 (125)	5.91 (150)	7.87 (200)
H	8.66 (220)	9.61 (244)	11.57 (294)	13.54 (344)	15.51 (394)	19.45 (494)
D	5.20 (132)	5.67 (144)	6.65 (169)	7.64 (194)	8.62 (219)	10.59 (269)
K	10.04 (255)	11.61 (295)	14.57 (370)	17.72 (450)	2.09 (530)	26.97 (685)



i If a gliding application is required for a long travel, please consult igus®.

Aluminum support tray

- Corrosion-resistant and seawater-resistant aluminum rails with adjustable width
- Noise-reducing glide strip integrated as standard
- Easy installation and connection of the e-chain®
- Open design - dirt and debris fall through

More information ► Chapter 9



Speed / acceleration FL_G	max. 65.6 ft/s (20 m/s) / max. 656 ft/s ² (200 m/s ²)
Speed / acceleration FL_B	max. 9.84 ft/s (3 m/s) / max. 19.69 ft/s ² (6 m/s ²)
Gliding speed / acceleration (maximum)	upon request
Permitted temperature, igumid G	upon request
Flammability Class	VDE 0304 IIC UL94 HB

Technical Data



Details of material properties

► Design, Chapter 1

157

PDF: igus.com/e-chain-pdfs
 Product information: igus.com/e-chains



Series E61-40 - e-chain® - crossbars removable along the inner and outer radius

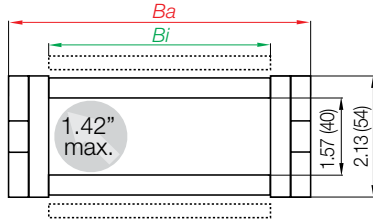

Part Number Structure

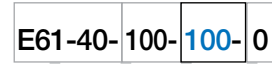

- Color - Black
- Bending radius
- Width
- Series

Telephone 1-800-521-2747

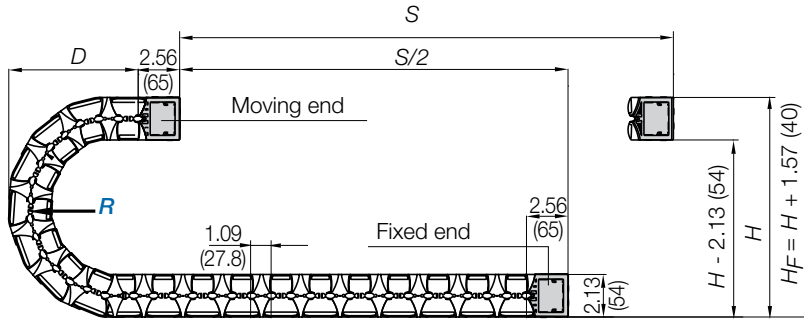

Supplement part number with required radius. Example: E61-40-100-**100**-0
Pitch: 1.09 in. (27.8 mm) per link links/ft (m) = 11 (36)

Part Number	Bi in. (mm)	Ba in. (mm)	Weight lbs/ft (kg/m)
E61-40-040-□-0	1.57 (40)	2.20 (56)	≈ 0.613 (0.913)
E61-40-050-□-0	1.97 (50)	2.60 (66)	≈ 0.638 (0.950)
E61-40-052-□-0	2.05 (52)	2.68 (68)	≈ 0.643 (0.957)
E61-40-062-□-0	2.44 (62)	3.07 (78)	≈ 0.668 (0.994)
E61-40-070-□-0	2.76 (70)	3.39 (86)	≈ 0.687 (1.023)
E61-40-075-□-0	2.95 (75)	3.58 (91)	≈ 0.700 (1.042)
E61-40-087-□-0	3.43 (87)	4.06 (103)	≈ 0.716 (1.066)
E61-40-100-□-0	3.94 (100)	4.57 (116)	≈ 0.762 (1.134)
E61-40-125-□-0	4.92 (125)	5.55 (141)	≈ 0.824 (1.226)
E61-40-150-□-0	5.91 (150)	6.54 (166)	≈ 0.886 (1.318)
E61-40-175-□-0	6.89 (175)	7.52 (191)	≈ 0.947 (1.410)
E61-40-200-□-0	7.87 (200)	8.50 (216)	≈ 1.009 (1.502)
E61-40-225-□-0	8.86 (225)	9.49 (241)	≈ 1.072 (1.595)
E61-40-250-□-0	9.84 (250)	10.47 (266)	≈ 1.134 (1.687)
E61-40-275-□-0	10.83 (275)	11.46 (291)	≈ 1.195 (1.779)
E61-40-300-□-0	11.81 (300)	12.44 (316)	≈ 1.257 (1.871)

Choose from the radii below for all of the above sizes

Radius (mm) Example: E61-40-100-**100**-0

	063	075	100	125	150	150
R	2.48 (063)	2.95 (075)	3.94 (100)	4.92 (125)	5.91 (150)	7.87 (200)
H	8.66 (220)	9.61 (244)	11.57 (294)	13.54 (344)	15.51 (394)	19.45 (494)
D	5.20 (132)	5.67 (144)	6.65 (169)	7.64 (194)	8.62 (219)	10.59 (269)
K	10.04 (255)	11.61 (295)	14.57 (370)	17.72 (450)	2.09 (530)	26.97 (685)

Internet: igus.com
email: sales@igus.com
QuickSpec: igus.com/quickspec

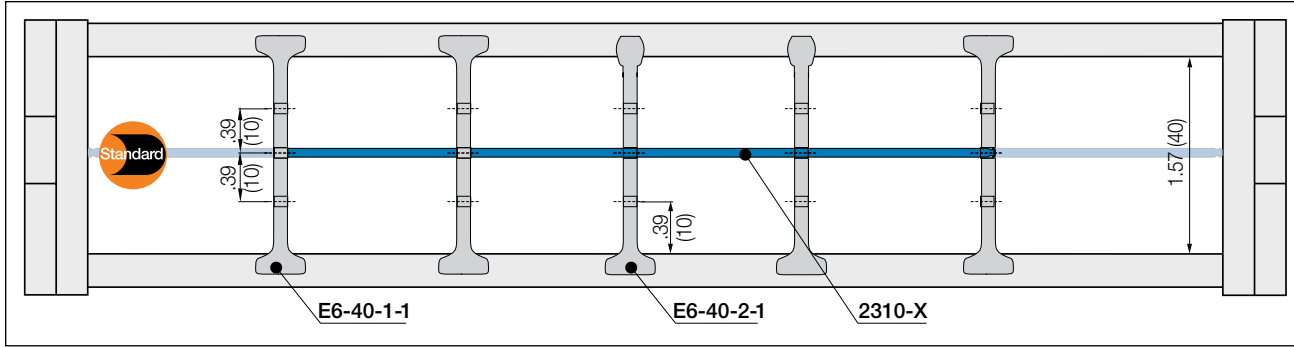

Note: Please maintain a lateral spacing of .51" (13 mm) between the separators and the side links. In the standard configuration separators are assembled every 2nd e-chain® link

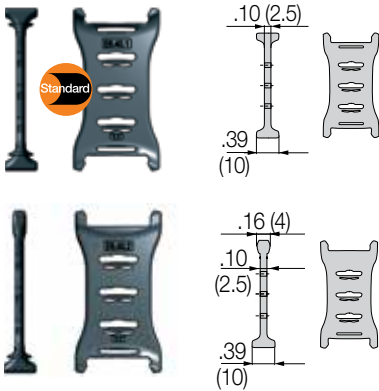

Separator, wide base
Unassembled Part No. E6-40-1
Assembled Part No. E6-40-1-1

- **Standard separator E6-40-1 for all applications**
Separator with wide base for maximum locking strength and safe standing in e-chains®.

Separator, narrow head
Unassembled Part No. E6-40-2
Assembled Part No. E6-40-2-1

- **Separator E6-40-2 For even faster installation**
Firm hold to one side with a wide base, narrow on opposed side for easy cable assembly (slight grip)

Lockable full-width shelves - for the standard interior separation

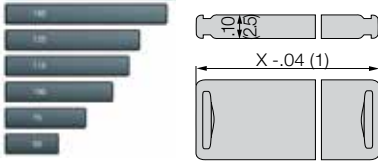

Full width shelf, lockable
Unassembled Part No. 2300-X
Assembled Part No. 2310-X

- **Full width shelf, lockable**
Shelf locks safely into separators on both ends, fixed width possible. Separators can be moved freely over the shelf in horizontal direction. Can be arranged at 3 different heights.

Width X in. (mm)	Part No. Unassembled	Part No. Assembled	Width X in. (mm)	Part No. Unassembled	Part No. Assembled	Width X in. (mm)	Part No. Unassembled	Part No. Assembled
0.59 (015)	2300-015	2310-015	2.36 (060)	2300-060	2310-060	3.43 (087)	2300-087	2310-087
0.98 (025)	2300-025	2310-025	2.44 (062)	2300-062	2310-062	3.54 (090)	2300-090	2310-090
1.18 (030)	2300-030	2310-030	2.56 (065)	2300-065	2310-065	3.94 (100)	2300-100	2310-100
1.50 (038)	2300-038	2310-038	2.76 (070)	2300-070	2310-070	4.06 (103)	2300-103	2310-103
1.57 (040)	2300-040	2310-040	2.95 (075)	2300-075	2310-075	4.33 (110)	2300-110	2310-110
1.97 (050)	2300-050	2310-050	3.03 (077)	2300-077	2310-077	4.72 (120)	2300-120	2310-120
2.24 (057)	2300-057	2310-057	3.15 (080)	2300-080	2310-080	4.92 (125)	2300-125	2310-125

Separator with integrated strain relief

Strain relief separator Part No. E6-40-02-Z can be integrated into the mounting bracket and can be placed at any point of the e-chain®. It combines strain relief and interior separation, it can be installed on the first or last e-chain® link and is easy to assemble without any screws.

For more information ► Chapter 10, Strain Relief



PDF: igus.com/e-chain-pdfs
Product information: igus.com/e-chains



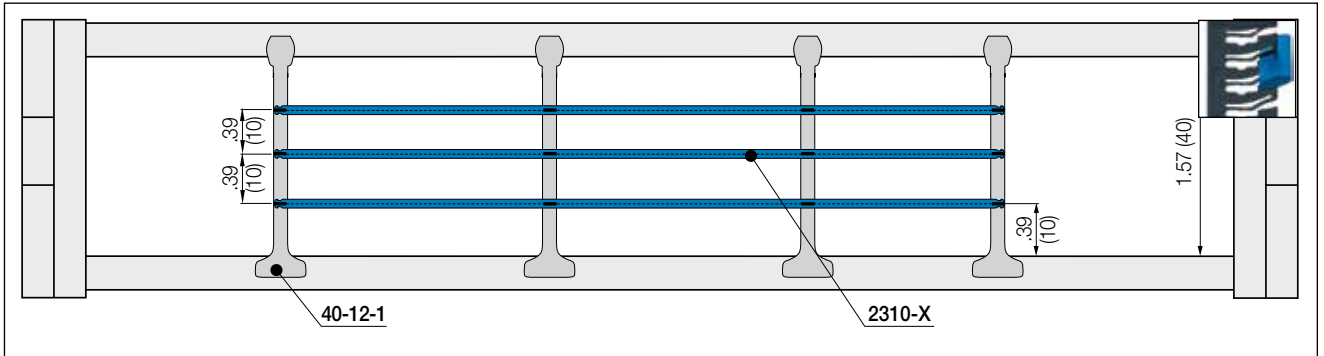

Note: No lateral gap to side links is necessary.

In the standard configuration separators are assembled every 2nd e-chain® link

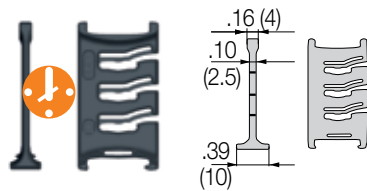

Lean separator

Unassembled Part No. 40-12

Assembled Part No. 40-12-1



• **Lean separators**

New design allows extremely fast fitting of shelves in several layers, which significantly reduces assembly time. Enables extremely fast replacement of individual cables in a very full e-chain®.

• **Lean separator design - several layers of cables fitted quickly, save up to 50%* assembly time**

(*Lean separator vs. standard separator - measured on a 13.12 ft (4m) long e-chain® fitted with 12 cables in the igus® harnessing factory)



Very small bend radii are possible with chainflex® CF98 control cable in this E6-1 readychain® system. It offers smooth operation and is suitable for cleanrooms

e-chain system® E6-1

Series E61-40

Mounting Brackets - KMA



E61-40

KMA - Pivoting

- Bolted connection outside of the chain cross-section
- Recommended for unsupported applications (for gliding applications please contact igus®)
- Confined installation conditions
- Attachment capability on all sides

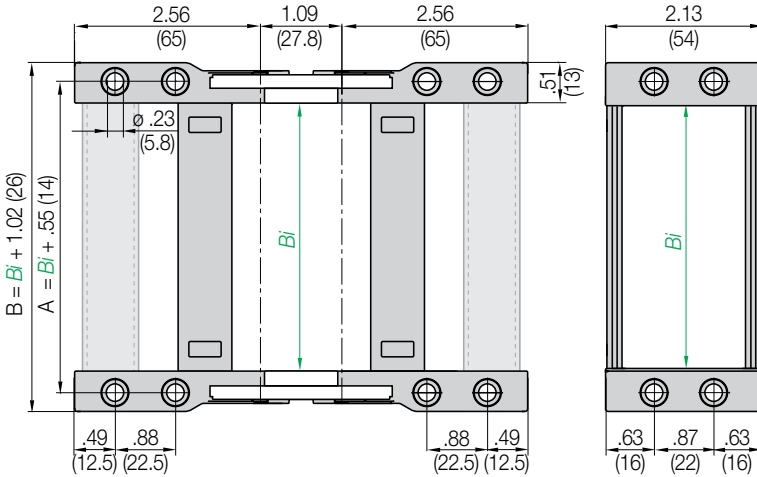
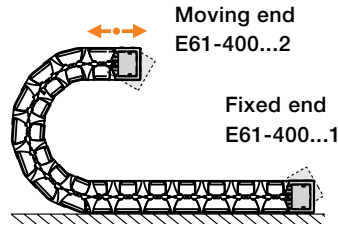

Part Number Structure

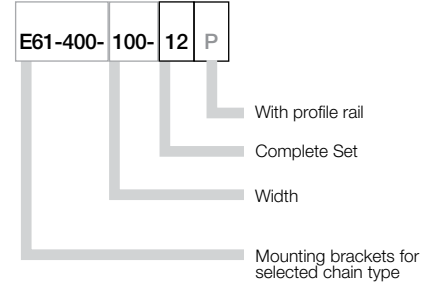

Due to the design of the E6-1 mounting brackets, chain length must be an odd number of links.

For Series	Part No. Full Set Without Profile Rail	Part No. Full Set With Profile Rail	Dimension A		Dimension B		Bi	
			in.	(mm)	in.	(mm)	in.	(mm)
.040	E61-400-040-12	E61-400-040-12P	2.13	(54)	2.60	(66)	1.57	(40)
.050	E61-400-050-12	E61-400-050-12P	2.52	(64)	2.99	(76)	1.97	(50)
.052	E61-400-052-12	E61-400-052-12P	2.66	(66)	3.07	(78)	2.05	(52)
.062	E61-400-062-12	E61-400-062-12P	2.99	(76)	3.46	(88)	2.44	(62)
.070	E61-400-070-12	E61-400-070-12P	3.31	(84)	3.78	(96)	2.76	(70)
.075	E61-400-075-12	E61-400-075-12P	3.50	(89)	3.98	(101)	2.95	(75)
.087	E61-400-087-12	E61-400-087-12P	3.98	(101)	4.45	(113)	3.42	(87)
.100	E61-400-100-12	E61-400-100-12P	4.49	(114)	4.96	(126)	3.94	(100)
.125	E61-400-125-12	E61-400-125-12P	5.47	(139)	5.94	(151)	4.92	(125)
.150	E61-400-150-12	E61-400-150-12P	6.46	(164)	6.93	(176)	5.91	(150)
.175	E61-400-175-12	E61-400-175-12P	7.44	(189)	7.91	(201)	6.89	(175)
.200	E61-400-200-12	E61-400-200-12P	8.43	(214)	8.90	(226)	7.87	(200)
.225	E61-400-225-12	E61-400-225-12P	9.41	(239)	9.88	(251)	8.86	(225)
.250	E61-400-250-12	E61-400-250-12P	10.39	(264)	10.87	(276)	9.84	(250)
.275	E61-400-275-12	E61-400-275-12P	11.38	(289)	11.85	(301)	10.83	(275)
.300	E61-400-300-12	E61-400-300-12P	12.36	(314)	12.83	(326)	11.81	(300)

PDF: igus.com/e-chain-pdfs
 Product information: igus.com/e-chains



Tiewrap Plates

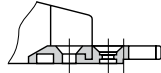

Shown
assembled

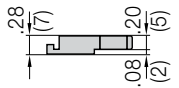

Single
tiewrap
plate

Tiewrap plates as an individual part

Tiewrap Plates	n Number of Teeth	Dimension C	Dimension B
2020-ZB	3	1.18 (30)	.59 (15)
2030-ZB	4	1.57 (40)	.79 (20)
2040-ZB	5	1.97 (50)	1.18 (30)
2050-ZB	6	2.36 (60)	1.57 (40)
2070-ZB	8	3.15 (80)	2.36 (60)
2090-ZB	9	3.54 (90)	2.76 (70)
2100-ZB	10	3.94 (100)	3.15 (80)
2120-ZB	12	4.72 (120)	3.94 (100)

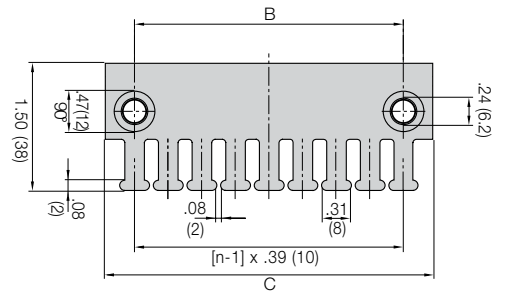

If used with KMA brackets with profile rail please add "KMA" to the end of the part number.

Example: 2020-ZBKMA

Other strain relief elements

► **Strain Relief, Chapter 10**



PDF: igus.com/e-chain-pdfs
Product information: igus.com/e-chains



Price Index

Series E61-52
Special Features / Options

Extremely low noise
 Test results upon request

Assembly Tips

snap-open mechanism

Other Installation Methods

Vertical, hanging ≤ 164 ft (50 m)

Vertical, standing ≤ 6.56 ft (2 m)

 Side-mounted, unsupported =
 upon request

 Unsupported length of upper run
 ≤ 19.69 ft (6 m)

Usage Guidelines

- If a low-noise version is required
- For very high speeds and/or accelerations
- If large stresses and thrust forces are present
- For small bending radii
- If less vibration is required
- Minimal abrasion, suitable for cleanrooms



- For side-mounted applications
 - **Series E2/000**
- For RBR (reverse bending radii)
 - **Series E2/000**
- For high additional loads
 - **Series E2/000**
- For very dirty environments
 - **Series R6**

Features & Benefits

- ➊ KMA mounting brackets with attachment points on all sides
- ➋ Small pitch for low-noise, smooth operation
- ➌ Crossbars open on either side
- ➍ For high speed and high accelerations
- ➎ Minimum vibration, high stability and tensile strength
- ➏ No pin and bore connection - polymer spring

Order Example: Complete e-chain®

Please indicate chain length or number of links. Example:

 3.28 ft (1 m) **E61-52-100-075-0**

e-chain®

 With 2 separators **E6-52-1-1** assembled every 2nd link

Interior Separation

 1 Set **E61-520-100-12**

Mounting Bracket

e-chain system® E6-1

Series E61-52

Installation Dimensions



E61-52

Short travel, unsupported length

- FL_B = unsupported with permitted sag
 - FL_G = unsupported with straight upper run
- Further information ► Design, Chapter 1

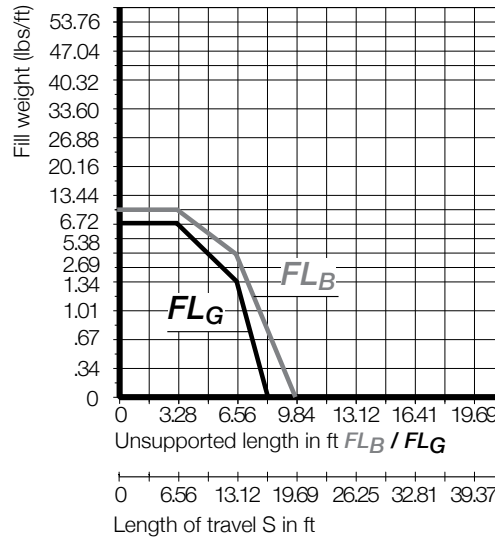
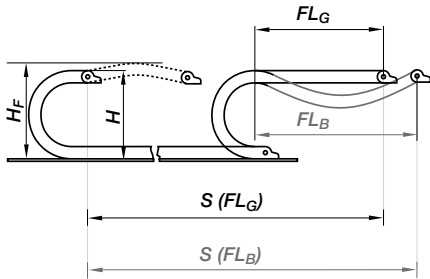

Short Travels - Unsupported

2.05



Unsupported e-chains® feature positive camber over short travels. This must be accounted for when specifying the clearance height. Please refer to **Installation dimensions** for further details.

Legend

- S = Length of travel
- R = Bending radius
- H = Nominal clearance height
- D = Overlength e-chain® radius in final position
- $K = \pi \cdot R + \text{safety buffer}$
- H_F = Required clearance height

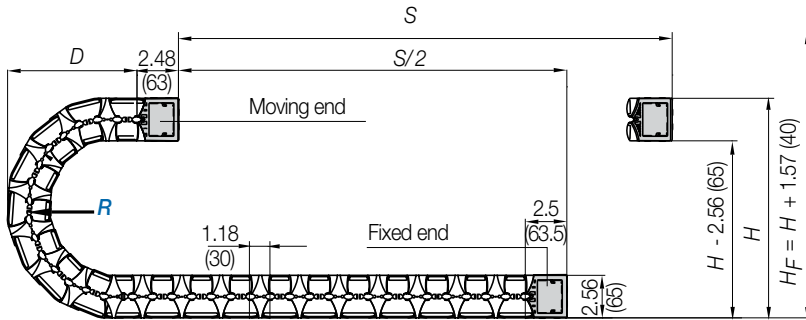

Pitch per link = 1.18" (30 mm)
 Links per ft (m) = 10 (34)
 For center mount applications:
 Chain length = $\frac{S}{2} + K$

The required clearance height: $H_F = H + 1.57$ in. (40 mm) (with 1.34 lbs/ft (2.0 kg/m) fill weight). Please consult igus® if space is particularly restricted.

R	2.95 (075)	3.94 (100)	4.92 (125)	5.91 (150)
H	10.43 (265)	12.40 (315)	14.37 (365)	16.34 (415)
D	6.02 (153)	7.01 (178)	7.99 (203)	8.98 (228)
K	11.81 (300)	14.76 (375)	17.91 (455)	21.06 (535)

i If a gliding application is required for a long travel, please consult igus®.

Steel support tray for support of lower run

- Simple one-piece support trays for the lower run
- To your requirements and specifications
- 4 options available

More information ► Chapter 9



Speed / acceleration FL_G	max. 65.6 ft/s (20 m/s) / max. 656 ft/s ² (200 m/s ²)
Speed / acceleration FL_B	max. 9.84 ft/s (3 m/s) / max. 19.69 ft/s ² (6 m/s ²)
Gliding speed / acceleration (maximum)	upon request
Permitted temperature, igumid G	upon request
Flammability Class	VDE 0304 IIC UL94 HB

Technical Data



Details of material properties

► Design, Chapter 1

PDF: igus.com/e-chain-pdfs
 Product information: igus.com/e-chains

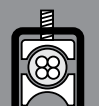

Series E61-52 - e-chain® -
crossbars removable along the inner and outer radius

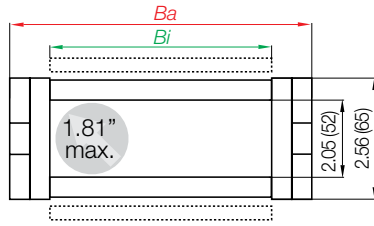

Part Number Structure

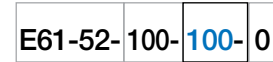

- Color - Black
- Bending radius
- Width
- Series

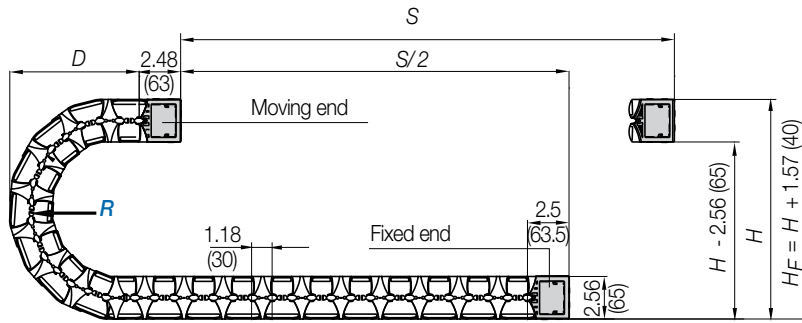

Supplement part number with required radius. Example: E61-52-100-100-0

Pitch: 1.18 in. (30 mm) per link links/ft (m) = 10 (34)

Part Number	Bi in. (mm)	Ba in. (mm)	Weight lbs/ft (kg/m)
E61-52-040- -0	1.57 (40)	2.52 (64)	≈ 1.128 (1.679)
E61-52-050- -0	1.97 (50)	2.91 (74)	≈ 1.158 (1.724)
E61-52-052- -0	2.05 (52)	2.99 (76)	≈ 1.165 (1.733)
E61-52-062- -0	2.44 (62)	3.41 (86.5)	≈ 1.196 (1.780)
E61-52-070- -0	2.76 (70)	3.70 (94)	≈ 1.219 (1.814)
E61-52-075- -0	2.95 (75)	3.90 (99)	≈ 1.234 (1.836)
E61-52-087- -0	3.43 (87)	4.39 (111.5)	≈ 1.271 (1.892)
E61-52-100- -0	3.94 (100)	4.88 (124)	≈ 1.309 (1.948)
E61-52-125- -0	4.92 (125)	5.87 (149)	≈ 1.384 (2.060)
E61-52-150- -0	5.91 (150)	6.85 (174)	≈ 1.460 (2.172)
E61-52-175- -0	6.89 (175)	7.83 (199)	≈ 1.534 (2.283)
E61-52-200- -0	7.87 (200)	8.81 (224)	≈ 1.609 (2.395)
E61-52-225- -0	8.86 (225)	9.80 (249)	≈ 1.685 (2.507)
E61-52-250- -0	9.84 (250)	10.79 (274)	≈ 1.760 (2.619)
E61-52-275- -0	10.83 (275)	11.77 (299)	≈ 1.835 (2.731)
E61-52-300- -0	11.81 (300)	12.76 (324)	≈ 1.910 (2.843)

Choose from the radii below for all of the above sizes
Radius (mm) Example: E61-52-100-100-0

	075	100	125	150
R	2.95 (075)	3.94 (100)	4.92 (125)	5.91 (150)
H	10.43 (265)	12.40 (315)	14.37 (365)	16.34 (415)
D	6.02 (153)	7.01 (178)	7.99 (203)	8.98 (228)
K	11.81 (300)	14.76 (375)	17.91 (455)	21.06 (535)

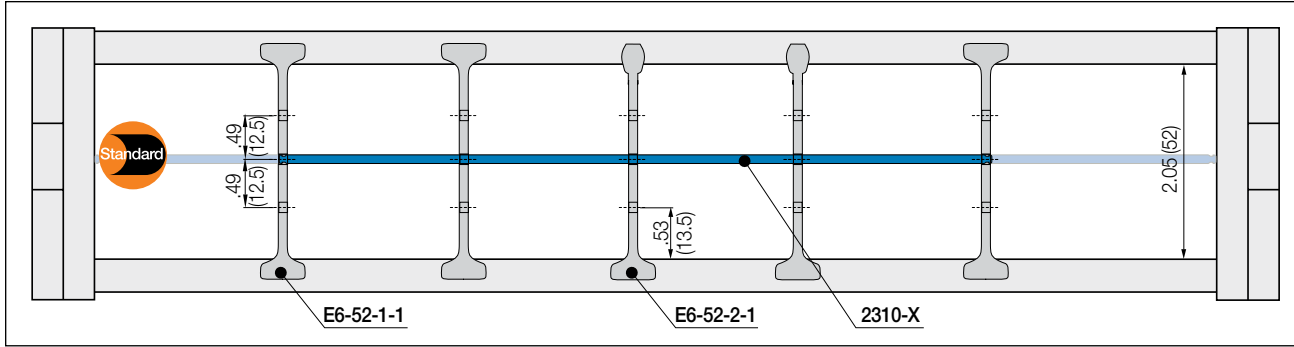

Note: Please maintain a lateral spacing of .51" (13 mm) between the separators and the side links. In the standard configuration separators are assembled every 2nd e-chain® link

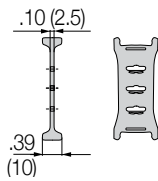

Separator, wide base

Unassembled	Part No. E6-52-1
Assembled	Part No. E6-52-1-1

- **Standard separator E6-52-1 for all applications**

Separator with wide base for maximum locking strength and safe standing in e-chains®.

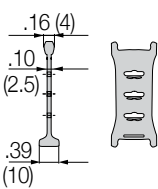

Separator, narrow head

Unassembled	Part No. E6-52-2
Assembled	Part No. E6-52-2-1

- **Separator E6-52-2 For even faster installation**

Firm hold to one side with a wide base, narrow on opposed side for easy cable assembly (slight grip)

Lockable full-width shelves - for the standard interior separation

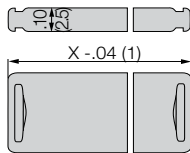

Full width shelf, lockable

Unassembled	Part No. 2300-X
Assembled	Part No. 2310-X

- **Full width shelf, lockable**

Shelf locks safely into separators on both ends, fixed width possible. Separators can be moved freely over the shelf in horizontal direction. Can be arranged at 3 different heights.

Width X in. (mm)	Part No. Unassembled	Part No. Assembled	Width X in. (mm)	Part No. Unassembled	Part No. Assembled	Width X in. (mm)	Part No. Unassembled	Part No. Assembled
0.59 (015)	2300-015	2310-015	2.36 (060)	2300-060	2310-060	3.43 (087)	2300-087	2310-087
0.98 (025)	2300-025	2310-025	2.44 (062)	2300-062	2310-062	3.54 (090)	2300-090	2310-090
1.18 (030)	2300-030	2310-030	2.56 (065)	2300-065	2310-065	3.94 (100)	2300-100	2310-100
1.50 (038)	2300-038	2310-038	2.76 (070)	2300-070	2310-070	4.06 (103)	2300-103	2310-103
1.57 (040)	2300-040	2310-040	2.95 (075)	2300-075	2310-075	4.33 (110)	2300-110	2310-110
1.97 (050)	2300-050	2310-050	3.03 (077)	2300-077	2310-077	4.72 (120)	2300-120	2310-120
2.24 (057)	2300-057	2310-057	3.15 (080)	2300-080	2310-080	4.92 (125)	2300-125	2310-125





matix 100ar/2

12
16.28.01.055

16.28.01.055

12

16.28.01.055

CAPE-A.06.0

CAPE-A.06.0

16.28.01.055

12

16.28.01.055



igus[®]
System E6

E6 - 6-piece e-chains® - Extremely low- noise, minimum vibrations

The E6 Series offers numerous advantages in addition to long life cycles. It provides extremely quiet, low-vibration operation. It minimizes the polygon effect which can occur during the rolling motion of an e-chain®. The ultra-low noise levels have been confirmed in a recent report by the Rheinland Technical Inspection Agency. Our extensive delivery program offers the right chain size for any application; a wide range of interior separators are also available. The same applies to the mounting brackets. .

Typical industries and applications

- Cleanroom
- Printing machines
- Handling & robot
- Machine Tools
- Measuring machines
- Semiconductor industries
- Medical industries
- Electronic industries
- General machinery



System E6 - Extremely
low noise - TÜV certified



System E6 -
6-piece link-design



LEVEL 1 absorption confirmed by IPA-Fraunhofer-
Institut according to SEMI E78-0998 for the E6 standard
material. Continuously constant conductance value as
there are no pin-bore connection (no air gaps).

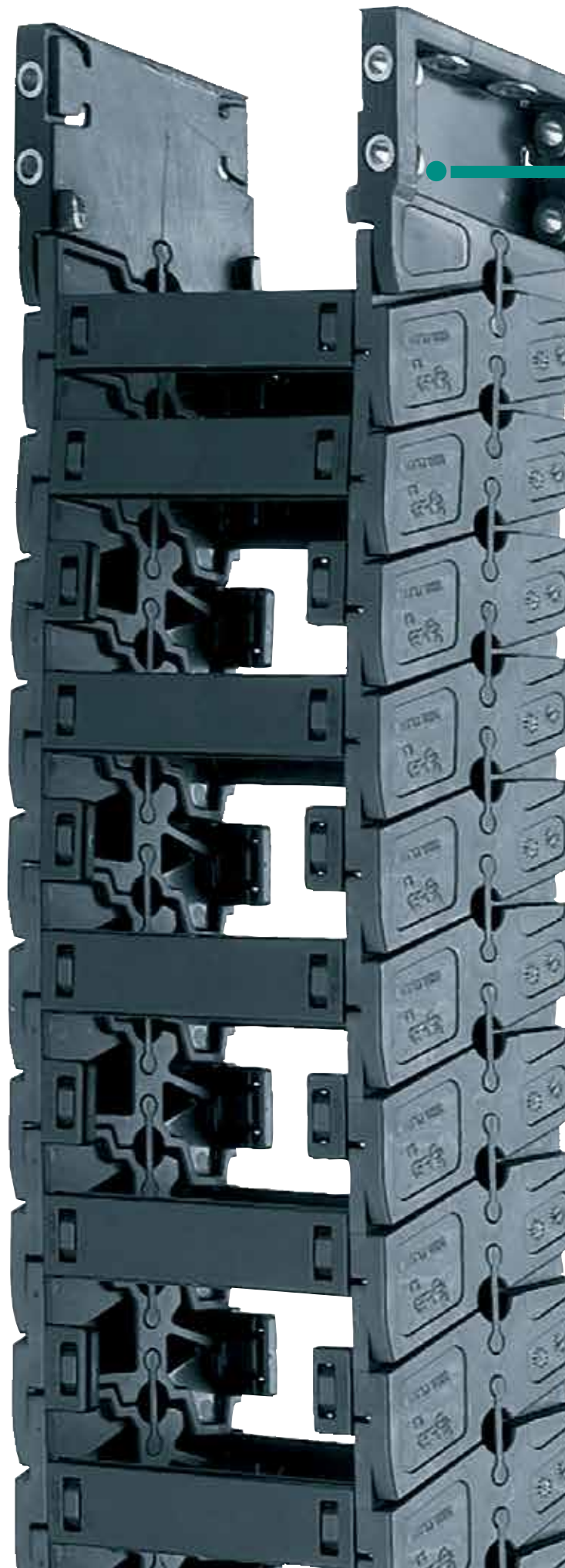



A linear drive provides for highly dynamic feed of PCBs. This system is twice as fast as handling units with a toothed-belt drive; designed to withstand high dynamic loads, the E6 e-chains® ensure a supply of power, coolant and control data with ultra-low noise and vibration

Selected noise tests - External noise corrected measurement values

e-chain® Series	Averaging of the corrected sound pressure levels	Test method
igus® Series E6-29*	≈ 37 dB(A)	unsupported v = 3.28 ft/s (1.0 m/s)
igus® Series E6-52*	≈ 41 dB(A)	unsupported, side mounted v = 1.64 ft/s (0.5 m/s)
igus® Series E6-52	≈ 46 dB(A)	unsupported v = 6.56 ft/s (2.0 m/s)
Chain 1 Third-party product	≈ 77 dB(A)	unsupported v = 6.56 ft/s (2.0 m/s)
Chain 2 Third-party product	≈ 68 dB(A)	unsupported v = 6.56 ft/s (2.0 m/s)
Chain 3 Third-party product	≈ 73 dB(A)	unsupported v = 6.56 ft/s (2.0 m/s)

Source: TÜV Rheinland *Source: igus® laboratory



Noise level ≤ 46 dB(A)

A measurement conducted by the Rhineland Technical Inspection Authority (TÜV Rheinland) in May 2002 indicates a value of ≤ 46 dB(A) at 6.56 ft/s (2 m/s) and with an unsupported length of 4..92 ft (1.5 m) with **Series E6-52-100-100-0**, and all this with at least 10 dB(A) sound pressure level generated by external noise. **We have received an official noise certificate from the Rhineland Technical Inspection Authority (TÜV Rheinland Berlin Brandenburg) and we are happy to provide you with a copy upon request.**

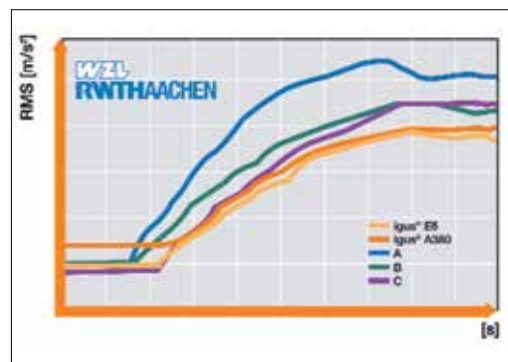

Study of the Laboratory of Machine Tools and Production Engineering (WZL) of the RWTH Aachen on "Vibration tests in energy supply chains".

Result: The E6 energy supply system of the company of igus® GmbH, Cologne, is characterized by extreme low vibration and smooth running.

e-chain system® E6 Selection Guide

Crossbars every 2nd link for almost all applications - Standard



Series	Inner height <i>hi</i> in. (mm)	Inner width <i>Bi</i> in. (mm)	Outer width <i>Ba</i> in. (mm)	Outer height <i>ha</i> in. (mm)	Bending radius <i>R</i> in. (mm)
E6-29	1.14 (29)	1.18-5.51 (30-140)	1.81-5.35 (46-136)	1.38 (35)	2.17-5.91 (55-150)
E6-35	1.38 (35)	1.18-5.51 (30-140)	1.97-6.30 (50-160)	1.65 (42)	2.17-5.91 (55-100)
E6-40	1.57 (40)	1.57-11.81 (40-300)	2.36-12.60 (60-320)	2.12 (54)	2.48-7.87 (63-200)
E6-52	2.05 (52)	1.57-11.81 (40-300)	2.52-12.76 (64-324)	2.56 (65)	2.95-9.84 (75-250)
E6-62	2.44 (62)	1.97-15.75 (50-400)	3.39-17.17 (86-436)	3.31 (84)	4.53-13.78 (115-350)
E6-80L	3.15 (80)	3.53-21.65 (87-550)	4.53-22.76 (115-578)	4.25 (108)	5.91-11.81 (150-300)
E6-80	3.15 (80)	1.97-23.62 (50-600)	3.94-25.59 (100-650)	4.25 (108)	5.91-17.72 (150-450)

E-Tubes fully enclosed, for complete cable protection



Series	Inner height <i>hi</i> in. (mm)	Inner width <i>Bi</i> in. (mm)	Outer width <i>Ba</i> in. (mm)	Outer height <i>ha</i> in. (mm)	Bending radius <i>R</i> in. (mm)
R6-29	1.10 (28)	1.18-4.72 (30-120)	1.81-5.35 (46-136)	1.38 (35)	2.17-5.91 (55-150)
R6-40	1.57 (40)	2.44-2.95 (62-75)	3.23-3.74 (82-95)	2.12 (54)	2.48-7.87 (63-200)
R6-52	2.05 (52)	1.97-6.89 (50-175)	2.91-7.83 (74-199)	2.56 (65)	2.95-9.84 (75-250)

Cleanroom qualification of E6 e-chains®



In many applications where cumbersome special solutions are used, a simple standard e-chain® can be used instead. A comprehensive test program was devised and performed for both gliding use and unsupported use. For many applications, the e-chains® in special materials are practically abrasion-free. Detailed tests results are available upon request. IPA tests confirm that standard igus® e-chains® meet cleanroom requirements. "Tested and certified as very good!" In cleanrooms a very high resistance to wear of moving parts is required. Therefore, e-chains® must be very resistant to wear. In order to meet the standard requirements for such a sensitive environment.

By eliminating the pin/bore connection, the unsupported E6 has very low abrasion and is suitable for cleanrooms



IPA classification - Report IG0704-400:

- Special material "cleanroom" - **Class 1 according to standard DIN EN ISO 14644-1** - Note: None of the classes corresponding to the DIN EN ISO 14644-1 Class 1 is included in the US standard at $v = (0.5 \text{ m/s})$, $a = (1.0 \text{ m/s}^2)$ - Series E6-29-060-150-0-CR
- Standard material - **Class 3 according to standard DIN EN ISO 14644-1** (according to US Fed. Stand. 209E, Class 1) at $v = (0.5 \text{ m/s})$, $a = (1.0 \text{ m/s}^2)$ Series E6-29-060-150-0 and $v = 1 \text{ m/s}$, $a = 2 \text{ m/s}^2$ Series E6-29-050-055-0 with inserted cables CF34-15-04, CF9-05-12, CF11-02-01-02-PBA-LC-D



Available from stock. Orders ship as early as today.*

*On average 90% of orders ship the same day..

e-chain system® E6 Assembly Instructions

System E6 e-chains® - Assembling



1 Position side links ...



2 ... gently twist and snap in



3 Gently insert connector by using a hammer



4 Position crossbars.
Push down and snap in

E-Tubes - Assembling Lids



1 Insert lid ...



2 ... push down and snap in



1 Lever with screwdriver ...



2 ... and remove lids by hand

System E6 e-chains® - Separating



1 Lever crossbars with screwdriver



2 Tap gently to remove connectors



3 Twist and ...



4 ... separate side links

Price Index

Series E6-29
Special Features / Options

Extremely low noise
 Test results upon request

IPA Certificate: Class 1, according to standard DIN EN ISO 14644-1 for the E6 system (Series E6-29-060-150-0-CR, (v = 1.64 ft/s, a = 3.28 ft/s²))

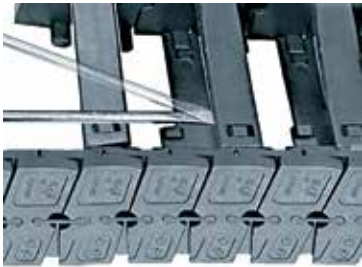
LEVEL 1 absorption confirmed by IPA-Fraunhofer-Institute according to SEMI E78-0998 for the E6 standard material
Assembly Tips

To close, push and click shut

Other Installation Methods

Vertical, hanging ≤ 98.4 ft (30 m)

Vertical, standing ≤ 6.56 ft (2 m)

Side-mounted, un supp. =

possible to a limited extent

Unsupported length of upper run upon request

Usage Guidelines



- If a low-noise version is required
- For very high speeds and/or accelerations
- If large stresses and thrust forces are present
- For small bending radii
- If less vibration is required
- Minimal abrasion, suitable for cleanrooms



- For side-mounted applications
 - **Series 2400/2500 E2/000**
- For RBR (reverse bending radii)
 - **Series 2400/2500 E2/000**
- For high additional loads
 - **Series 2400/2500 E2/000**
- For very dirty environments
 - **Series R6-29**

Features & Benefits

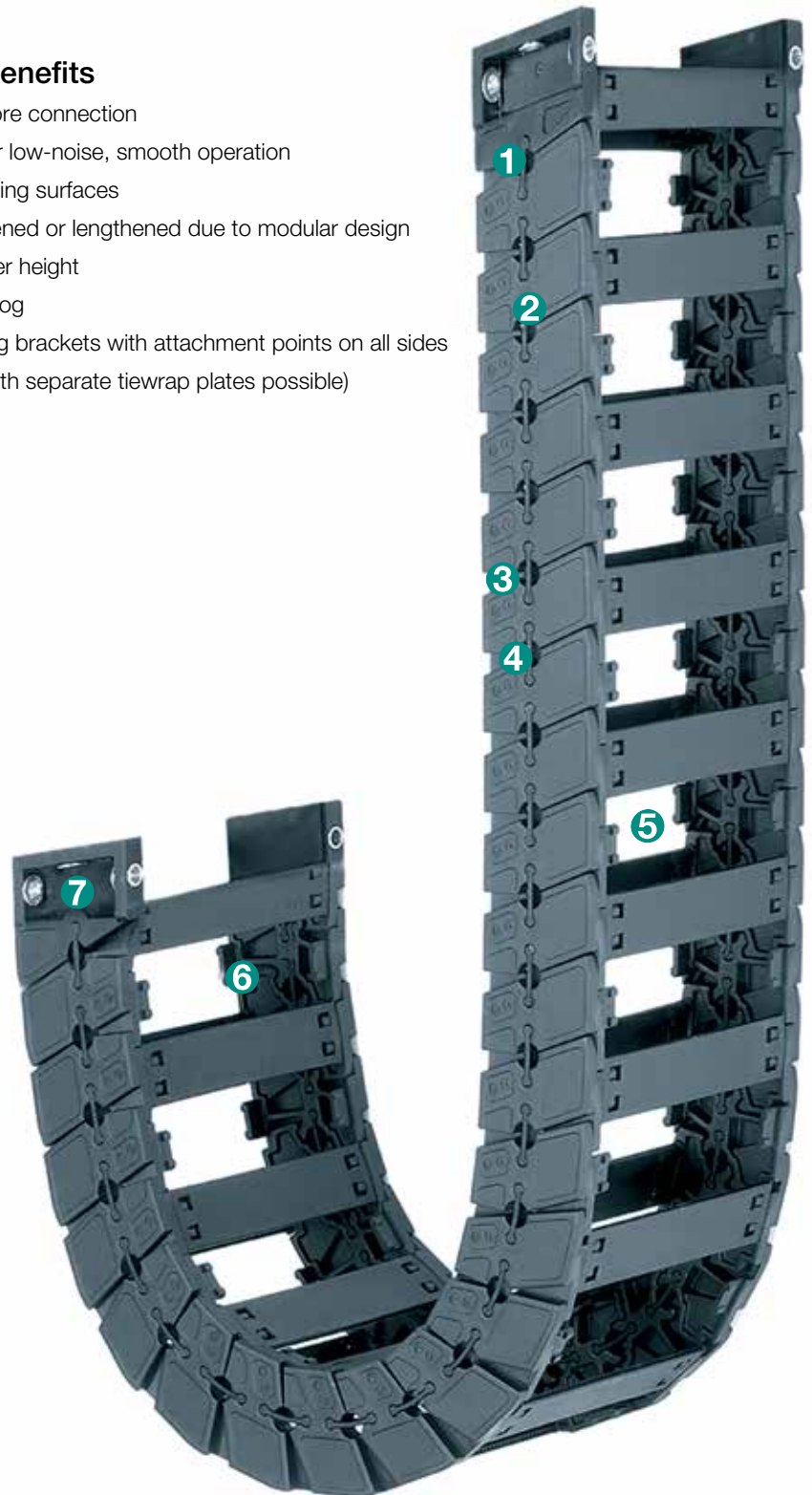
- 1 No pin and bore connection
- 2 Small pitch for low-noise, smooth operation
- 3 Very large gliding surfaces
- 4 Can be shortened or lengthened due to modular design
- 5 Increased inner height
- 6 Interior stop dog
- 7 KMA mounting brackets with attachment points on all sides (strain relief with separate tiwrap plates possible)

Order Example: Complete e-chain®

Please indicate chain length or number of links. Example:

 6.56 ft (2 m) **E6-29-100-075-0**

e-chain®

 With 2 separators **E6-29-11** assembled every 2nd link

Interior Separation

 1 Set **E6-290-100-12**

Mounting Bracket

e-chain system® E6

Series E6-29

Installation Dimensions



E6-29

Short travel, unsupported length

- FL_B = unsupported with permitted sag
 - FL_G = unsupported with straight upper run
- Further information ► Design, Chapter 1

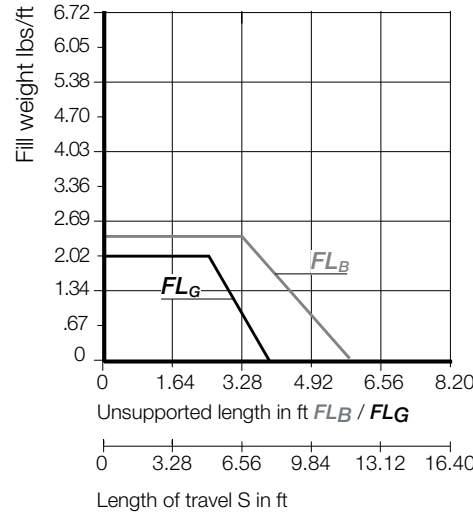
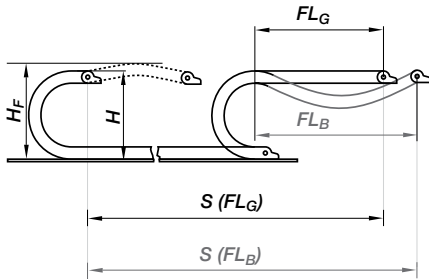

Short Travels - Unsupported



Unsupported e-chains® feature positive camber over short travels. This must be accounted for when specifying the clearance height. Please refer to **Installation dimensions** for further details.

Legend

- S = Length of travel
- R = Bending radius
- H = Nominal clearance height
- D = Overlength e-chain® radius in final position
- K = $\pi \cdot R$ + safety buffer
- H_f = Required clearance height

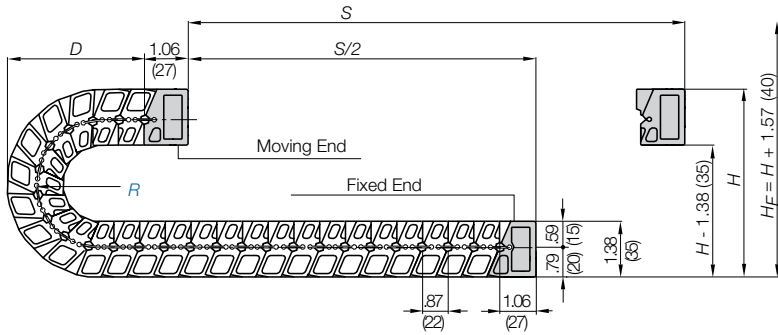

Pitch per link = .87" (22 mm)
 Links per ft (m) = 13.79 (46)
 For center mount applications:
 Chain length = $S/2 + K$

The required clearance height: $H_f = H + 1.57$ in. (40 mm) (with 1.34 lbs/ft (2.0 kg/m) fill weight). Please consult igus® if space is particularly restricted.

R	2.17 (055)	2.95 (075)	3.94 (100)	5.91 (150)
H	7.09 (180)	8.66 (220)	10.63 (270)	14.57 (370)
D	4.25 (108)	5.04 (128)	6.02 (153)	7.99 (203)
K	8.66 (220)	11.02 (280)	14.17 (360)	20.47 (520)

Speed / acceleration FL_G	max. 65.6 ft/s (20 m/s) / max. 656 ft/s ² (200 m/s ²)
Speed / acceleration FL_B	max. 9.84 ft/s (3 m/s) / max. 19.69 ft/s ² (6 m/s ²)
Gliding speed / acceleration (maximum)	upon request
Permitted temperature	-40°F (-40°C) up to +158°F (+70° C)
Flammability Class	VDE 0304 IIC UL94 HB

Technical Data



Details of material properties

► Design, Chapter 1

1.14

PDF: igus.com/e-chain-pdfs
 Product information: igus.com/e-chains



7.72

Series E6-29 - e-chain® with crossbars every link

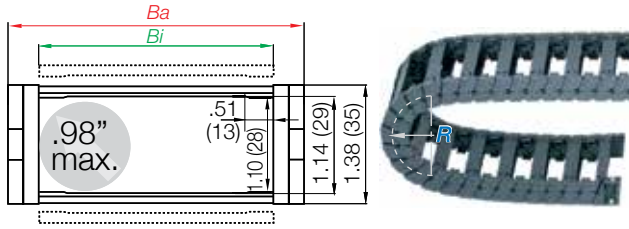

Part Number Structure

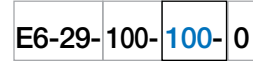

- Color - Black
- Bending radius
- Width
- Series

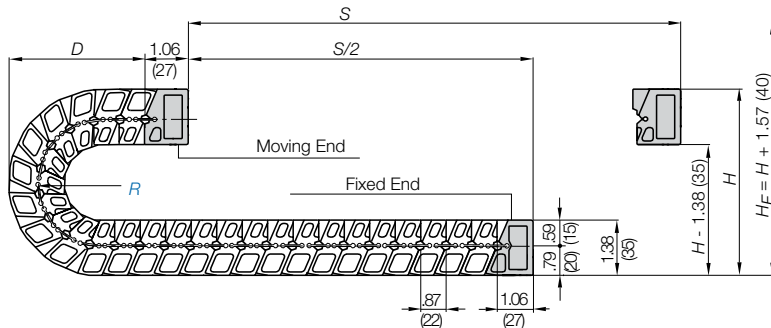

Supplement part number with required radius. Example: E6-29-100--0
Pitch: .87 in. (22 mm) per link links/ft (m) = 13.79 (46)

Part Number	Bi in. (mm)	Ba in. (mm)	Weight lbs/ft (kg/m)
E6-29-030- <input type="text"/> -0	1.18 (30)	1.81 (46)	≈ 0.49 (0.73)
E6-29-040- <input type="text"/> -0	1.57 (40)	2.20 (56)	≈ 0.50 (0.75)
E6-29-050- <input type="text"/> -0	1.97 (50)	2.60 (66)	≈ 0.52 (0.78)
E6-29-060- <input type="text"/> -0	2.36 (60)	2.99 (76)	≈ 0.54 (0.80)
E6-29-070- <input type="text"/> -0	2.76 (70)	3.39 (86)	≈ 0.56 (0.83)
E6-29-080- <input type="text"/> -0	3.15 (80)	3.78 (96)	≈ 0.57 (0.85)
E6-29-090- <input type="text"/> -0	3.54 (90)	4.17 (106)	≈ 0.59 (0.88)
E6-29-100- <input type="text"/> -0	3.94 (100)	4.57 (116)	≈ 0.60 (0.90)
E6-29-110- <input type="text"/> -0	4.33 (110)	4.96 (126)	≈ 0.62 (0.93)
E6-29-120- <input type="text"/> -0	4.72 (120)	5.35 (136)	≈ 0.64 (0.95)
E6-29-140- <input type="text"/> -0	5.51 (140)	6.14 (156)	≈ 0.67 (1.00)

Choose from the radii below for all of the above sizes
Radius (mm) Example: E6-29-100--0

	055	075	100	150
R	2.17 (055)	2.95 (075)	3.94 (100)	5.91 (150)
H	7.09 (180)	8.66 (220)	10.63 (270)	14.57 (370)
D	4.25 (108)	5.04 (128)	6.02 (153)	7.99 (203)
K	8.66 (220)	11.02 (280)	14.17 (360)	20.47 (520)

e-chain® as separate parts, links and side plates

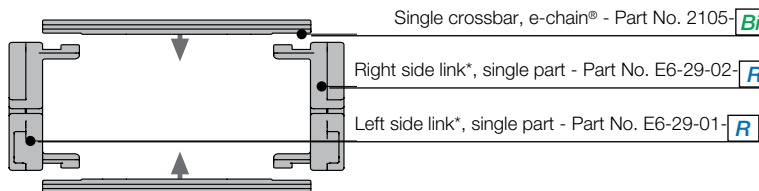

Polymer spring as single part -
Part No. E6-29-140

*View from the fixed point of the e-chain®/E-Tube

e-chain system® E6
Series E6-29
Interior Separation - New Generation



E6-29

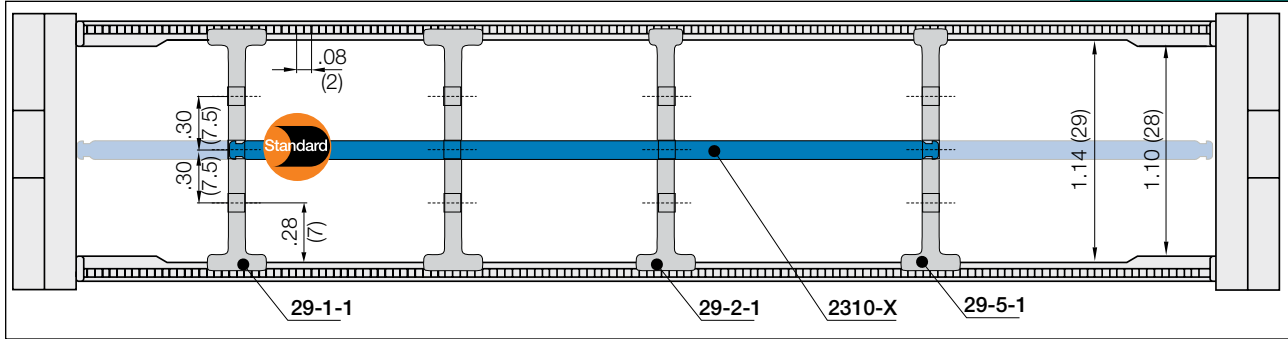

 **Note:** Please maintain a lateral spacing of .51" (13 mm) between the separators and the side links. In the standard configuration separators are assembled every 2nd e-chain® link

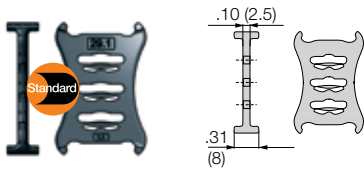

Separator, wide base

Unassembled	Part No. 29-1
Assembled	Part No. 29-1-1

• **Standard separator 29-1 for all applications**

Separator with wide base for maximum locking strength and safe standing in e-chains®.

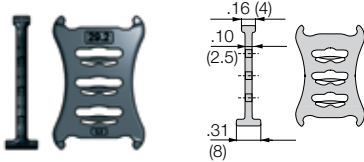

Separator, narrow head

Unassembled	Part No. 29-2
Assembled	Part No. 29-2-1

• **Separator 29-2**

For even faster installation

is used when vertical and horizontal separation is required. Due to its slot, it allows basic vertical/horizontal shelving arrangements.

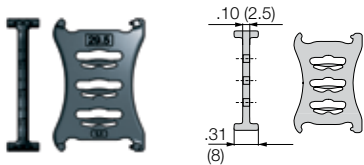

Notch separator, for notch crossbar

Unassembled	Part No. 29-5
Assembled	Part No. 29-5-1

• **Separator 29-5**

Locks safely in .08 (2 mm) increments

For exact positioning in e-chains®. Recommended for side-mounted applications.

Lockable full-width shelves - for the standard interior separation

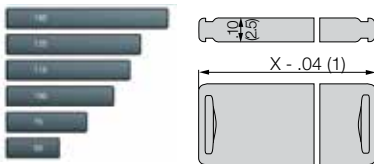

Full width shelf, lockable

Unassembled	Part No. 2300-X
Assembled	Part No. 2310-X

• **Full width shelf, lockable**

is used when vertical and horizontal separation is required. Due to its slot, it allows basic vertical/horizontal shelving arrangements.

Width X in. (mm)	Part No. Unassembled	Part No. Assembled	Width X in. (mm)	Part No. Unassembled	Part No. Assembled	Width X in. (mm)	Part No. Unassembled	Part No. Assembled
0.59 (015)	2300-15	2310-15	2.36 (060)	2300-60	2310-60	3.43 (087)	2300-87	2310-87
0.98 (025)	2300-25	2310-25	2.44 (062)	2300-62	2310-62	3.54 (090)	2300-90	2310-90
1.18 (030)	2300-30	2310-30	2.56 (065)	2300-65	2310-65	3.94 (100)	2300-100	2310-100
1.50 (038)	2300-38	2310-38	2.76 (070)	2300-70	2310-70	4.06 (103)	2300-103	2310-103
1.57 (040)	2300-40	2310-40	2.95 (075)	2300-75	2310-75	4.33 (110)	2300-110	2310-110
1.97 (050)	2300-50	2310-50	3.03 (077)	2300-77	2310-77	4.72 (120)	2300-120	2310-120
2.24 (057)	2300-57	2310-57	3.15 (080)	2300-80	2310-80	4.92 (125)	2300-125	2310-125

Separator with integrated strain relief

Strain relief separator Part No. E6-29-02-Z can be integrated into the mounting bracket and can be placed there at any point of the e-chain®. It combines strain relief and interior separation, it can be installed on the first or last e-chain® link and is easy to assemble without any screws.

For more information ► Chapter 10, Strain Relief



PDF: igus.com/e-chain-pdfs
Product information: igus.com/e-chains



Vertical separators

Vertical separators are used if a vertical subdivision of the e-chain® interior is re-quired. By standard, vertical separators are assembled every other e-chain® link.

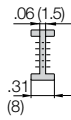
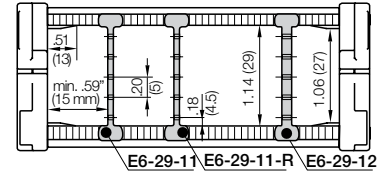

Vertical Separator

Unassembled	E6-29-01
Assembled	E6-29-11

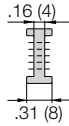

Vertical Separator

Unassembled	E6-29-02
Assembled	E6-29-12

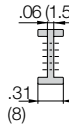

Vertical Separator

Unassembled	E6-29-01R
Assembled	E6-29-11R

• **Slotted vertical separator E6-29-01**

This separator is used for general subdivision of e-chains®. Can be used in combination with full-width shelf 111-X

• **Vertical separator E6-29-02**

For use with side plate E6-29-13, full-width shelf 221-X and shelf 2210-X

• **Locking separator E6-29-01R**

Can be locked onto crossbars in .08" (2mm) increments. For side-mounted applications use with full-width shelf 111-X

Full-width shelf

For applications involving many thin cables with similar or identical diameters.

Full-width shelf **111-X** can be used with vertical separator **E6-29-11** and locking separator **E6-29-11-R**.

Full-width shelf **221-X** can be used with vertical separator **E6-29-12**, side plate **E6-29-13**

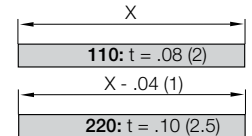
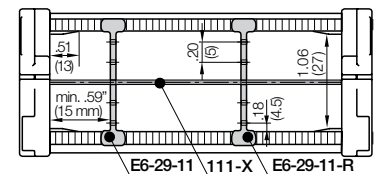

Shelves 110-X/220-XX

Shelves can be inserted at 5 different heights in .20" (5mm) increments

Width X in. (mm)	Part No.		Part No.		Width X in. (mm)	Part No.		Part No.	
	Unassembled	Assembled	Unassembled	Assembled		Unassembled	Assembled	Unassembled	Assembled
1.18 (030)	110-30	220-30	111-30	221-30	3.15 (080)	110-80	220-80	111-80	221-80
1.57 (040)	110-40	220-40	111-40	221-40	3.54 (090)	110-90	220-90	111-90	221-90
1.97 (050)	110-50	220-50	111-50	221-50	3.94 (100)	110-100	220-100	111-100	221-100
2.36 (060)	110-60	220-60	111-60	221-60	4.33 (110)	110-110	220-110	111-110	221-110
2.76 (070)	110-70	220-70	111-70	221-70	4.72 (120)	110-120	220-120	111-120	221-120

Shelves

These components form the basic pattern of a shelf system.

Shelves of various widths can be arranged at 5 different heights in .20" (5mm) increments

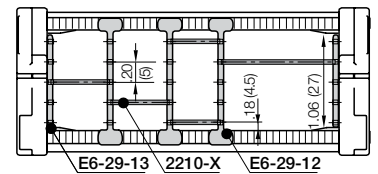

Shelves 2200-XX

Shelf **2210-X** can be used with vertical separator **E6-29-12** and side plate **E6-29-13**

Width X in. (mm)	Part No.		Width X in. (mm)	Part No.	
	Unassembled	Assembled		Unassembled	Assembled
.71 (18)	2200-18	2210-18	1.89 (48)	2200-48	2210-48
.91 (23)	2200-23	2210-23	2.28 (58)	2200-58	2210-58
1.10 (28)	2200-28	2210-28	2.68 (68)	2200-68	2210-68
1.30 (33)	2200-33	2210-33	2.87 (73)	2200-73	2210-73
1.50 (38)	2200-38	2210-38	3.46 (88)	2200-88	2210-88
1.69 (43)	2200-43	2210-43	3.90 (99)	2200-99	2210-99

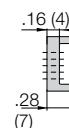

Slotted Separator

Unassembled	E6-29-03
Assembled	E6-29-13

- **Side plate, slotted**
 This separator is used for general subdivision of e-chains®.

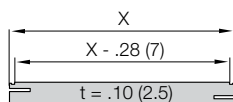

KMA - Pivoting



- Bolted connection outside of the chain cross-section
- Recommended for unsupported applications (for gliding applications please contact igus®)
- Confined installation conditions
- Attachment capability on all sides

Moving end
E6-290...2

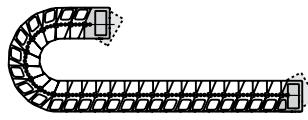

Fixed end
E6-290...1

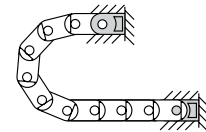

Possible installation configurations -

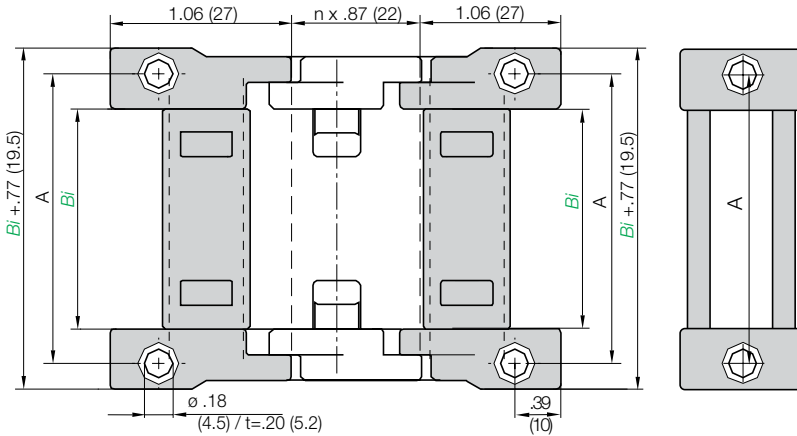

Part Number Structure

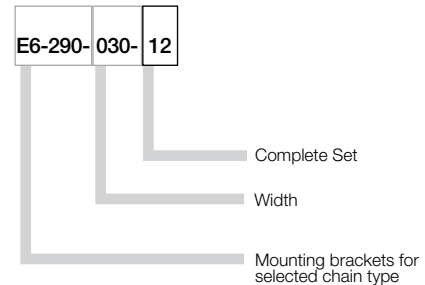

Full set, for both ends:

E6-290-030-12 Full set, both fixed and moving end

Single-part order:

E6-290-030-1 Mounting bracket fixed end

E6-290-030-2 Mounting bracket moving end

For Series	Part No. Full Set	Dimension A in. (mm)	For Series	Part No. Full Set	Dimension A in. (mm)
E6-29-030	E6-290-030-12	1.57 (40)	E6-29-090	E6-290-090-12	3.94 (100)
E6-29-040	E6-290-040-12	1.97 (50)	E6-29-100	E6-290-100-12	4.33 (110)
E6-29-050	E6-290-050-12	2.36 (60)	E6-29-110	E6-290-110-12	4.72 (120)
E6-29-060	E6-290-060-12	2.76 (70)	E6-29-120	E6-290-120-12	5.12 (130)
E6-29-070	E6-290-070-12	3.15 (80)	E6-29-140	E6-290-140-12	5.91 (150)
E6-29-080	E6-290-080-12	3.54 (90)			

Tiewrap Plates



Tiewrap plates as an individual part

Tiewrap Plates	n Number of Teeth	Dimension C	Dimension B
2020-ZB	3	1.18 (30)	.59 (15)
2030-ZB	4	1.57 (40)	.79 (20)
2040-ZB	5	1.97 (50)	1.18 (30)
2050-ZB	6	2.36 (60)	1.57 (40)
2070-ZB	8	3.15 (80)	2.36 (60)
2090-ZB	9	3.54 (90)	2.76 (70)
2100-ZB	10	3.94 (100)	3.15 (80)
2120-ZB	12	4.72 (120)	3.94 (100)

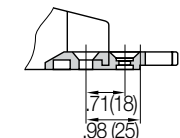

Shown assembled

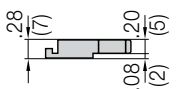

Single tiewrap plate

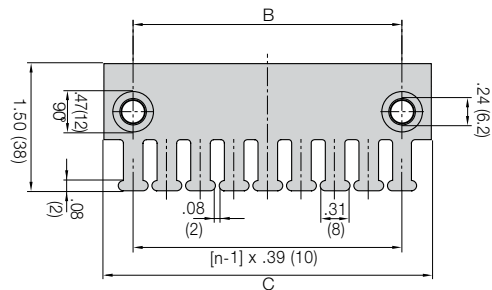

If used with KMA brackets with profile rail please add "KMA" to the end of the part number.

Example: 2020-ZBKMA

- Other strain relief elements
- Strain Relief, Chapter 10



Price Index



Series R6-29

Special Features / Options



Extremely low noise
Test results upon request



IPA Certificate: Class 1, according to standard DIN EN ISO 14644-1 for the E6 system (Series E6-29-060-150-0-CR, (v = 1.64 ft/s, a = 3.28 ft/s²))



LEVEL 1 absorption confirmed by IPA-Fraunhofer-Institute according to SEMI E78-0998 for the E6 standard material

Assembly Tips



Lever and remove lids

Other Installation Methods

Vertical, hanging ≤ 98.4 ft (30 m)

Vertical, standing ≤ 6.56 ft (2 m)

Side-mounted, un supp. = possible to a limited extent

Unsupported length of upper run upon request

Usage Guidelines



- If a low-noise version is required
- For very high speeds and/or accelerations
- Protection against dirt and chips
- For small bending radii
- If less vibration is required
- Minimal abrasion, suitable for cleanrooms



- For side-mounted applications
 - **Series 2480 E2 Tubes**
- For RBR (reverse bending radii)
 - **Series 2480 E2 Tubes**
- For high additional loads
 - **Series 2480 E2 Tubes**

Features & Benefits

- 1 Fully enclosed E-Tube
- 2 No pin and bore connection
- 3 Interior stop dog
- 4 Very large gliding surfaces
- 5 KMA mounting brackets with attachment points on all sides (strain relief with separate tie-wrap plates possible)
- 6 Can be shortened or lengthened due to modular design
- 7 Small pitch for low-noise, smooth operation



Order Example: Complete e-chain®

Please indicate chain length or number of links. Example:

6.56 ft (2 m) **R6-29-080-100-0****E-Tube**With 2 separators **R6-29-11** assembled every 2nd link**Interior Separation**1 Set **R6-290-080-12****Mounting Bracket**

e-chain system® E6

Series R6-29

Installation Dimensions



R6-29

Short travel, unsupported length

- FL_B = unsupported with permitted sag
 - FL_G = unsupported with straight upper run
- Further information ► Design, Chapter 1

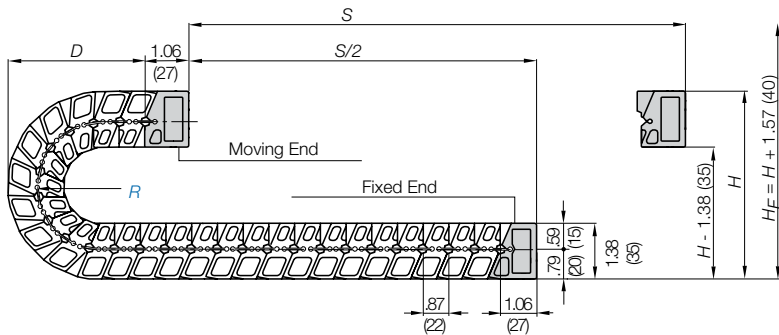
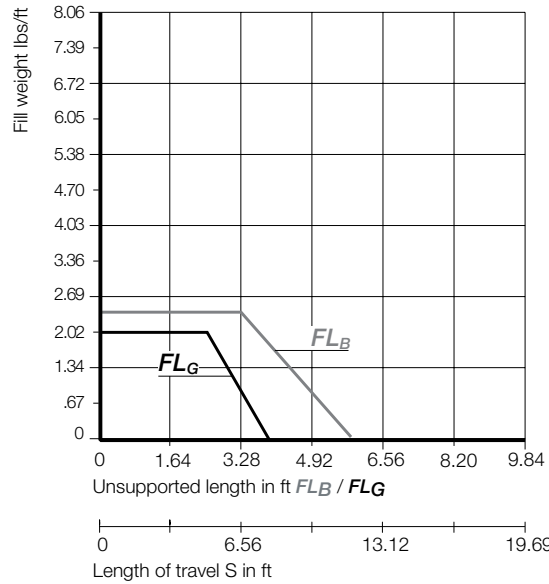
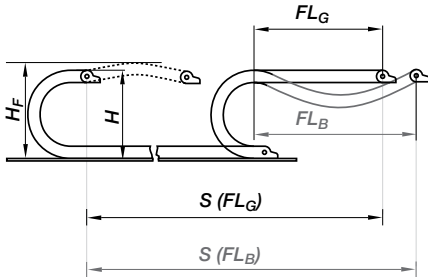

Pitch per link = .87" (22 mm)
 Links per ft (m) = 13.79 (46)
 For center mount applications:
 Chain length = $\frac{S}{2} + K$

The required clearance height: $H_F = H + 1.57$ in. (40 mm) (with 1.34 lbs/ft (2.0 kg/m) fill weight). Please consult igus® if space is particularly restricted.

R	2.17 (055)	2.95 (075)	3.94 (100)	5.91 (150)
H	7.09 (180)	8.66 (220)	10.63 (270)	14.57 (370)
D	4.25 (108)	5.04 (128)	6.02 (153)	7.99 (203)
K	8.66 (220)	11.02 (280)	14.17 (360)	20.47 (520)

Speed / acceleration FL_G	max. 65.6 ft/s (20 m/s) / max. 656 ft/s ² (200 m/s ²)
Speed / acceleration FL_B	max. 9.84 ft/s (3 m/s) / max. 19.69 ft/s ² (6 m/s ²)
Gliding speed / acceleration (maximum)	upon request
Permitted temperature	-40°F (-40°C) up to +158°F (+70° C)
Flammability Class	VDE 0304 IIC UL94 HB

Short Travels - Unsupported



Unsupported e-chains® feature positive camber over short travels. This must be accounted for when specifying the clearance height. Please refer to **Installation dimensions** for further details.

Legend

- S = Length of travel
- R = Bending radius
- H = Nominal clearance height
- D = Overlength e-chain® radius in final position
- $K = \pi \cdot R + \text{safety buffer}$
- H_F = Required clearance height

1.10

PDF: igus.com/e-chain-pdfs
 Product information: igus.com/e-chains



Technical Data



Details of material properties

► Design, Chapter 1

7.78

Series R6-29 - E-Tube, removable lids along the inner and outer radius

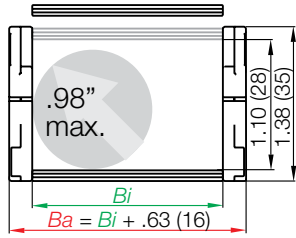

Part Number Structure

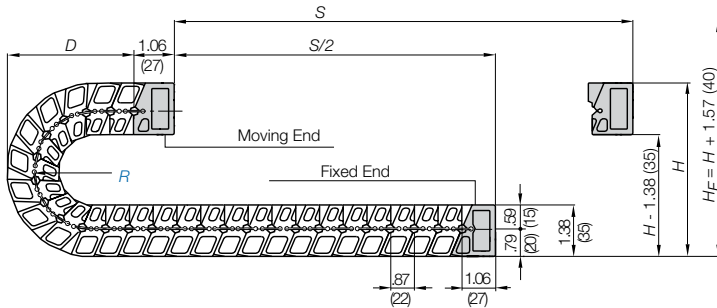
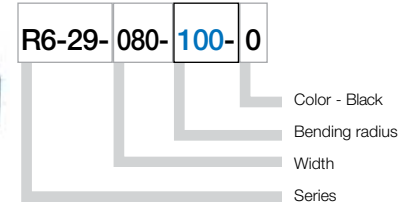

Supplement part number with required radius.

Example: R6-29-080-100-0

Pitch: .87 in. (22 mm) per link links/ft (m) = 13.79 (46)

Part Number	Bi in. (mm)	Ba in. (mm)	Weight lbs/ft (kg/m)
R6-29-030-□-0	1.18 (30)	1.81 (46)	≈ 0.54 (0.80)
R6-29-040-□-0	1.57 (40)	2.20 (56)	≈ 0.57 (0.85)
R6-29-050-□-0	1.97 (50)	2.60 (66)	≈ 0.60 (0.89)
R6-29-060-□-0	2.36 (60)	2.99 (76)	≈ 0.63 (0.94)
R6-29-080-□-0	3.15 (80)	3.78 (96)	≈ 0.69 (1.03)
R6-29-110-□-0	4.33 (110)	4.96 (126)	≈ 0.79 (1.18)
R6-29-120-□-0	4.72 (120)	5.35 (136)	≈ 0.82 (1.22)

Choose from the radii below for all of the above sizes
Radius (mm) Example: R6-29-080-100-0

	055	075	100	150
R	2.17 (055)	2.95 (075)	3.94 (100)	5.91 (150)
H	7.09 (180)	8.66 (220)	10.63 (270)	14.57 (370)
D	4.25 (108)	5.04 (128)	6.02 (153)	7.99 (203)
K	8.66 (220)	11.02 (280)	14.17 (360)	20.47 (520)

Vertical separators

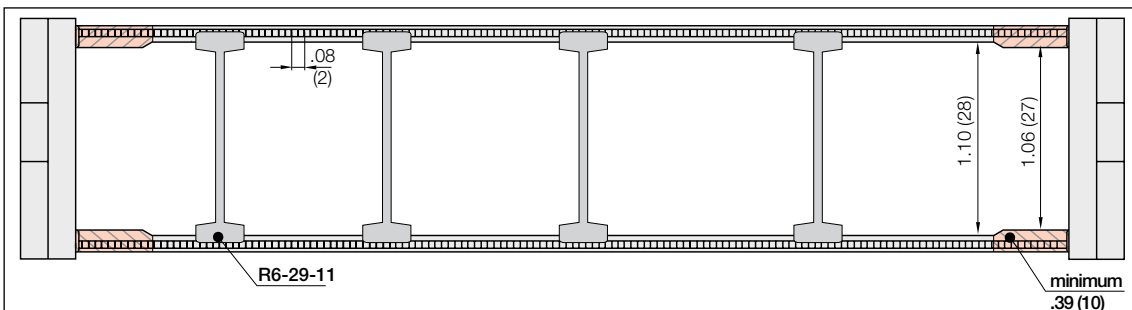

Note: Please maintain a lateral spacing of .39" (10 mm) between the separators and the side links. In the standard configuration separators are assembled every 2nd e-chain® link

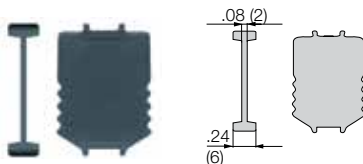

Separator for E-Tubes

Unassembled Part No. R6-29-01

Assembled Part No. R6-29-11

Vertical separator R6-29-01

This separator is used for general subdivision of E-Tubes. Separator snaps onto either the bottom of the carrier or the lid. Stays attached to that side. Opposite side can be removed.

e-chain system® E6

Series R6-29

Mounting Bracket - KMA / Strain Relief



R6-29



Option 1: KMA - Pivoting

- Bolted connection outside of the chain cross-section
- Recommended for unsupported applications (for gliding applications please contact igus®)
- Confined installation conditions
- Attachment capability on all sides

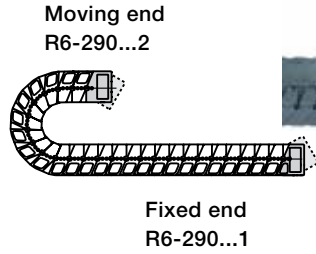

Possible installation configurations -

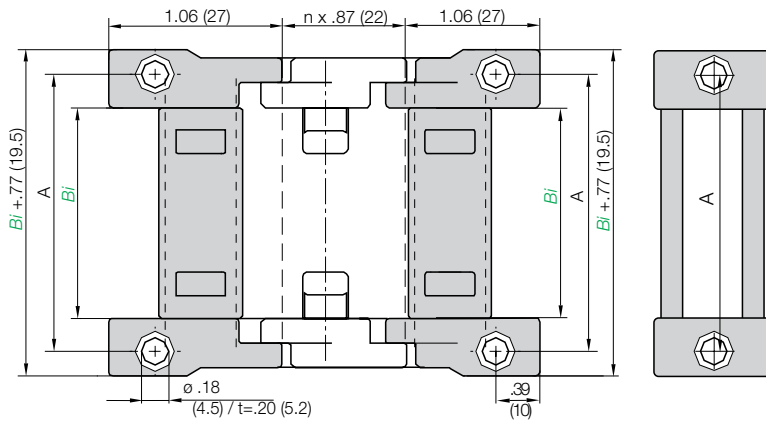

Part Number Structure

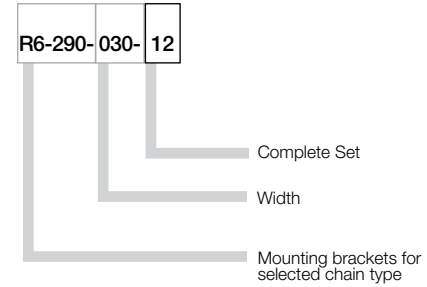

For Series	Part No. Full Set	Dimension A in. (mm)
R6-290-030	R6-290-030-12	1.57 (40)
R6-290-040	R6-290-040-12	1.97 (50)
R6-290-050	R6-290-050-12	2.36 (60)
R6-290-060	R6-290-060-12	2.76 (70)
R6-290-080	R6-290-080-12	3.54 (90)
R6-290-110	R6-290-110-12	4.72 (120)
R6-290-120	R6-290-120-12	5.12 (130)

Full set, for both ends:

R6-290-030-12 Full set, both fixed and moving end

Single-part order:

R6-290-025-1 Mounting bracket fixed end

R6-290-025-2 Mounting bracket moving end

Tiewrap Plates

Option 1: Tiewrap plates as an individual part

Available as an individual component, can be fixed onto a mounting bracket with the use of a profile rail.

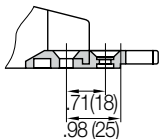

Shown assembled

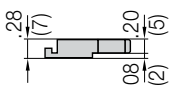

Single tiewrap plate

Tiewrap Plates	n Number of Teeth	Dimension C	Dimension B
2020-ZB	3	1.18 (30)	.59 (15)
2030-ZB	4	1.57 (40)	.79 (20)
2040-ZB	5	1.97 (50)	1.18 (30)
2050-ZB	6	2.36 (60)	1.57 (40)
2070-ZB	8	3.15 (80)	2.36 (60)
2090-ZB	9	3.54 (90)	2.76 (70)
2100-ZB	10	3.94 (100)	3.15 (80)
2120-ZB	12	4.72 (120)	3.94 (100)

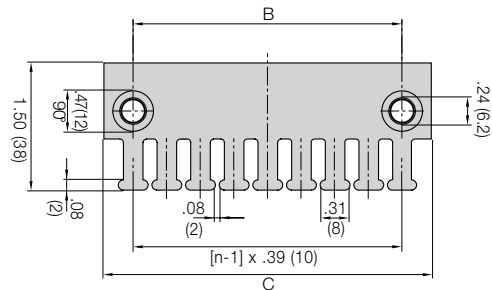

If used with KMA brackets with profile rail please add "KMA" to the end of the part number.

Example: 2020-ZBKMA

- Other strain relief elements
- Strain Relief, Chapter 10

PDF: igus.com/e-chain-pdfs
Product information: igus.com/e-chains



Price Index

Series E6-35
Special Features / Options

Extremely low noise
 Test results upon request

IPA Certificate: Class 1, according to standard DIN EN ISO 14644-1 for the E6 system (Series E6-29-060-150-0-CR, (v = 1.64 ft/s, a = 3.28 ft/s²))

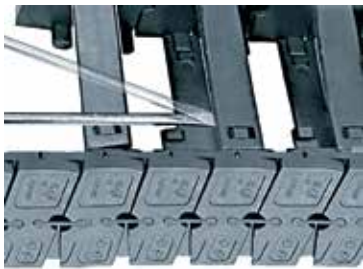
LEVEL 1 absorption confirmed by IPA-Fraunhofer-Institute according to SEMI E78-0998 for the E6 standard material
Assembly Tips

To close, push and click shut

Other Installation Methods

Vertical, hanging ≤ 98.4 ft (30 m)

Vertical, standing ≤ 6.56 ft (2 m)

Side-mounted, un_supp. = possible to a limited extent

Unsupported length of upper run upon request

Usage Guidelines



- If a low-noise version is required
- For very high speeds and/or accelerations
- If large stresses and thrust forces are present
- For small bending radii
- If less vibration is required
- Minimal abrasion, suitable for cleanrooms



- If a fully enclosed tube is required
 ► **Series 2680 E2/000**
- For side mounted applications
 ► **Series E4-32 E4-1**
- For RBR (Reverse Bending Radius)
 ► **Series E4-32 E4-1**
- For high additional loads
 ► **Series E4-32 E4-1**
- For dirty environments
 ► **Series E4-32 E4-1**

7.81
Features & Benefits

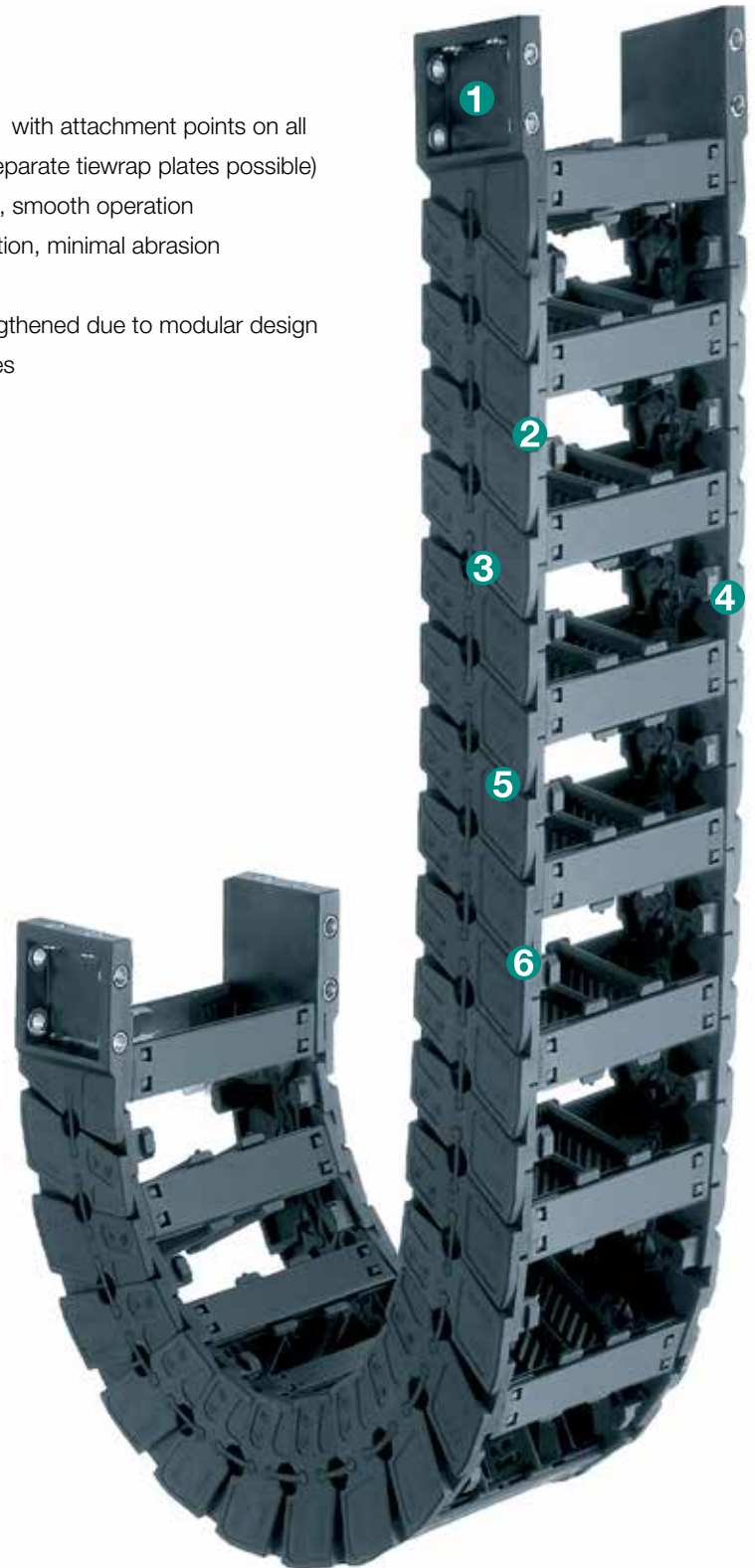
- 1 KMA mounting brackets with attachment points on all sides (strain relief with separate tie-wrap plates possible)
- 2 Small pitch for low-noise, smooth operation
- 3 No pin and bore connection, minimal abrasion
- 4 Interior stop dog
- 5 Can be shortened or lengthened due to modular design
- 6 Very large gliding surfaces

Order Example: Complete e-chain®

Please indicate chain length or number of links. Example:

 6.56 ft (2 m) **E6-35-100-055-0**

e-chain®

 With 2 separators **E6-35-11** assembled every 2nd link

Interior Separation

 1 Set **E6-350-100-12**

Mounting Bracket

e-chain system® E6

Series E6-35

Installation Dimensions



E6-35

Short travel, unsupported length

- FL_B = unsupported with permitted sag
 - FL_G = unsupported with straight upper run
- Further information ► Design, Chapter 1

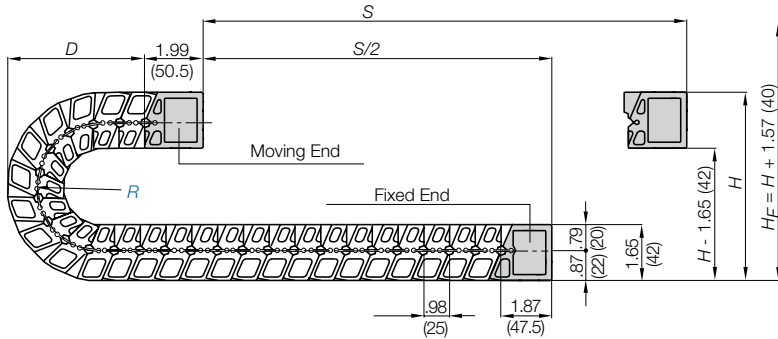
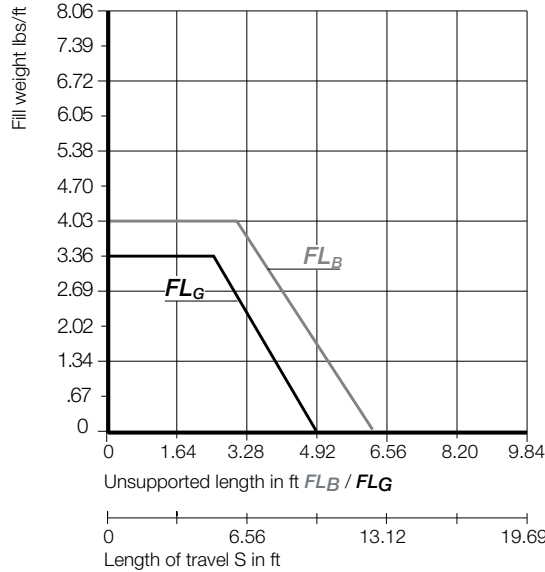
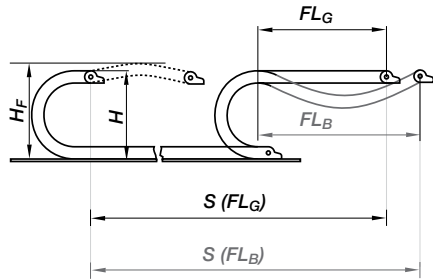

Pitch per link = .98" (25 mm)
 Links per ft (m) = 12.19 (40)
 For center mount applications:
 Chain length = $\frac{S}{2} + K$

The required clearance height: $H_f = H + 1.57$ in. (40 mm) (with 1.34 lbs/ft (2.0 kg/m) fill weight). Please consult igus® if space is particularly restricted.

R	2.17 (055)	2.95 (075)	3.94 (100)	5.91 (150)
H	7.44 (189)	9.01 (229)	10.98 (279)	14.92 (379)
D	4.53 (115)	5.31 (135)	6.30 (160)	8.27 (210)
K	8.86 (225)	11.42 (290)	14.37 (365)	20.67 (525)

Short Travels - Unsupported

1.38



Unsupported e-chains® feature positive camber over short travels. This must be accounted for when specifying the clearance height. Please refer to **Installation dimensions** for further details.

Legend

- S = Length of travel
- R = Bending radius
- H = Nominal clearance height
- D = Overlength e-chain® radius in final position
- $K = \pi \cdot R + \text{safety buffer}$
- H_f = Required clearance height

PDF: igus.com/e-chain-pdfs
 Product information: igus.com/e-chains



Speed / acceleration FL_G	max. 65.6 ft/s (20 m/s) / max. 656 ft/s² (200 m/s²)
Speed / acceleration FL_B	max. 9.84 ft/s (3 m/s) / max. 19.69 ft/s² (6 m/s²)
Gliding speed / acceleration (maximum)	upon request
Permitted temperature	-40°F (-40°C) up to +158°F (+70° C)
Flammability Class	VDE 0304 IIC UL94 HB

Technical Data



Details of material properties

► Design, Chapter 1

Series E6-35 - e-chain® with crossbars every other link

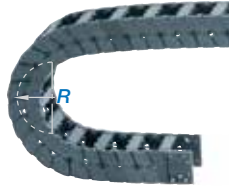
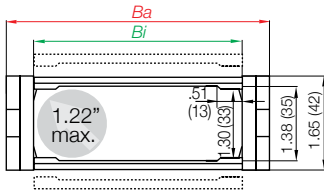

Part Number Structure

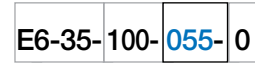

- Color - Black
- Bending radius
- Width
- Series

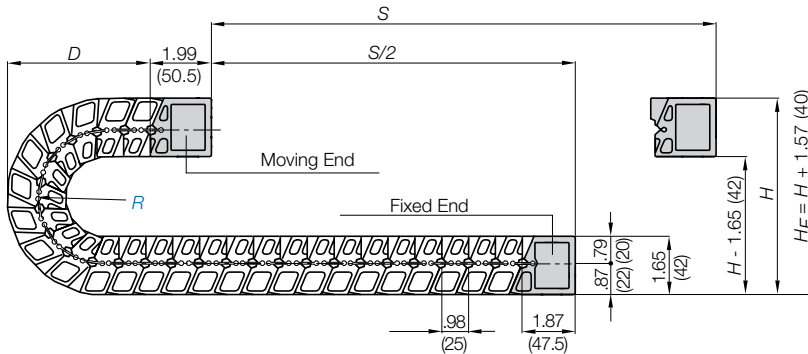

Supplement part number with required radius.
Example: E6-35-100-055-0
Pitch: .98 in. (25 mm) per link links/ft (m) = 12.19 (40)

Part Number	Bi in. (mm)	Ba in. (mm)	Weight lbs/ft (kg/m)
E6-35-030- <input type="checkbox"/> -0	1.18 (30)	1.97 (50)	≈ 0.59 (0.88)
E6-35-040- <input type="checkbox"/> -0	1.57 (40)	2.36 (60)	≈ 0.54 (0.90)
E6-35-050- <input type="checkbox"/> -0	1.97 (50)	2.76 (70)	≈ 0.90 (0.92)
E6-35-060- <input type="checkbox"/> -0	2.36 (60)	3.15 (80)	≈ 0.63 (0.94)
E6-35-070- <input type="checkbox"/> -0	2.76 (70)	3.54 (90)	≈ 0.65 (0.96)
E6-35-080- <input type="checkbox"/> -0	3.15 (80)	3.94 (100)	≈ 0.66 (0.99)
E6-35-090- <input type="checkbox"/> -0	3.54 (90)	4.33 (110)	≈ 0.68 (1.01)
E6-35-100- <input type="checkbox"/> -0	3.94 (100)	4.72 (120)	≈ 0.69 (1.03)
E6-35-110- <input type="checkbox"/> -0	4.33 (110)	5.12 (130)	≈ 0.76 (1.05)
E6-35-120- <input type="checkbox"/> -0	4.72 (120)	5.51 (140)	≈ 0.72 (1.07)
E6-35-140- <input type="checkbox"/> -0	5.51 (140)	6.30 (160)	≈ 0.75 (1.11)

Choose from the radii below for all of the above sizes
Radius (mm) Example: E6-35-100-055-0

	055	075	100	150
R	2.17 (055)	2.95 (075)	3.94 (100)	5.91 (150)
H	7.44 (189)	9.01 (229)	10.98 (279)	14.92 (379)
D	4.53 (115)	5.31 (135)	6.30 (160)	8.27 (210)
K	8.86 (225)	11.42 (290)	14.37 (365)	20.67 (525)

e-chain® as separate parts, links and side plates

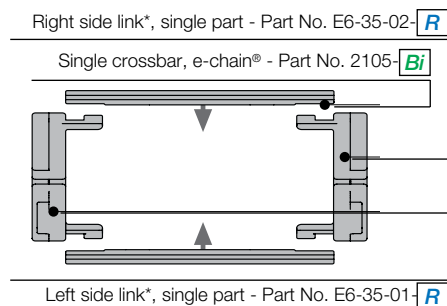

Polymer spring as single part -
Part No. E6-35-150

*View from the fixed point of the e-chain®/E-Tube

e-chain system® E6
Series E6-35
Interior Separation - New Generation



E6-35

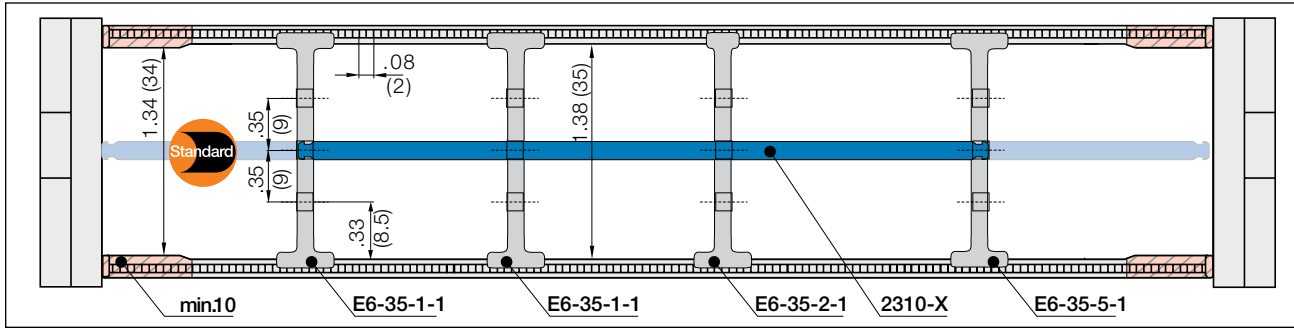

Note: Please maintain a lateral spacing of .39" (10 mm) between the separators and the side links. In the standard configuration separators are assembled every 2nd e-chain® link

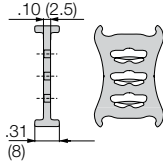

Separator, wide base

Unassembled	Part No. E6-35-1
Assembled	Part No. E6-35-1-1

- **Standard separator E6-35-1 for all applications**

Separator with wide base for maximum locking strength and safe standing in e-chains®.

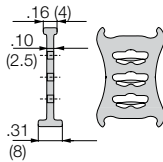

Separator, narrow head

Unassembled	Part No. E6-35-2
Assembled	Part No. E6-35-2-1

- **Separator E6-35-2 For even faster installation**

Firmly holds to one side with a wide base, narrow on opposite side for easy cable assembly (slight grip).

Lockable full-width shelves - for the standard interior separation

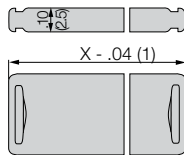

Full width shelf, lockable

Unassembled	Part No. 2300-X
Assembled	Part No. 2310-X

- **Full width shelf, lockable**

Shelf locks safely into separators on both ends, fixed width possible. Separators can be moved freely over the shelf horizontally. Can be arranged at three different heights.

Width X in. (mm)	Part No. Unassembled	Part No. Assembled	Width X in. (mm)	Part No. Unassembled	Part No. Assembled	Width X in. (mm)	Part No. Unassembled	Part No. Assembled
0.59 (015)	2300-15	2310-15	2.36 (060)	2300-60	2310-60	3.43 (087)	2300-87	2310-87
0.98 (025)	2300-25	2310-25	2.44 (062)	2300-62	2310-62	3.54 (090)	2300-90	2310-90
1.18 (030)	2300-30	2310-30	2.56 (065)	2300-65	2310-65	3.94 (100)	2300-100	2310-100
1.50 (038)	2300-38	2310-38	2.76 (070)	2300-70	2310-70	4.06 (103)	2300-103	2310-103
1.57 (040)	2300-40	2310-40	2.95 (075)	2300-75	2310-75	4.33 (110)	2300-110	2310-110
1.97 (050)	2300-50	2310-50	3.03 (077)	2300-77	2310-77	4.72 (120)	2300-120	2310-120
2.24 (057)	2300-57	2310-57	3.15 (080)	2300-80	2310-80	4.92 (125)	2300-125	2310-125

Separator with integrated strain relief

Strain relief separator Part No. E6-35-02-Z can be integrated into the mounting bracket and can be placed there at any point of the e-chain®. It combines strain relief and interior separation, it can be installed on the first or last e-chain® link and is easy to assemble without any screws.

For more information ► **Chapter 10, Strain Relief**



PDF: igus.com/e-chain-pdfs
Product information: igus.com/e-chains



Vertical separators

Vertical separators are used if a vertical subdivision of the e-chain® interior is required. By standard, vertical separators are assembled every other e-chain® link.

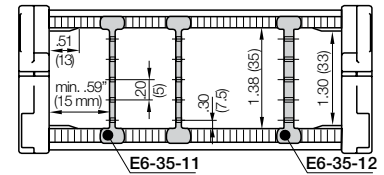

• **Slotted vertical separator E6-35-01**

This separator is used for general subdivision of e-chains®. Can be used in combination with full-width shelf 111-X.

• **Vertical separator E6-35-02**

For use with side plate E6-35-13, full-width shelf 221-X and shelf 2210-X

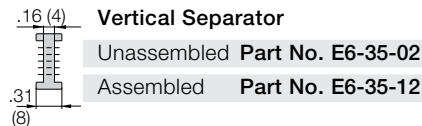
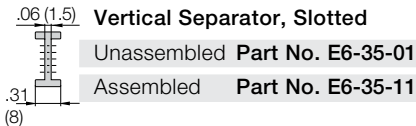

Full-width shelf

For applications involving many thin cables with similar or identical diameters. Full-width shelf 111-X can be used with vertical separator E6-35-11. Full-width shelf 221-X can be used with vertical separator E6-35-12.

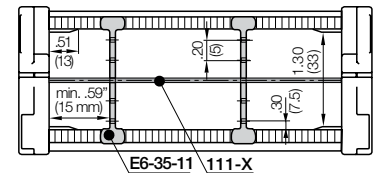

Shelves 110-X/220-XX

Shelves can be inserted at 5 different heights in .20" (5mm) increments

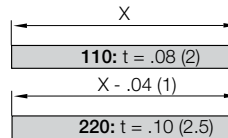

Width X in. (mm)	Part No.		Part No.		Width X in. (mm)	Part No.		Part No.	
	110-X	220-X	111-X	221-X		110-X	220-X	111-X	221-X
1.18 (030)	110-30	220-30	111-30	221-30	3.15 (080)	110-80	220-80	111-80	221-80
1.57 (040)	110-40	220-40	111-40	221-40	3.54 (090)	110-90	220-90	111-90	221-90
1.97 (050)	110-50	220-50	111-50	221-50	3.94 (100)	110-100	220-100	111-100	221-100
2.36 (060)	110-60	220-60	111-60	221-60	4.33 (110)	110-110	220-110	111-110	221-110
2.76 (070)	110-70	220-70	111-70	221-70	4.72 (120)	110-120	220-120	111-120	221-120

Shelves

These components form the basic pattern of a shelf system. Shelves of various widths can be arranged at 5 different heights in .20" (5mm) increments

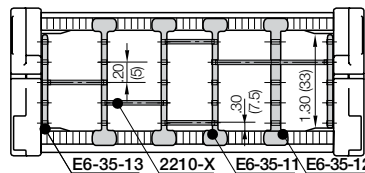

• **Side plate**

This separator is used for general subdivision of e-chains®.



Shelves 2200-XX

Shelf 2210-X can be used with vertical separator E6-35-12 and side plate E6-35-13

Width X in. (mm)	Part No.		Width X in. (mm)	Part No.	
	Unassembled	Assembled		Unassembled	Assembled
.71 (18)	2200-18	2210-18	1.89 (48)	2200-48	2210-48
.91 (23)	2200-23	2210-23	2.28 (58)	2200-58	2210-58
1.10 (28)	2200-28	2210-28	2.68 (68)	2200-68	2210-68
1.30 (33)	2200-33	2210-33	2.87 (73)	2200-73	2210-73
1.50 (38)	2200-38	2210-38	3.46 (88)	2200-88	2210-88
1.69 (43)	2200-43	2210-43	3.90 (99)	2200-99	2210-99

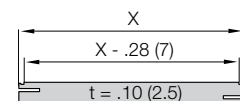

e-chain system® E6

Series E6-35

Mounting Bracket - KMA / Strain Relief



E6-35

KMA - Pivoting

- Bolted connection outside of the chain cross-section
- Recommended for unsupported applications (for gliding applications please contact igus®)
- Confined installation conditions
- Attachment capability on all sides

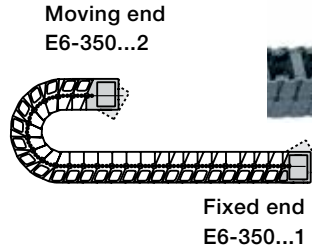

Possible installation configurations -

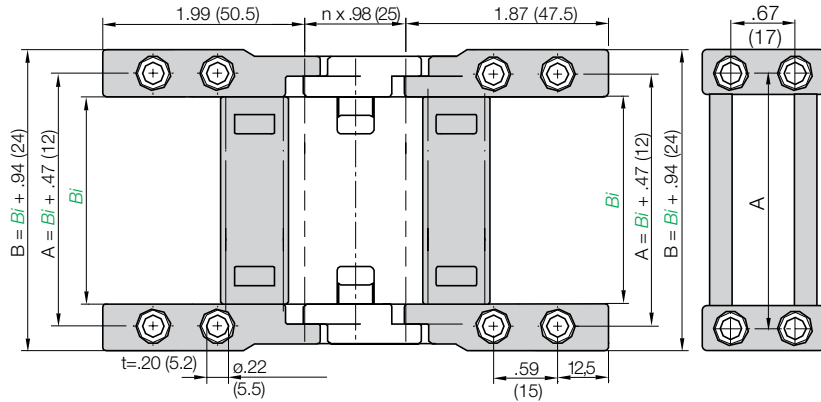

Part Number Structure

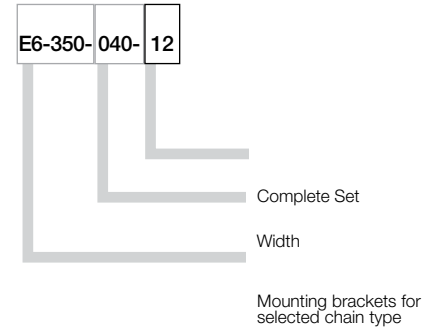

For Series	Part No. Full Set	Dimension B in. (mm)	Dimension A in. (mm)	Bi in. (mm)
E6-35-030	E6-350-030-12	2.13 (54)	1.65 (42)	30
E6-35-040	E6-350-040-12	2.52 (64)	2.05 (52)	40
E6-35-050	E6-350-050-12	2.91 (74)	2.44 (62)	50
E6-35-060	E6-350-060-12	3.31 (84)	2.83 (72)	60
E6-35-070	E6-350-070-12	3.70 (94)	3.23 (82)	70
E6-35-080	E6-350-080-12	4.09 (104)	3.62 (92)	80
E6-35-090	E6-350-090-12	4.49 (114)	4.02 (102)	90
E6-35-100	E6-350-100-12	4.88 (124)	4.41 (112)	100
E6-35-110	E6-350-110-12	5.28 (134)	4.80 (122)	110
E6-35-120	E6-350-120-12	5.67 (144)	5.20 (132)	120
E6-35-140	E6-350-140-12	6.46 (164)	5.98 (152)	140

Full set, for both ends:

E6-350-040-12 Full set, both fixed and moving end

Single-part order:

E6-350-040-1 Mounting bracket fixed end

E6-350-040-2 Mounting bracket moving end

Tiewrap Plates

Tiewrap plates as an individual part

Available as an individual component, can be fixed onto a mounting bracket with the use of a profile rail.

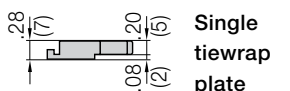
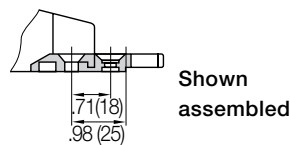

Tiewrap Plates	n Number of Teeth	Dimension C	Dimension B
2020-ZB	3	1.18 (30)	.59 (15)
2030-ZB	4	1.57 (40)	.79 (20)
2040-ZB	5	1.97 (50)	1.18 (30)
2050-ZB	6	2.36 (60)	1.57 (40)
2070-ZB	8	3.15 (80)	2.36 (60)
2090-ZB	9	3.54 (90)	2.76 (70)
2100-ZB	10	3.94 (100)	3.15 (80)
2120-ZB	12	4.72 (120)	3.94 (100)

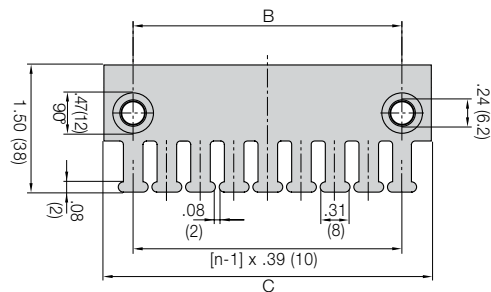

If used with KMA brackets with profile rail please add "KMA" to the end of the part number.

Example: 2020-ZBKMA

Other strain relief elements
 ► Strain Relief, Chapter 10

PDF: igus.com/e-chain-pdfs
 Product information: igus.com/e-chains



Price Index

Series E6-40

Special Options Available



Extremely low noise
Test results upon request



IPA Certificate: Class 1, according to standard DIN EN ISO 14644-1 for the E6 system (Series E6-29-060-150-0-CR, (v = 1.64 ft/s, a = 3.28 ft/s²))

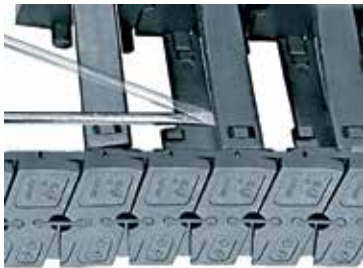

LEVEL 1 absorption confirmed by IPA-Fraunhofer-Institute according to SEMI E78-0998 for the E6 standard material

Assembly Tips

To close, push and click shut

Other Installation Methods

Vertical, hanging ≤ 98.4 ft (30 m)

Vertical, standing ≤ 6.56 ft (2 m)

Side-mounted, un supp. =

possible to a limited extent

Unsupported length of upper run upon request

Usage Guidelines

- If a low-noise version is required
- For very high speeds and/or accelerations
- If large stresses and thrust forces are present
- For small bending radii
- If less vibration is required
- Minimal abrasion, suitable for cleanrooms



- For side mounted applications
➤ Series E4-32 E4-1
- For RBR (Reverse Bending Radius)
➤ Series E4-32 E4-1
- For high additional loads
➤ Series E4-32 E4-1
- For dirty environments
➤ Series E4-32 E4-1

Features & Benefits

- 1 KMA mounting brackets with attachment points on all sides (strain relief with separate tie-wrap plates possible)
- 2 Small pitch for low-noise, smooth operation
- 3 No pin and bore connection, minimal abrasion
- 4 Interior stop dog
- 5 Can be shortened or lengthened due to modular design
- 6 Available with or without integrated profile rail
- 7 Very large gliding surfaces

- Also available:
Separator with integrated strain relief for use in the first or last chain link (Part No. E6-40-02-Z)
➤ Strain Relief, Chapter 10

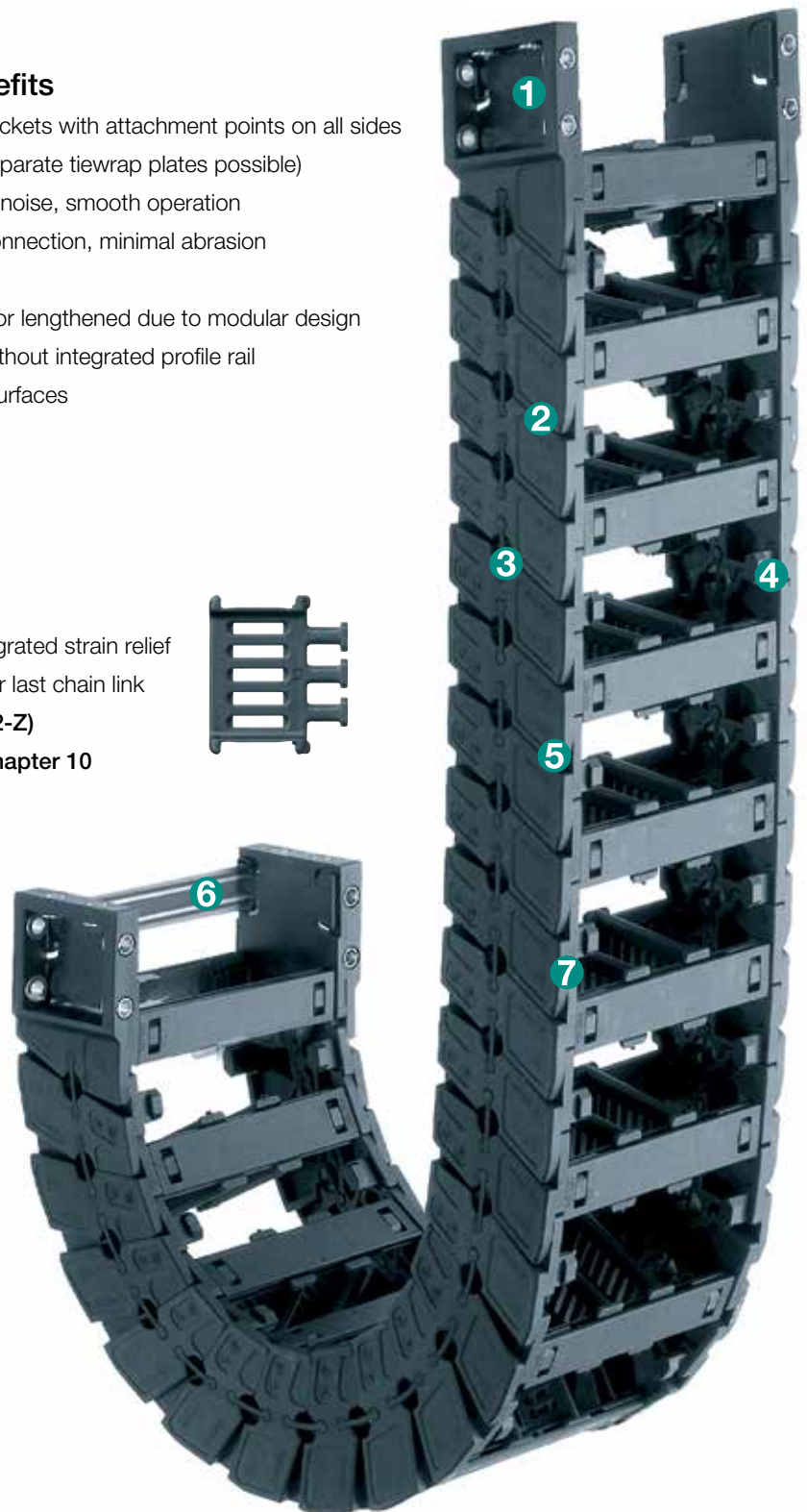
Order Example: Complete e-chain®

Please indicate chain length or number of links. Example:

6.56 ft (2 m) E6-40-100-075-0



e-chain®

With 2 separators 28222 assembled every 2nd link



Interior Separation

1 Set E6-400-100-12



Mounting Bracket

e-chain system® E6

Series E6-40

Installation Dimensions



E6-40

Short travel, unsupported length

- FL_B = unsupported with permitted sag
- FL_G = unsupported with straight upper run

Further information ► Design, Chapter 1

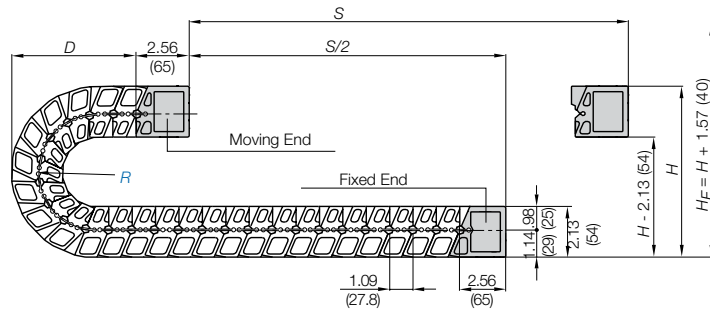
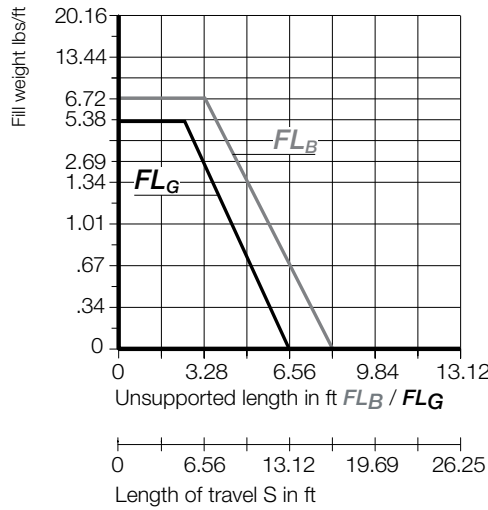
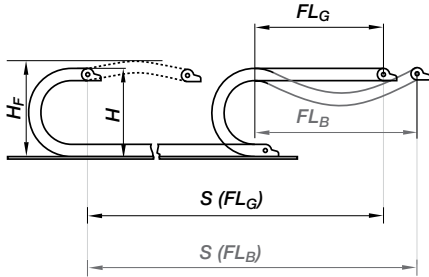

Pitch per link = 1.09" (27.8 mm)
 Links per ft (m) = 10.97 (36)
 For center mount applications:
 Chain length = $\frac{S}{2} + K$

The required clearance height: $H_F = H + 1.57$ in. (40 mm) (with 1.34 lbs/ft (2.0 kg/m) fill weight).
 Please consult igus® if space is particularly restricted.

	2.48 (063)	2.95 (075)	3.94 (100)	4.92 (125)	5.91 (150)	7.87 (200)
R	2.48 (063)	2.95 (075)	3.94 (100)	4.92 (125)	5.91 (150)	7.87 (200)
H	8.82 (224)	9.76 (248)	11.73 (298)	13.71 (348)	15.67 (398)	19.61 (498)
D	5.28 (134)	5.75 (146)	6.73 (171)	7.72 (196)	8.70 (221)	10.67 (271)
K	10.04 (255)	11.61 (295)	14.57 (370)	17.72 (450)	20.87 (530)	26.97 (685)

Short Travels - Unsupported



Unsupported e-chains® feature positive camber over short travels. This must be accounted for when specifying the clearance height. Please refer to **Installation dimensions** for further details.

Legend

- S = Length of travel
- R = Bending radius
- H = Nominal clearance height
- D = Overlength e-chain® radius in final position
- $K = \pi \cdot R + \text{safety buffer}$
- H_F = Required clearance height
- H_{in} = Trough inner height
- H_2 = *Mounting height
- D_2 = Overlength - long travels, gliding
- K_2 = *Add-on

*If the mounting bracket location is set lower

1.57

PDF: igus.com/e-chain-pdfs
 Product information: igus.com/e-chains



Speed / acceleration FL_G	max. 65.6 ft/s (20 m/s) / max. 656 ft/s ² (200 m/s ²)
Speed / acceleration FL_B	max. 9.84 ft/s (3 m/s) / max. 19.69 ft/s ² (6 m/s ²)
Gliding speed / acceleration (maximum)	upon request
Permitted temperature	-40°F (-40°C) up to +158°F (+70° C)
Flammability Class	VDE 0304 IIC UL94 HB

Technical Data



Details of material properties

► Design, Chapter 1

Series E6-40 - e-chain® with crossbars every other link

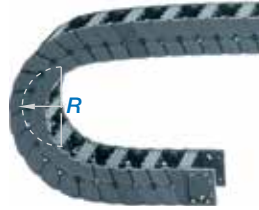
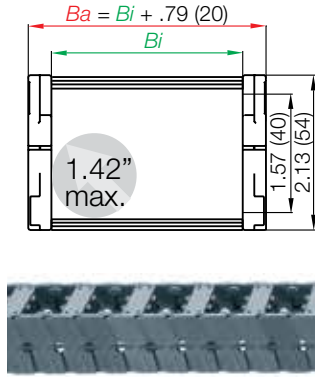

Part Number Structure

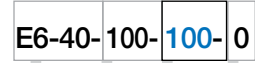

- Color - Black
- Bending radius
- Width
- Series

e-chain® as separate parts, links and side plates

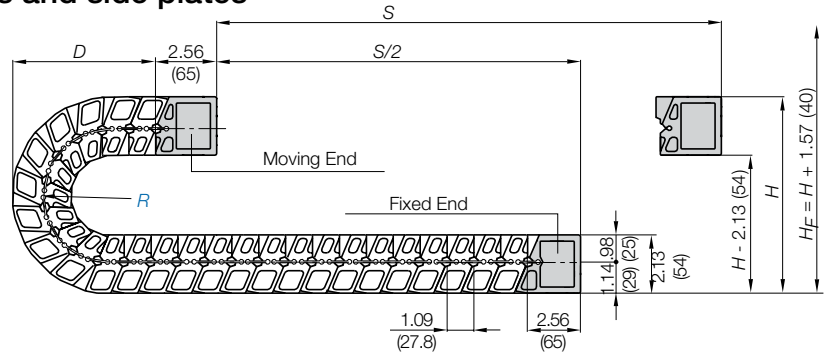
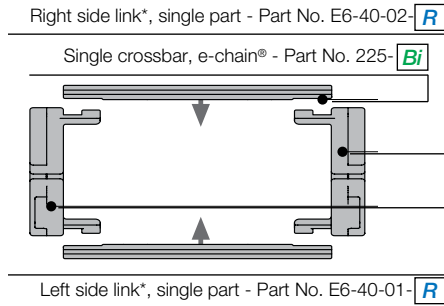

Polymer spring as single part -
Part No. E6-40-177

*View from the fixed point of the e-chain®/E-Tube

Supplement part number with required radius. Example: E6-40-100-100-0
Pitch: 1.09 in. (27.8 mm) per link links/ft (m) = 10.97 (36)

Part Number	Bi in. (mm)	Ba in. (mm)	Weight lbs/ft (kg/m)
E6-40-040- <input type="text"/> -0	1.57 (40)	2.36 (60)	≈ 0.87 (1.29)
E6-40-050- <input type="text"/> -0	1.97 (50)	2.76 (70)	≈ 0.89 (1.33)
E6-40-052- <input type="text"/> -0	2.05 (52)	2.83 (72)	≈ 0.90 (1.34)
E6-40-062- <input type="text"/> -0	2.44 (62)	3.23 (82)	≈ 0.93 (1.38)
E6-40-070- <input type="text"/> -0	2.76 (70)	3.54 (90)	≈ 0.95 (1.41)
E6-40-075- <input type="text"/> -0	2.95 (75)	3.74 (95)	≈ 0.96 (1.43)
E6-40-087- <input type="text"/> -0	3.42 (87)	4.21 (107)	≈ 0.99 (1.48)
E6-40-100- <input type="text"/> -0	3.94 (100)	4.72 (120)	≈ 1.02 (1.53)
E6-40-125- <input type="text"/> -0	4.92 (125)	5.71 (145)	≈ 1.10 (1.63)
E6-40-150- <input type="text"/> -0	5.91 (150)	6.69 (170)	≈ 1.16 (1.73)
E6-40-175- <input type="text"/> -0	6.89 (175)	7.68 (195)	≈ 1.23 (1.83)
E6-40-200- <input type="text"/> -0	7.87 (200)	8.66 (220)	≈ 2.50 (1.93)
E6-40-225- <input type="text"/> -0	8.86 (225)	9.65 (245)	≈ 1.36 (2.02)
E6-40-250- <input type="text"/> -0	9.84 (250)	10.63 (270)	≈ 1.42 (2.12)
E6-40-275- <input type="text"/> -0	10.83 (275)	11.61 (295)	≈ 1.49 (2.22)
E6-40-300- <input type="text"/> -0	11.81 (300)	12.60 (320)	≈ 1.56 (2.32)

Choose from the radii below for all of the above sizes

Radius (mm) Example: E6-40-100-100-0

	063	075	100	125	150	200
R	2.48 (063)	2.95 (075)	3.94 (100)	4.92 (125)	5.91 (150)	7.87 (200)
H	8.82 (224)	9.76 (248)	11.73 (298)	13.71 (348)	15.67 (398)	19.61 (498)
D	5.28 (134)	5.75 (146)	6.73 (171)	7.72 (196)	8.70 (221)	10.67 (271)
K	10.04 (255)	11.61 (295)	14.57 (370)	17.72 (450)	20.87 (530)	26.97 (685)

e-chain system® E6

Series E6-40

Interior Separation - New Generation



E6-40

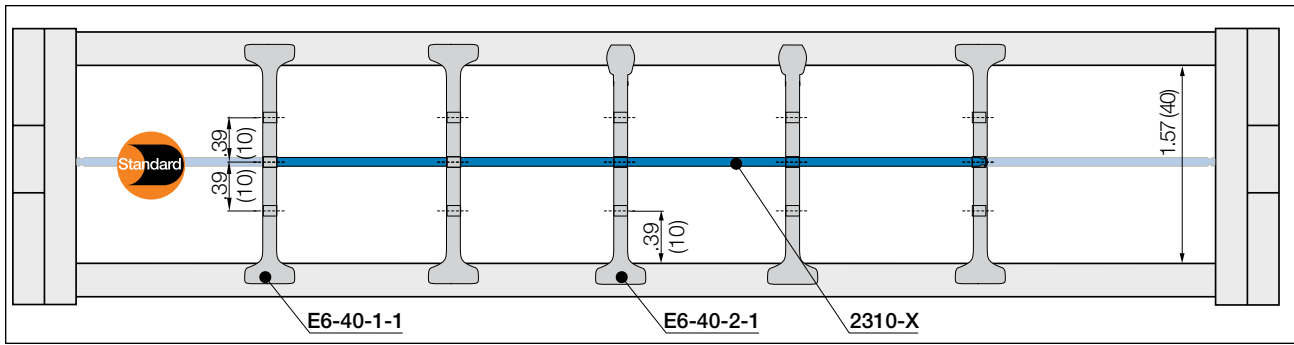

No lateral spacing between the separators and the side links is necessary.
In the standard configuration separators are assembled every 2nd e-chain® link

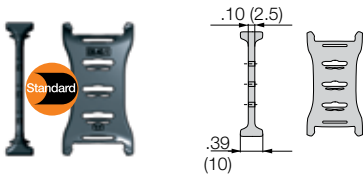

Separator, wide base

Unassembled	Part No. E6-40-1
Assembled	Part No. E6-40-1-1

- **Standard separator E6-40-1 for all applications**

Separator with wide base for maximum locking strength and safe standing in e-chains®.

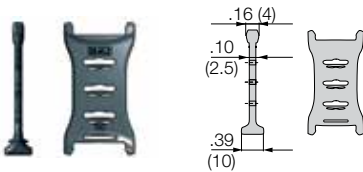

Separator, narrow head

Unassembled	Part No. E6-40-2
Assembled	Part No. E6-40-2-1

- **Separator E6-40-2 For even faster installation**

Firmly holds to one side with a wide base, narrow on opposite side for easy cable assembly (slight grip).

Lockable full-width shelves - for the standard interior separation

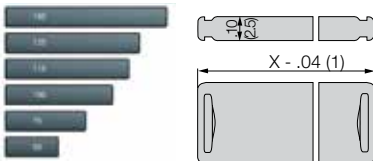

Full width shelf, lockable

Unassembled	Part No. 2300-X
Assembled	Part No. 2310-X

- **Full width shelf, lockable**

Shelf locks safely into separators on both ends, fixed width possible. Separators can be moved freely over the shelf horizontally. Can be arranged at three different heights.

Width X in. (mm)	Part No. Unassembled	Part No. Assembled	Width X in. (mm)	Part No. Unassembled	Part No. Assembled	Width X in. (mm)	Part No. Unassembled	Part No. Assembled
0.59 (015)	2300-15	2310-15	2.36 (060)	2300-60	2310-60	3.43 (087)	2300-87	2310-87
0.98 (025)	2300-25	2310-25	2.44 (062)	2300-62	2310-62	3.54 (090)	2300-90	2310-90
1.18 (030)	2300-30	2310-30	2.56 (065)	2300-65	2310-65	3.94 (100)	2300-100	2310-100
1.50 (038)	2300-38	2310-38	2.76 (070)	2300-70	2310-70	4.06 (103)	2300-103	2310-103
1.57 (040)	2300-40	2310-40	2.95 (075)	2300-75	2310-75	4.33 (110)	2300-110	2310-110
1.97 (050)	2300-50	2310-50	3.03 (077)	2300-77	2310-77	4.72 (120)	2300-120	2310-120
2.24 (057)	2300-57	2310-57	3.15 (080)	2300-80	2310-80	4.92 (125)	2300-125	2310-125

Separator with integrated strain relief

Strain relief separator Part No. E6-40-02-Z can be integrated into the mounting bracket and can be placed there at any point of the e-chain®. It combines strain relief and interior separation, it can be installed on the first or last e-chain® link and is easy to assemble without any screws.

For more information ► Chapter 10, Strain Relief



PDF: igus.com/e-chain-pdfs
Product information: igus.com/e-chains



Vertical separators

Vertical separators are used if a vertical subdivision of the e-chain® interior is required. By standard, vertical separators are assembled every other e-chain® link.

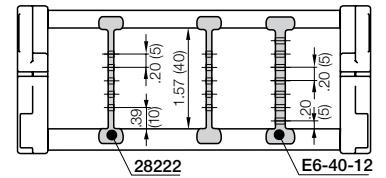

- **Slotted vertical separator**
 This separator is used for general subdivision of e-chains®. Can be used in combination with full-width shelf 221-X.

- **Locking vertical separator**
 For use with shelf 2210-X

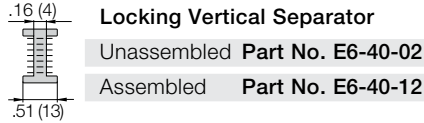
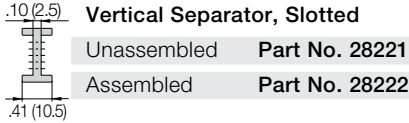

Full-width shelf

For applications involving many thin cables with similar or identical diameters.

Full-width shelf **221-X** can be used with vertical separator **28222**, side plate **E6-40-13** and asymmetrical separator **E6-40-18**

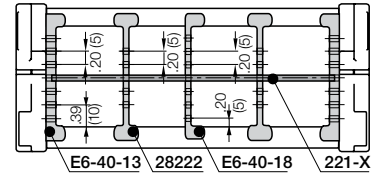

- **Side plate**
 This separator is used for general subdivision of e-chains®.

- **Asymmetrical separator**
 This separator is used for general subdivision of e-chains®.

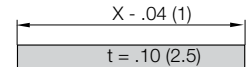
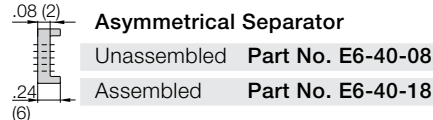
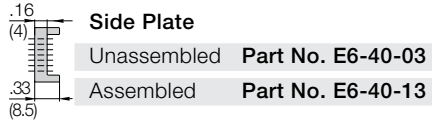

Shelves 220-XX

Shelves can be inserted at 5 different heights in .20" (5mm) increments

Width X in. (mm)	Part No. Unassembled	Part No. Assembled	Width X in. (mm)	Part No. Unassembled	Part No. Assembled
1.57 (040)	220-40	221-40	3.94 (100)	220-100	221-100
1.97 (050)	220-50	221-50	4.92 (125)	220-125	221-125
2.44 (062)	220-62	221-62	5.91 (150)	220-150	221-150
2.76 (070)	220-70	221-70	6.89 (175)	220-175	221-175
2.95 (075)	220-75	221-75	7.87 (200)	220-200	221-200
3.43 (087)	220-87	221-87			

Shelves

These components form the basic pattern of a shelf system. Shelves of various widths can be arranged at 7 different heights in .20" (5mm) increments

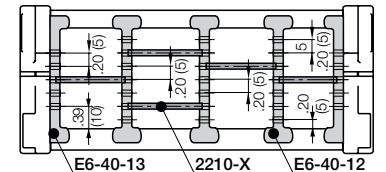

Shelves 2200-XX

Shelf 2210-X can be used with locking vertical separator E6-40-12 and side plate E6-40-13

Width X in. (mm)	Part No. Unassembled	Part No. Assembled	Width X in. (mm)	Part No. Unassembled	Part No. Assembled
.71 (18)	2200-18	2210-18	2.28 (58)	2200-58	2210-58
.91 (23)	2200-23	2210-23	2.28 (63)	2200-65	2210-65
1.10 (28)	2200-28	2210-28	2.68 (68)	2200-68	2210-68
1.30 (33)	2200-33	2210-33	2.87 (73)	2200-73	2210-73
1.50 (38)	2200-38	2210-38	3.46 (88)	2200-88	2210-88
1.69 (43)	2200-43	2210-43	3.90 (99)	2200-99	2210-99
1.89 (48)	2200-48	2210-48			

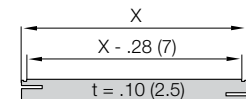

e-chain system® E6

Series E6-40

Mounting Bracket - KMA



E6-40



Option 1: KMA - Pivoting

- Option - profile rail with integrated strain relief chainfix clip or tiwrap plates
- Profile rail can be mounted in the inner or outer radius of the e-chain®
- Bolted connection outside of the chain cross-section
- Recommended for unsupported applications (for gliding applications please contact igus®)
- Confined installation conditions
- Attachment capability on all sides



Adapters for gliding applications available upon request

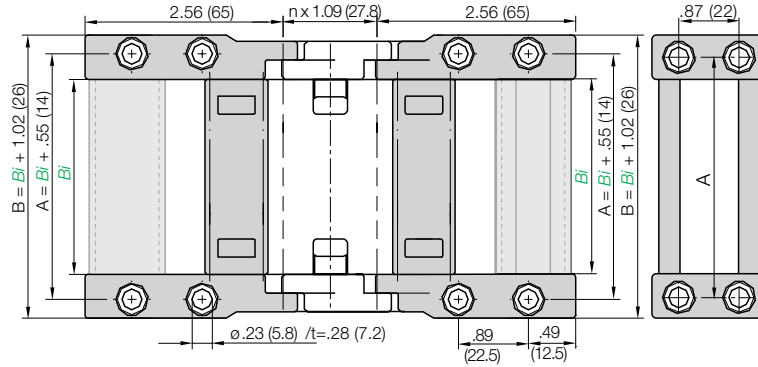
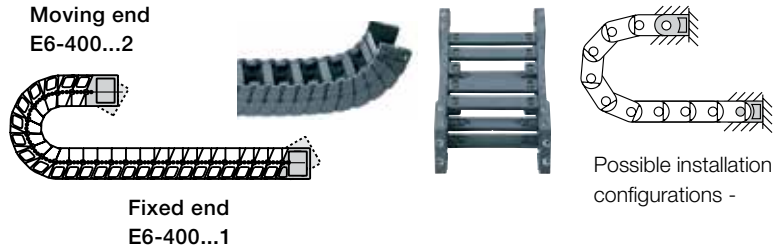

For Series	Part No. Full Set Without Profile Rail	Part No. Full Set With Profile Rail	Dimension A in. (mm)	Dimension B in. (mm)
E6-40-040	E6-400-040-12	E6-400-040-12P	2.13 (54)	2.60 (66)
E6-40-050	E6-400-050-12	E6-400-050-12P	2.52 (64)	2.99 (76)
E6-40-052	E6-400-052-12	E6-400-052-12P	2.66 (66)	3.07 (78)
E6-40-062	E6-400-062-12	E6-400-062-12P	2.99 (76)	3.46 (88)
E6-40-070	E6-400-070-12	E6-400-070-12P	3.31 (84)	3.78 (96)
E6-40-075	E6-400-075-12	E6-400-075-12P	3.50 (89)	3.98 (101)
E6-40-087	E6-400-087-12	E6-400-087-12P	3.98 (101)	4.45 (113)
E6-40-100	E6-400-100-12	E6-400-100-12P	4.49 (114)	4.96 (126)
E6-40-125	E6-400-125-12	E6-400-125-12P	5.47 (139)	5.94 (151)
E6-40-150	E6-400-150-12	E6-400-150-12P	6.46 (164)	6.93 (176)
E6-40-175	E6-400-175-12	E6-400-175-12P	7.44 (189)	7.91 (201)
E6-40-200	E6-400-200-12	E6-400-200-12P	8.43 (214)	8.90 (226)
E6-40-225	E6-400-225-12	E6-400-225-12P	9.41 (239)	9.88 (251)
E6-40-250	E6-400-250-12	E6-400-250-12P	10.39 (264)	10.87 (276)
E6-40-275	E6-400-275-12	E6-400-275-12P	11.38 (289)	11.85 (301)
E6-40-300	E6-400-300-12	E6-400-300-12P	12.36 (314)	12.83 (326)

Part Number Structure

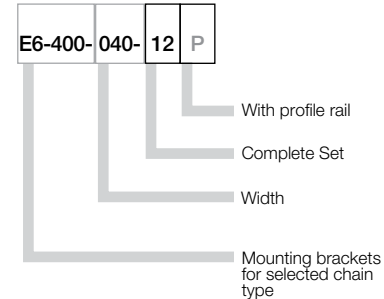

Full set, for both ends:

E6-400- [040-] 12 Full set, both fixed and moving end

Single-part order:

E6-400 - [040-] 1

Mounting bracket fixed end

E6-400 - [040-] 2

Mounting bracket moving end

Tiewrap Plates

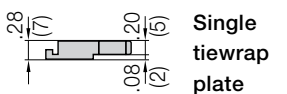
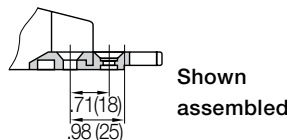

Option 1: Tiewrap plates as an individual part

Available as an individual component, can be fixed onto a mounting bracket with the use of a profile rail.

Tiewrap Plates	n Number of Teeth	Dimension C	Dimension B
2020-ZB	3	1.18 (30)	.59 (15)
2030-ZB	4	1.57 (40)	.79 (20)
2040-ZB	5	1.97 (50)	1.18 (30)
2050-ZB	6	2.36 (60)	1.57 (40)
2070-ZB	8	3.15 (80)	2.36 (60)
2090-ZB	9	3.54 (90)	2.76 (70)
2100-ZB	10	3.94 (100)	3.15 (80)
2120-ZB	12	4.72 (120)	3.94 (100)

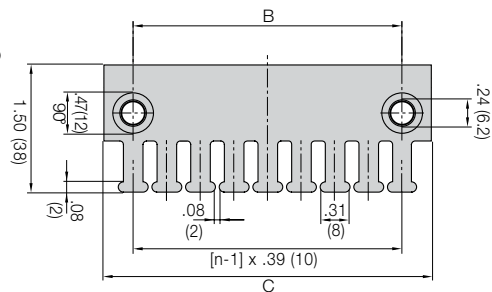

If used with KMA brackets with profile rail please add "KMA" to the end of the part number.

Example: 2020-ZBKMA

- Other strain relief elements
- Strain Relief, Chapter 10

PDF: igus.com/e-chain-pdfs
Product information: igus.com/e-chains



Price Index

Series R6-40

Special Features / Options

Extremely low noise
Test results upon request



IPA Certificate: Class 1, according to standard DIN EN ISO 14644-1 for the E6 system (Series E6-29-060-150-0-CR, (v = 1.64 ft/s, a = 3.28 ft/s²))



LEVEL 1 absorption confirmed by IPA-Fraunhofer-Institute according to SEMI E78-0998 for the E6 standard material

Assembly Tips

Lever and remove lids

Other Installation Methods

Vertical, hanging ≤ 98.4 ft (30 m)

Vertical, standing ≤ 6.56 ft (2 m)

Side-mounted, un_supp. =

possible to a limited extent

Unsupported length of upper run upon request

Usage Guidelines



- If a low-noise version is required
- For very high speeds and/or accelerations
- If large stresses and thrust forces are present
- Protection against hot chips
- For small bending radii
- If less vibration is required
- Minimal abrasion, suitable for cleanrooms



- For side mounted applications
➤ Series R4-32 E4-1

Features & Benefits

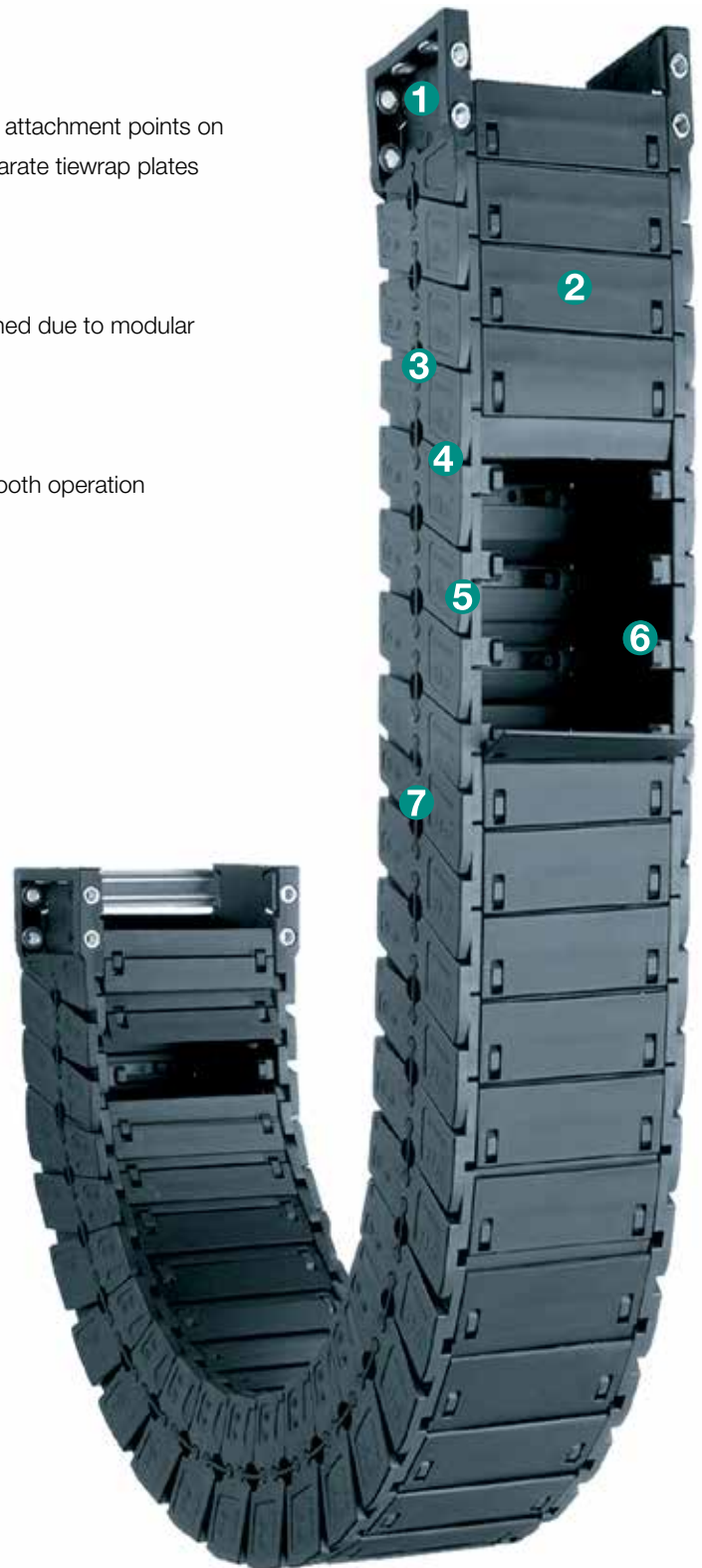
- 1 KMA mounting brackets with attachment points on all sides (strain relief with separate tie-wrap plates possible)
- 2 Fully enclosed E-Tube
- 3 No pin and bore connection
- 4 Can be shortened or lengthened due to modular design
- 5 Very large gliding surfaces
- 6 Interior stop dog
- 7 Small pitch for low-noise, smooth operation

Order Example: Complete e-chain®

Please indicate chain length or number of links. Example:

6.56 ft (2 m) **R6-40-062-075-0****e-chain®**With 2 separators **R6-40-11** assembled every 2nd link**Interior Separation**1 Set **R6-400-062-12****Mounting Bracket**

e-chain system® E6

Series R6-40

Installation Dimensions

Short travel, unsupported length

- FL_B = unsupported with permitted sag
 - FL_G = unsupported with straight upper run
- Further information ► Design, Chapter 1

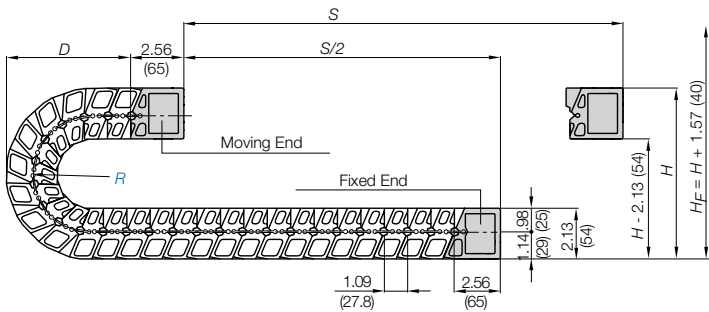
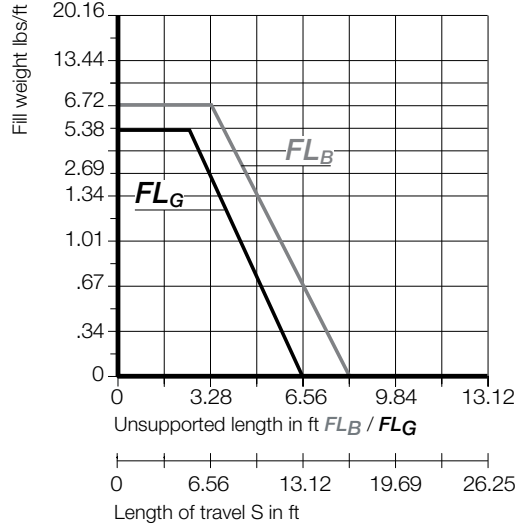
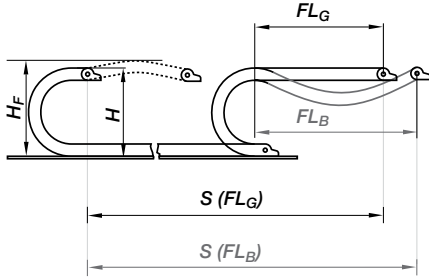

Pitch per link = 1.09" (27.8 mm)
 Links per ft (m) = 10.97 (36)
 For center mount applications:
 Chain length = $\frac{S}{2} + K$

The required clearance height: $H_F = H + 1.57$ in. (40 mm) (with 1.34 lbs/ft (2.0 kg/m) fill weight).
 Please consult igus® if space is particularly restricted.

R	2.48 (063)	2.95 (075)	3.94 (100)	4.92 (125)	5.91 (150)	7.87 (200)
H	8.82 (224)	9.76 (248)	11.73 (298)	13.71 (348)	15.67 (398)	19.61 (498)
D	5.28 (134)	5.75 (146)	6.73 (171)	7.72 (196)	8.70 (221)	10.67 (271)
K	10.04 (255)	11.61 (295)	13.50 (343)	16.65 (423)	20.87 (530)	26.97 (685)



R6-40

Short Travels - Unsupported

1.57



Unsupported e-chains® feature positive camber over short travels. This must be accounted for when specifying the clearance height. Please refer to **Installation dimensions** for further details.

Legend

- S = Length of travel
- R = Bending radius
- H = Nominal clearance height
- D = Overlength e-chain® radius in final position
- $K = \pi \cdot R + \text{safety buffer}$
- H_F = Required clearance height
- H_{in} = Trough inner height
- H_2 = *Mounting height
- D_2 = Overlength - long travels, gliding
- K^2 = *Add-on

*If the mounting bracket location is set lower

PDF: igus.com/e-chain-pdfs
 Product information: igus.com/e-chains



Speed / acceleration FL_G	max. 65.6 ft/s (20 m/s) / max. 656 ft/s ² (200 m/s ²)
Speed / acceleration FL_B	max. 9.84 ft/s (3 m/s) / max. 19.69 ft/s ² (6 m/s ²)
Gliding speed / acceleration (maximum)	upon request
Permitted temperature	-40°F (-40°C) up to +158°F (+70° C)
Flammability Class	VDE 0304 IIC UL94 HB

Technical Data



Details of material properties

► Design, Chapter 1

Series R6-40 - E-Tube, removable lids along the inner and outer radius

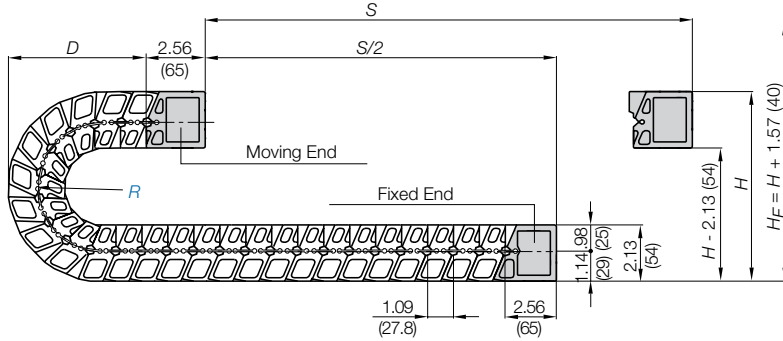
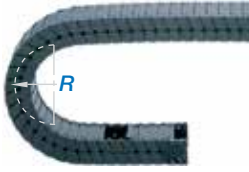
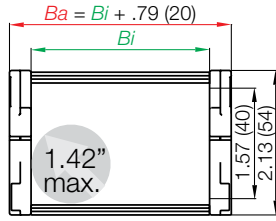

Part Number Structure

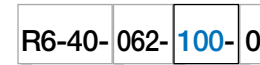

- Color - Black
- Bending radius
- Width
- Series

Supplement part number with required radius. Example: R6-40-062-**100**-0
Pitch: 1.09 in. (27.8 mm) per link links/ft (m) = 10.97 (36)

Part Number	Bi in. (mm)	Ba in. (mm)	Weight lbs/ft (kg/m)
R6-40-062- <input type="text"/> -0	2.44 (62)	3.23 (82)	≈ 1.07 (1.59)
R6-40-075- <input type="text"/> -0	2.95 (75)	3.74 (95)	≈ 1.11 (1.65)

Choose from the radii below for all of the above sizes
Radius (mm) Example: R6-40-062-**100**-0

	063	075	100	125	150	200
R	2.48 (63)	2.95 (75)	3.94 (100)	4.92 (125)	5.91 (150)	7.87 (200)
H	8.82 (224)	9.76 (248)	11.73 (298)	13.71 (348)	15.67 (398)	19.61 (498)
D	5.28 (134)	5.75 (146)	6.73 (171)	7.72 (196)	8.70 (221)	10.67 (271)
K	10.04 (255)	11.61 (295)	13.50 (343)	16.65 (423)	20.87 (530)	26.97 (685)

Vertical separators

Vertical separators are used if a vertical subdivision of the e-chain® interior is required. By standard, vertical separators are assembled every other E-Tube link.

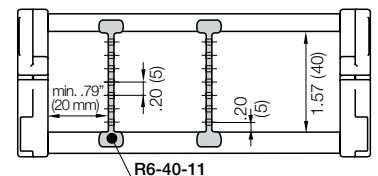

Vertical separator R6-40-01

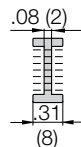

Vertical Separator

Unassembled Part No. R6-40-01

Assembled Part No. R6-40-11

- Vertical separator R6-40-01
This separator is used for general subdivision of E-Tubes.
- Separator snaps onto either the bottom of the carrier or the lid. Stays attached to that side. Opposite side can be removed.

e-chain system® E6

Series R6-40

Mounting Bracket - KMA / Strain Relief



R6-40



KMA - Pivoting

- Option - profile rail with integrated strain relief chainfix clip or tiewrap plates
- Profile rail can be mounted in the inner or outer radius of the e-chain®
- Bolted connection outside of the chain cross-section
- Recommended for unsupported applications (for gliding applications please contact igus®)
- Confined installation conditions
- Attachment capability on all sides

Moving end
R6-400...2

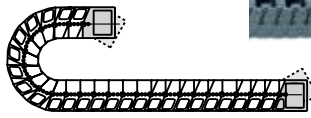

Fixed end
R6-400...1

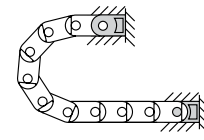

Possible installation configurations -



Adapters for gliding applications available upon request

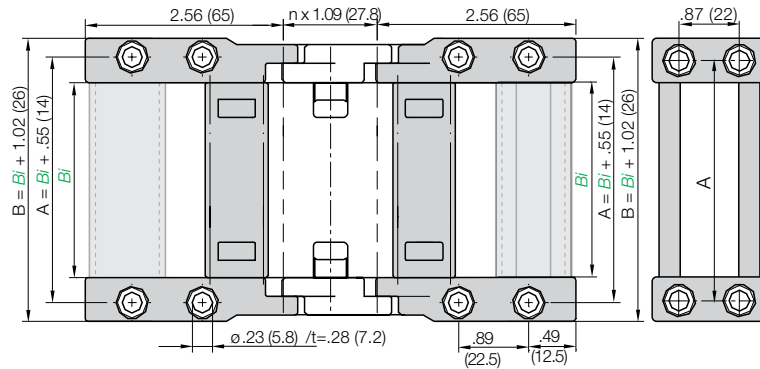

For Series	Part No. Full Set Without Profile Rail	Part No. Full Set With Profile Rail	Dimension A		Dimension B	
			in.	(mm)	in.	(mm)
R6-40-062	R6-400-062-12	R6-400-062-12P	2.99	(76)	3.46	(88)
R6-40-075	R6-400-075-12	R6-400-075-12P	3.50	(89)	3.98	(101)

Full set, for both ends:

R6-400-062-12 Full set, both fixed and moving end

Single-part order:

R6-400-062-1 Mounting bracket fixed end

R6-400-062-2 Mounting bracket moving end

Tiewrap Plates



Tiewrap plates as an individual part

Available as an individual component, can be fixed onto a mounting bracket with the use of a profile rail.

Tiewrap Plates	n Number of Teeth	Dimension C	Dimension B
2020-ZB	3	1.18 (30)	.59 (15)
2030-ZB	4	1.57 (40)	.79 (20)
2040-ZB	5	1.97 (50)	1.18 (30)
2050-ZB	6	2.36 (60)	1.57 (40)
2070-ZB	8	3.15 (80)	2.36 (60)
2090-ZB	9	3.54 (90)	2.76 (70)
2100-ZB	10	3.94 (100)	3.15 (80)
2120-ZB	12	4.72 (120)	3.94 (100)

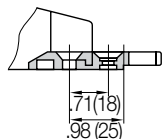

Shown assembled

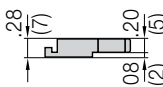

Single tiewrap plate

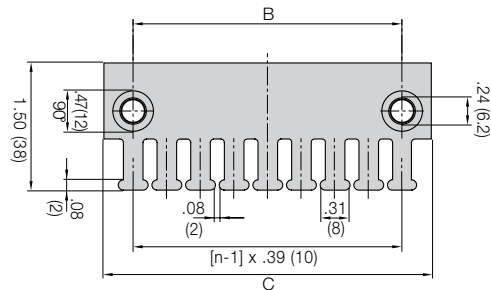

If used with KMA brackets with profile rail please add "KMA" to the end of the part number.

Example: 2020-ZBKMA

Other strain relief elements
► Strain Relief, Chapter 10

PDF: igus.com/e-chain-pdfs
Product information: igus.com/e-chains



Price Index

Series E6-52

Special Features / Options



Extremely low noise
Test results upon request



IPA Certificate: Class 1, according to standard DIN EN ISO 14644-1 for the E6 system (Series E6-29-060-150-0-CR, (v = 1.64 ft/s, a = 3.28 ft/s²))



LEVEL 1 absorption confirmed by IPA-Fraunhofer-Institute according to SEMI E78-0998 for the E6 standard material

Assembly Tips



To close, push and click shut

Other Installation Methods

Vertical, hanging ≤ 164 ft (50 m)

Vertical, standing ≤ 6.56 ft (2 m)

Side-mounted, un_supp. =

possible to a limited extent

Unsupported length of upper run upon request

Usage Guidelines



- If a low-noise version is required
- For very high speeds and/or accelerations
- If large stresses and thrust forces are present
- For small bending radii
- If less vibration is required
- Minimal abrasion, suitable for cleanrooms



- For side mounted applications
 - **Series E4-56 E4-1**
- For RBR (Reverse Bending Radius)
 - **Series E4-56 E4-1**
- For high additional loads
 - **Series E4-56 E4-1**
- For dirty environments
 - **Series E4-56 E4-1**

Features & Benefits

- 1 KMA mounting brackets with attachment points on all sides (strain relief with separate tie-wrap plates possible)
- 2 No pin and bore connection
- 3 Interior stop dog
- 4 Very large gliding surfaces
- 5 Small pitch for low-noise, smooth operation
- 6 Can be shortened or lengthened due to modular design
- 7 Available with or without integrated profile rail

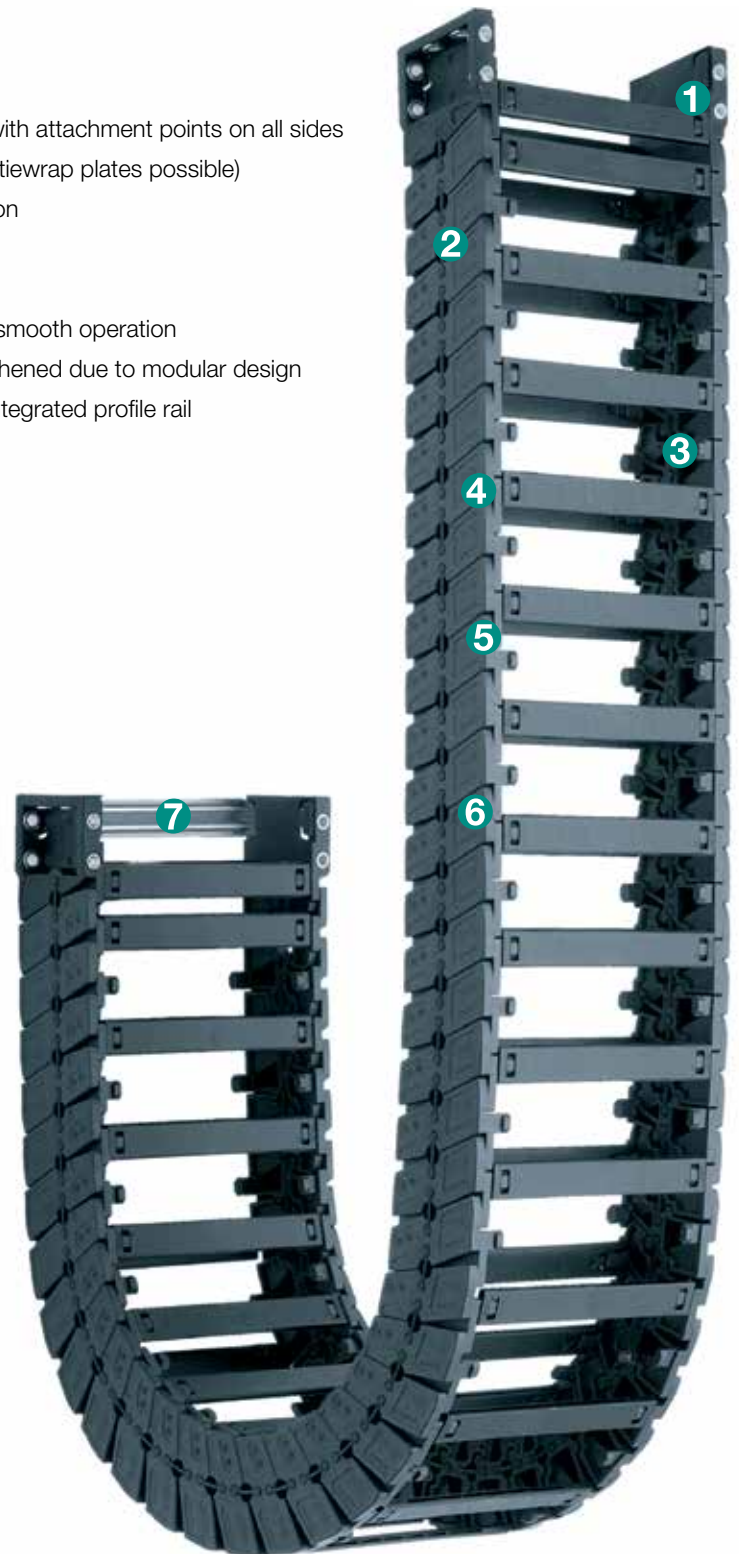

Order Example: Complete e-chain®

Please indicate chain length or number of links. Example:

6.56 ft (2 m) **E6-52-100-175-0**



e-chain®

With 2 separators **38222** assembled every 2nd link



Interior Separation

1 Set **E6-520-100-12**



Mounting Bracket

e-chain system® E6

Series E6-52

Installation Dimensions

Short travel, unsupported length

- FL_B = unsupported with permitted sag
 - FL_G = unsupported with straight upper run
- Further information ► Design, Chapter 1

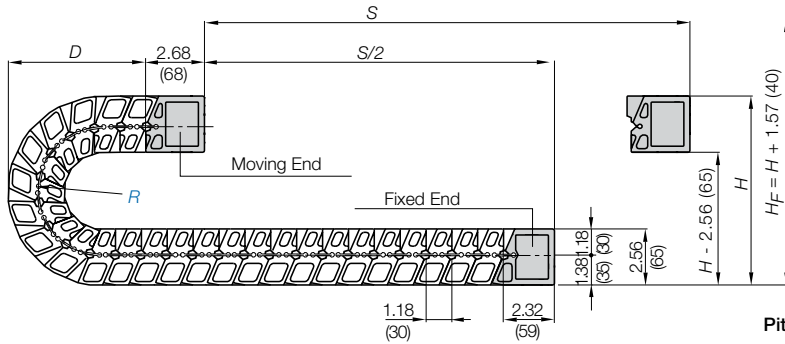
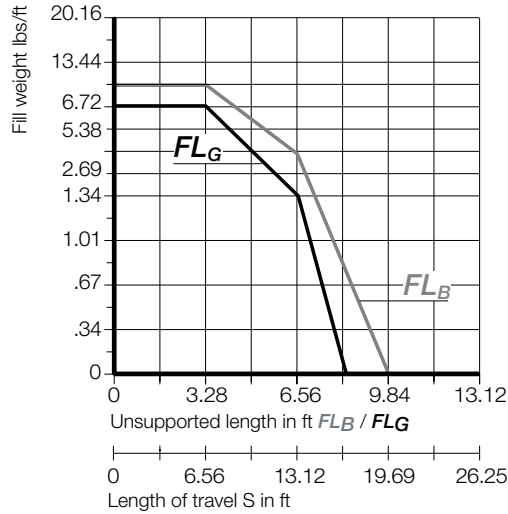
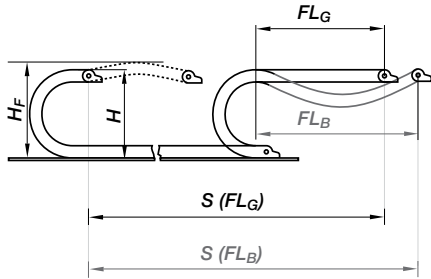

The required clearance height: $H_F = H + 1.57$ in. (40 mm) (with 1.34 lbs/ft (2.0 kg/m) fill weight. Please consult igus® if space is particularly restricted.

Pitch per link = 1.18" (30 mm)
 Links per ft (m) = 10.17 (34)
 For center mount applications:
 Chain length = $S/2 + K$

R	2.95 (075)	3.94 (100)	5.91 (150)	7.87 (200)	9.84 (250)
H	10.63 (270)	12.60 (320)	16.54 (420)	20.47 (520)	24.41 (620)
D	6.10 (155)	7.09 (180)	9.06 (230)	11.02 (280)	12.99 (330)
K	11.81 (300)	14.76 (375)	21.06 (535)	27.17 (690)	33.46 (850)



E6-52

Short Travels - Unsupported



Unsupported e-chains® feature positive camber over short travels. This must be accounted for when specifying the clearance height. Please refer to **Installation dimensions** for further details.

Legend

- S = Length of travel
- R = Bending radius
- H = Nominal clearance height
- D = Overlength e-chain® radius in final position
- $K = \pi \cdot R + \text{safety buffer}$
- H_F = Required clearance height
- H_{in} = Trough inner height
- H_2 = *Mounting height
- D_2 = Overlength - long travels, gliding
- K_2 = *Add-on

*If the mounting bracket location is set lower

2.05

PDF: igus.com/e-chain-pdfs
 Product information: igus.com/e-chains



Speed / acceleration FL_G	max. 65.6 ft/s (20 m/s) / max. 656 ft/s ² (200 m/s ²)
Speed / acceleration FL_B	max. 9.84 ft/s (3 m/s) / max. 19.69 ft/s ² (6 m/s ²)
Gliding speed / acceleration (maximum)	upon request
Permitted temperature	-40°F (-40°C) up to +158°F (+70° C)
Flammability Class	VDE 0304 IIC UL94 HB

Technical Data



Details of material properties

► Design, Chapter 1

7.98

Series E6-52 - e-chain® with crossbars every other link

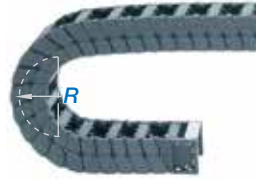
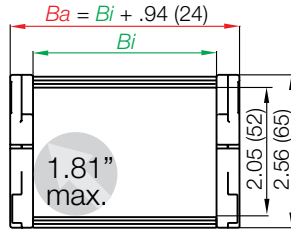

Part Number Structure

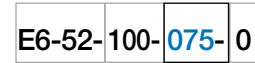

- Color - Black
- Bending radius
- Width
- Series



e-chain® as separate parts, side links and crossbars

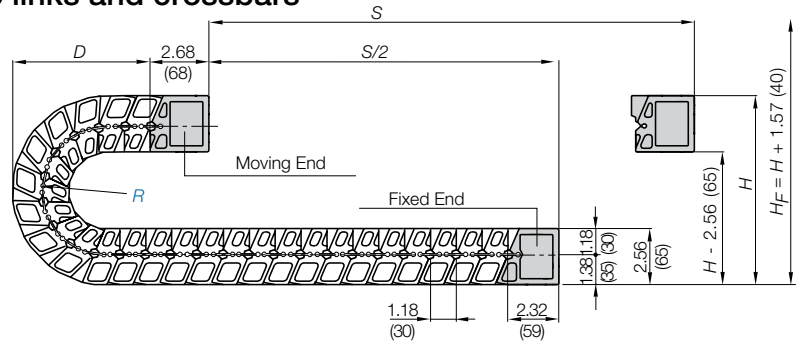
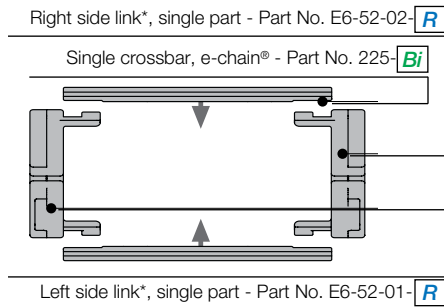

Polymer spring as single part -
Part No. E6-52-195

*View from the fixed point of the e-chain®/E-Tube

Supplement part number with required radius. Example: E6-52-100-075-0
Pitch: 1.18 in. (30 mm) per link links/ft (m) = 10.36 (34)

Part Number	Bi in. (mm)	Ba in. (mm)	Weight lbs/ft (kg/m)
E6-52-040- -0	1.57 (40)	2.51 (64)	≈1.18 (1.76)
E6-52-050- -0	1.97 (50)	2.91 (74)	≈1.21 (1.80)
E6-52-052- -0	2.05 (52)	2.60 (66)	≈1.22 (1.81)
E6-52-062- -0	2.44 (62)	3.39 (86)	≈1.24 (1.84)
E6-52-070- -0	2.76 (70)	3.70 (94)	≈1.26 (1.87)
E6-52-075- -0	2.95 (75)	3.90 (99)	≈1.27 (1.89)
E6-52-087- -0	3.42 (87)	4.37 (111)	≈1.30 (1.94)
E6-52-100- -0	3.94 (100)	4.88 (124)	≈1.33 (1.98)
E6-52-125- -0	4.92 (125)	5.87 (149)	≈1.39 (2.07)
E6-52-150- -0	5.91 (150)	6.85 (174)	≈1.46 (2.17)
E6-52-175- -0	6.89 (175)	7.83 (199)	≈1.52 (2.26)
E6-52-200- -0	7.87 (200)	8.82 (224)	≈1.59 (2.36)
E6-52-225- -0	8.86 (225)	9.80 (249)	≈1.65 (2.45)
E6-52-250- -0	9.84 (250)	10.79 (274)	≈1.71 (2.54)
E6-52-275- -0	10.83 (275)	11.77 (299)	≈1.77 (2.64)
E6-52-300- -0	11.81 (300)	12.76 (324)	≈1.83 (2.73)

Choose from the radii below for all of the above sizes

Radius (mm) Example: E6-52-100-075-0

	075	100	150	200	250
R	2.95 (075)	3.94 (100)	5.91 (150)	7.87 (200)	9.84 (250)
H	10.63 (270)	12.60 (320)	16.54 (420)	20.47 (520)	24.41 (620)
D	6.10 (155)	7.09 (180)	9.06 (230)	11.02 (280)	12.99 (330)
K	11.81 (300)	14.76 (375)	21.06 (535)	27.17 (690)	33.46 (850)

e-chain system® E6
 Series E6-52
 Interior Separation - New Generation



E6-52

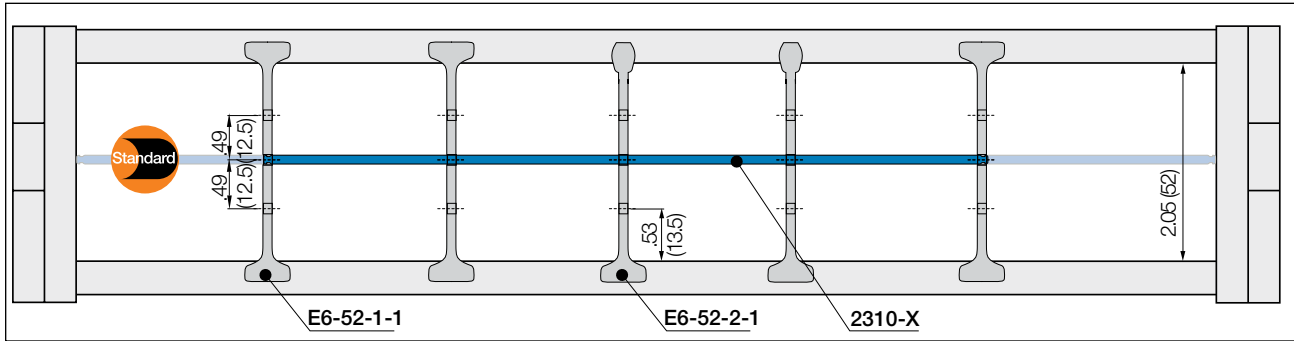

No lateral spacing between the separators and the side links is necessary.
 In the standard configuration separators are assembled every 2nd e-chain® link

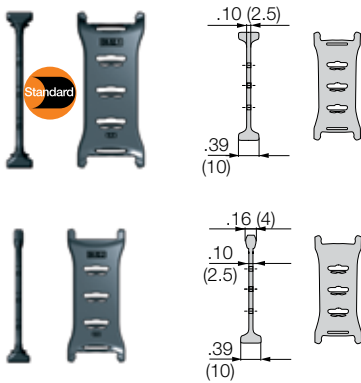

Separator, wide base
 Unassembled Part No. E6-52-1
 Assembled Part No. E6-52-1-1

- **Standard separator E6-52-1 for all applications**
 Separator with wide base for maximum locking strength and safe standing in e-chains®.

Separator, narrow head
 Unassembled Part No. E6-52-2
 Assembled Part No. E6-52-2-1

- **Separator E6-52-2 For even faster installation**
 Firmly holds to one side with a wide base, narrow on opposite side for easy cable assembly (slight grip).

Lockable full-width shelves - for the standard interior separation

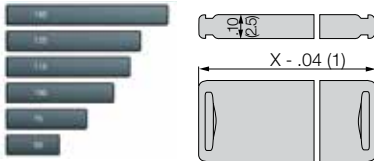

Full width shelf, lockable
 Unassembled Part No. 2300-X
 Assembled Part No. 2310-X

- **Full width shelf, lockable**
 Shelf locks safely into separators on both ends, fixed width possible. Separators can be moved freely over the shelf horizontally. Can be arranged at three different heights.

Width X in. (mm)	Part No. Unassembled	Part No. Assembled	Width X in. (mm)	Part No. Unassembled	Part No. Assembled	Width X in. (mm)	Part No. Unassembled	Part No. Assembled
0.59 (015)	2300-15	2310-15	2.36 (060)	2300-60	2310-60	3.43 (087)	2300-87	2310-87
0.98 (025)	2300-25	2310-25	2.44 (062)	2300-62	2310-62	3.54 (090)	2300-90	2310-90
1.18 (030)	2300-30	2310-30	2.56 (065)	2300-65	2310-65	3.94 (100)	2300-100	2310-100
1.50 (038)	2300-38	2310-38	2.76 (070)	2300-70	2310-70	4.06 (103)	2300-103	2310-103
1.57 (040)	2300-40	2310-40	2.95 (075)	2300-75	2310-75	4.33 (110)	2300-110	2310-110
1.97 (050)	2300-50	2310-50	3.03 (077)	2300-77	2310-77	4.72 (120)	2300-120	2310-120
2.24 (057)	2300-57	2310-57	3.15 (080)	2300-80	2310-80	4.92 (125)	2300-125	2310-125

PDF: igus.com/e-chain-pdfs
 Product information: igus.com/e-chains



Vertical separators and spacers

Vertical separators are used if a vertical subdivision of the e-chain® interior is required. By standard, vertical separators are assembled every other e-chain® link.

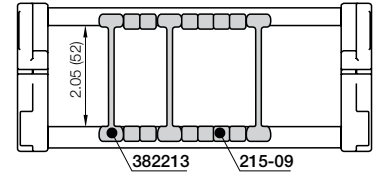

● **Vertical separator**

This separator is used for general subdivision of e-chains®.

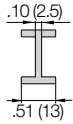

Vertical Separator

Unassembled	Part No. 382212
Assembled	Part No. 382213

● **Spacer**

Used when a broad distance needs to be maintained between the separators. Generally used in side-mounted applications



Spacer

Unassembled	Part No. 205-09
Assembled	Part No. 215-09

Full-width shelf

For applications involving many thin cables with similar or identical diameters. Slotted separator **38226** and **38229** can be used in combination with full-width shelf **321-X**. Locking vertical separator **382215** can also be used with full-width shelf **221-X**.

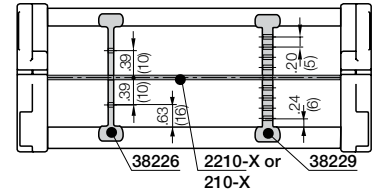

Width X in. (mm)	Part No. Unassembled		Part No. Assembled	
	220-X	320-X	221-X	321-X
1.57 (040)	220-40	320-40	221-40	321-40
1.97 (050)	220-50	320-50	221-50	321-50
2.44 (062)	220-62	320-62	221-62	321-62
2.76 (070)	220-70	320-70	221-70	321-70
2.95 (075)	220-75	320-75	221-75	321-75
3.43 (087)	220-87	320-87	221-87	321-87
3.94 (100)	220-100	320-100	221-100	321-100
4.92 (125)	220-125	320-125	221-125	321-125
5.91 (150)	220-150	320-150	221-150	321-150
6.89 (175)	220-175	320-175	221-175	321-175
7.87 (200)	220-200	320-200	221-200	321-200

Shelves 220-X/320-XX
 Shelves can be inserted at 9 different heights in .20" (5mm) increments

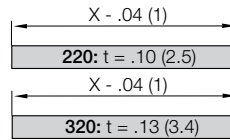

● **Vertical separator, slotted**

This separator is used for general subdivision of e-chains®. Can be used in combination with full-width shelf 321-X.

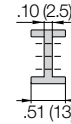

Vertical Separator, slotted

Unassembled	Part No. 38225
Assembled	Part No. 38226

● **Locking vertical separator**

This separator is used for general subdivision of e-chains®.

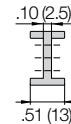

Locking Vertical Separator

Unassembled	Part No. 38228
Assembled	Part No. 38229

Shelves

These components form the basic pattern of a shelf system. Shelves of various widths can be arranged at 9 different heights in .20" (5mm) increments

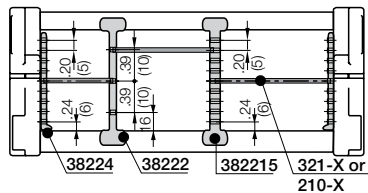

Shelves 2200-XX

Shelf **2210-X** can be used with **vertical separator 38222**, **locking separator 382215** and **side plate 38224**.

Locking vertical separator **382215** can also be used with full-width shelf **221-X**.

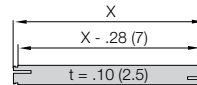

Width X in. (mm)	Part No.		Width X in. (mm)	Part No.	
	Unassembled	Assembled		Unassembled	Assembled
.71 (18)	2200-18	2210-18	2.28 (58)	2200-58	2210-58
.91 (23)	2200-23	2210-23	2.28 (63)	2200-65	2210-65
1.10 (28)	2200-28	2210-28	2.68 (68)	2200-68	2210-68
1.30 (33)	2200-33	2210-33	2.87 (73)	2200-73	2210-73
1.50 (38)	2200-38	2210-38	3.46 (88)	2200-88	2210-88
1.69 (43)	2200-43	2210-43	3.90 (99)	2200-99	2210-99
1.89 (48)	2200-48	2210-48			

● **Locking vertical separator**

This separator is used when higher retention force is needed.

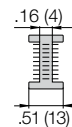

Locking Vertical Separator

Unassembled	Part No. 382214
Assembled	Part No. 382215

● **Side plate**

This separator is used for general subdivision of e-chains®.

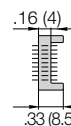

Side Plate

Unassembled	Part No. 38223
Assembled	Part No. 38224

● **Vertical separator, slotted**

Can be used in combination with full-width shelf 321-X.

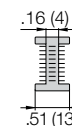

Vertical Separator, Slotted

Unassembled	Part No. 38221
Assembled	Part No. 38222



Option 1: KMA - Pivoting

- Option - profile rail with integrated strain relief chainfix clip or tiwrap plates
- Profile rail can be mounted in the inner or outer radius of the e-chain®
- Bolted connection outside of the chain cross-section
- Recommended for unsupported applications (for gliding applications please contact igus®)
- Confined installation conditions
- Attachment capability on all sides



Adapters for gliding applications available upon request

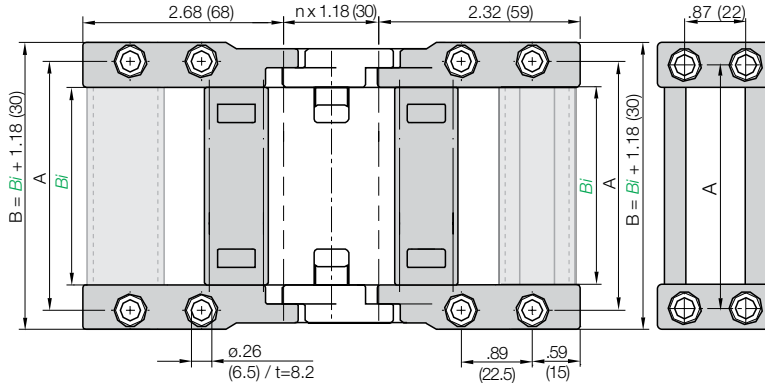
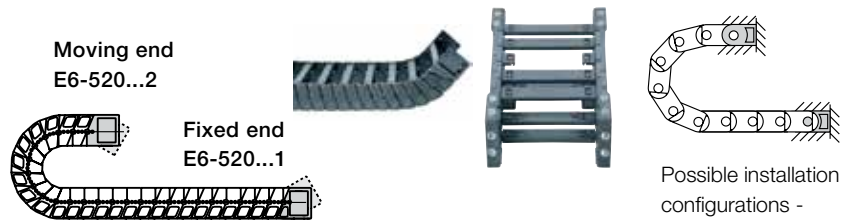

For Series	Part No. Full Set Without Profile Rail	Part No. Full Set With Profile Rail	Dimension A in. (mm)	Dimension B in. (mm)
E6-52-040	E6-520-040-12	E6-520-040-12P	2.20 (56)	2.76 (70)
E6-52-050	E6-520-050-12	E6-520-050-12P	2.60 (66)	3.15 (80)
E6-52-052	E6-520-052-12	E6-520-052-12P	2.68 (68)	3.23 (82)
E6-52-062	E6-520-062-12	E6-520-062-12P	3.07 (78)	3.62 (92)
E6-52-070	E6-520-070-12	E6-520-070-12P	3.39 (86)	3.94 (100)
E6-52-075	E6-520-075-12	E6-520-075-12P	3.58 (91)	4.13 (105)
E6-52-087	E6-520-087-12	E6-520-087-12P	4.06 (103)	4.61 (117)
E6-52-100	E6-520-100-12	E6-520-100-12P	4.57 (116)	5.12 (130)
E6-52-125	E6-520-125-12	E6-520-125-12P	5.55 (141)	6.10 (155)
E6-52-150	E6-520-150-12	E6-520-150-12P	6.54 (166)	7.09 (180)
E6-52-175	E6-520-175-12	E6-520-175-12P	7.52 (191)	8.07 (205)
E6-52-200	E6-520-200-12	E6-520-200-12P	8.50 (216)	9.06 (230)
E6-52-225	E6-520-225-12	E6-520-225-12P	9.49 (241)	10.04 (255)
E6-52-250	E6-520-250-12	E6-520-250-12P	10.47 (266)	11.02 (280)
E6-52-275	E6-520-275-12	E6-520-275-12P	11.46 (291)	11.81 (300)
E6-52-300	E6-520-300-12	E6-520-300-12P	12.44 (316)	12.99 (330)

Part Number Structure

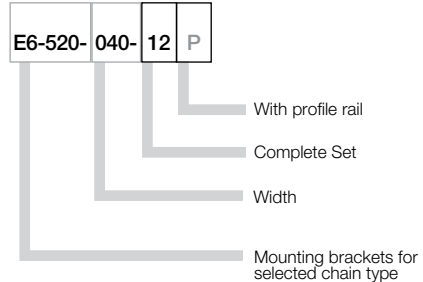

Full set, for both ends:

E6-520-040-12 Full set, both fixed and moving end

Single-part order:
E6-520-040-1

Mounting bracket fixed end

E6-520-040-2

Mounting bracket moving end

Tiewrap Plates

Option 1: Tiewrap plates as an individual part

Available as an individual component, can be fixed onto a mounting bracket with the use of a profile rail.

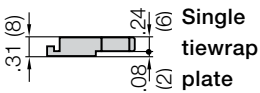
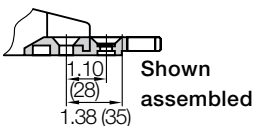

Tiewrap Plate	n Number of Teeth	C Overall Width in. (mm)	B Bore Width in. (mm)	Center Bore
3050-ZB	5	1.97 (50)	1.18 (30)	no
3075-ZB	7	2.95 (75)	2.16 (55)	no
3100-ZB	10	3.94 (100)	3.15 (80)	no
3115-ZB	11	4.53 (115)	3.74 (95)	no
3125-ZB	12	4.92 (125)	4.13 (105)	no
3150-ZB	15	5.91 (150)	5.12 (130)	no
3175-ZB	17	6.89 (175)	6.10 (155)	no
3200-ZB	20	7.87 (200)	7.09 (180)	yes
3225-ZB	22	8.86 (225)	8.07 (205)	yes
3250-ZB	25	9.84 (250)	9.06 (230)	yes

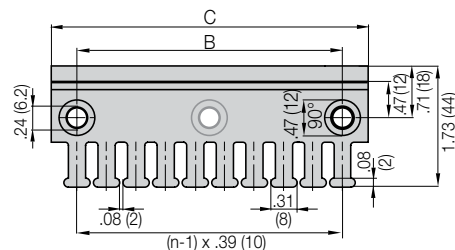

If used with KMA brackets with profile rail please add "KMA" to the end of the part number.

Example: 3050-ZBKMA

Other strain relief elements

► Strain Relief, Chapter 10



Price Index



Series R6-52

Special Features / Options



Extremely low noise
Test results upon request



IPA Certificate: Class 1, according to standard DIN EN ISO 14644-1 for the E6 system (Series E6-29-060-150-0-CR, (v = 1.64 ft/s, a = 3.28 ft/s²))



LEVEL 1 absorption confirmed by IPA-Fraunhofer-Institute according to SEMI E78-0998 for the E6 standard material

Assembly Tips



Lever and remove lids

Other Installation Methods

Vertical, hanging ≤ 164 ft (50 m)

Vertical, standing ≤ 6.56 ft (2 m)

Side-mounted, unsupp. =

possible to a limited extent

Unsupported length of upper run upon request

Usage Guidelines



- If a low-noise version is required
- For very high speeds and/or accelerations
- If large stresses and thrust forces are present
- Protection against dirt and chips
- For small bending radii
- If less vibration is required
- Minimal abrasion, suitable for cleanrooms



- For side mounted applications
➤ Series R4-56 E4-1

Features & Benefits

- 1 KMA mounting brackets with attachment points on all sides
- 2 Very large gliding surfaces
- 3 Smooth, cable protecting inner chamber
- 4 Continuous glide surfaces
- 5 Interior stop dog
- 6 Small pitch for low-noise, smooth operation
- 7 Available with or without integrated profile rail
- 8 Can be shortened or lengthened due to modular design
- 9 No pin and bore connection
- 10 Fully enclosed E-Tube

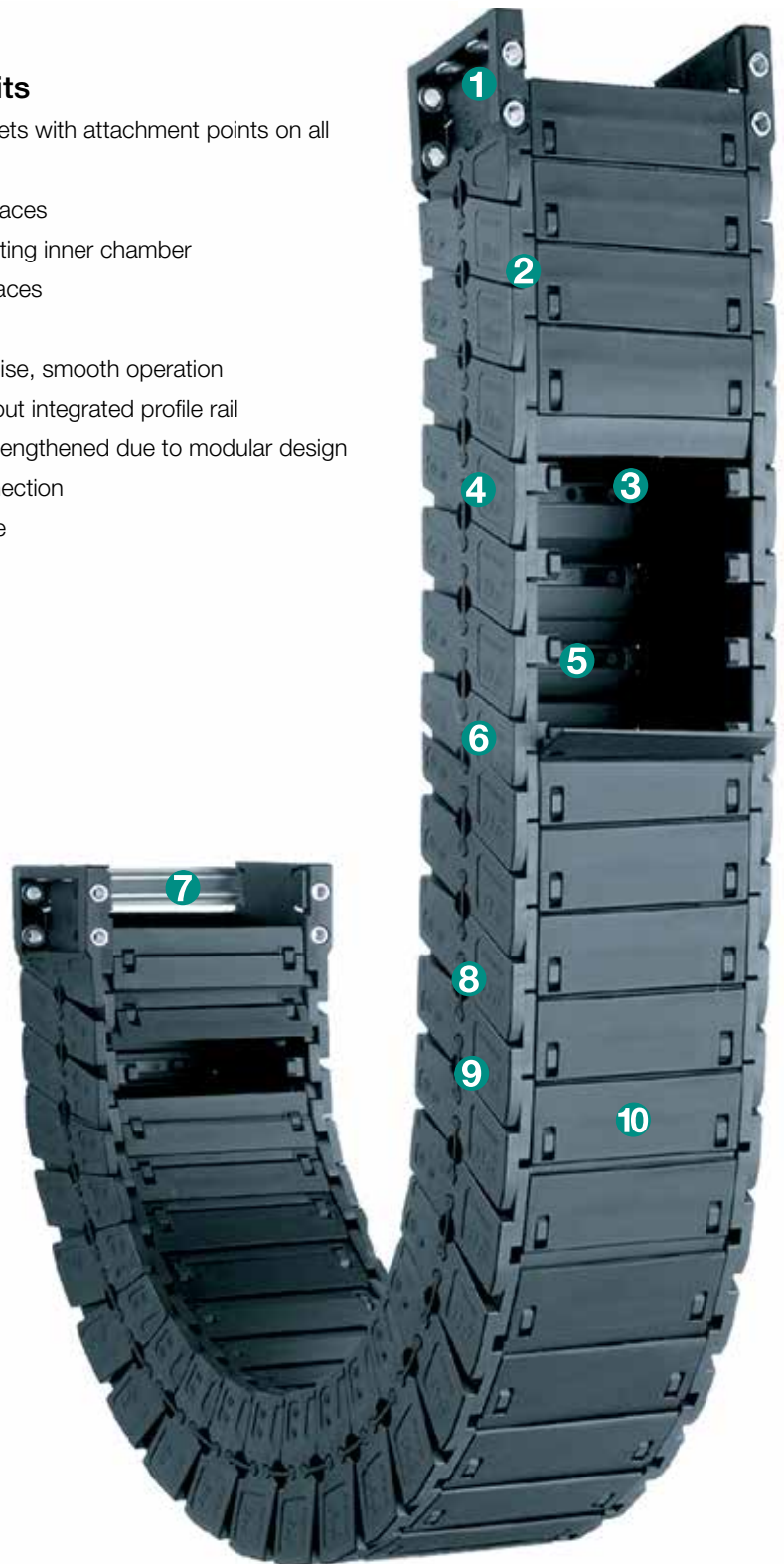

Order Example: Complete e-chain®

Please indicate chain length or number of links. Example:

6.56 ft (2 m) **R6-52-100-075-0**

e-chain®

With 2 separators **R6-52-11** assembled every 2nd link

Interior Separation

1 Set **R6-520-100-12**

Mounting Bracket

e-chain system® E6

Series R6-52

Installation Dimensions

Short travel, unsupported length

- FL_B = unsupported with permitted sag
 - FL_G = unsupported with straight upper run
- Further information ► Design, Chapter 1

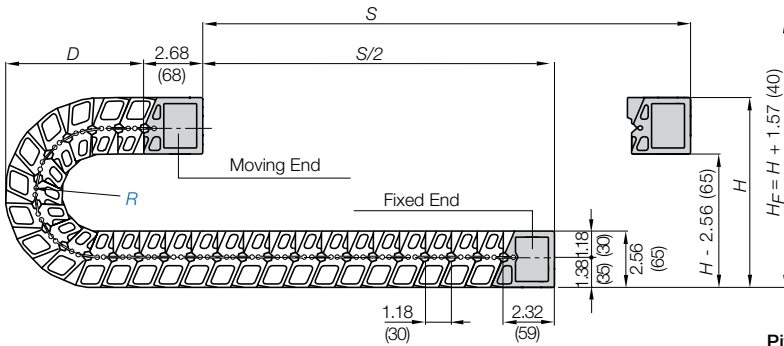
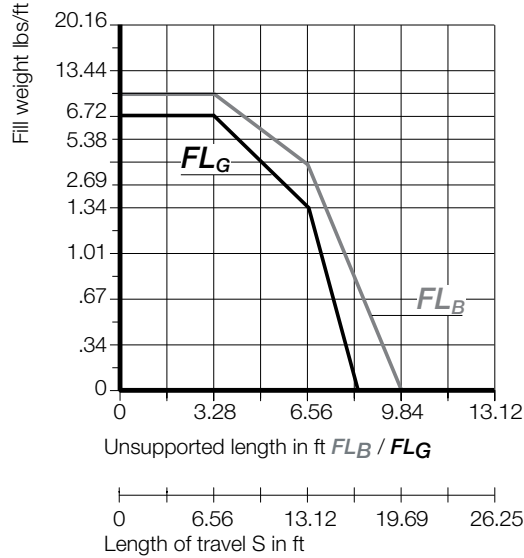
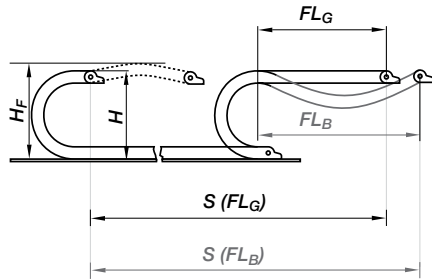

The required clearance height: $H_F = H + 1.57$ in. (40 mm) (with 1.34 lbs/ft (2.0 kg/m) fill weight. Please consult igus® if space is particularly restricted.

R	2.95 (075)	3.94 (100)	5.91 (150)	7.87 (200)	9.84 (250)
H	10.63 (270)	12.60 (320)	16.54 (420)	20.47 (520)	24.41 (620)
D	6.10 (155)	7.09 (180)	9.06 (230)	11.02 (280)	12.99 (330)
K	11.81 (300)	14.76 (375)	21.06 (535)	27.17 (690)	33.46 (850)

Pitch per link: = 1.18" (30 mm)

Links per ft (m): = 10.17 (34)

For center mount applications:

Chain length = $S/2 + K$

Short Travels - Unsupported



Unsupported e-chains® feature positive camber over short travels. This must be accounted for when specifying the clearance height. Please refer to **Installation dimensions** for further details.

Legend

- S = Length of travel
- R = Bending radius
- H = Nominal clearance height
- D = Overlength e-chain® radius in final position
- $K = \pi \cdot R + \text{safety buffer}$
- H_F = Required clearance height
- H_{in} = Trough inner height
- H_2 = *Mounting height
- D_2 = Overlength - long travels, gliding
- K_2 = *Add-on

*If the mounting bracket location is set lower

2.05

PDF: igus.com/e-chain-pdfs
Product information: igus.com/e-chains



Speed / acceleration FL_G	max. 65.6 ft/s (20 m/s) / max. 656 ft/s ² (200 m/s ²)
Speed / acceleration FL_B	max. 9.84 ft/s (3 m/s) / max. 19.69 ft/s ² (6 m/s ²)
Gliding speed / acceleration (maximum)	upon request
Permitted temperature	-40°F (-40°C) up to +158°F (+70° C)
Flammability Class	VDE 0304 IIC UL94 HB

Technical Data



Details of material properties

► Design, Chapter 1

Series R6-52 - e-chain® with lids

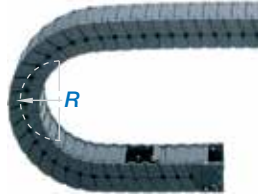
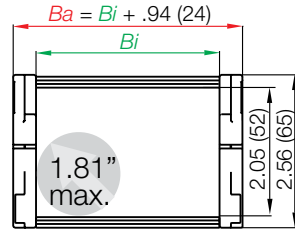

Part Number Structure



- Color - Black
- Bending radius
- Width
- Series

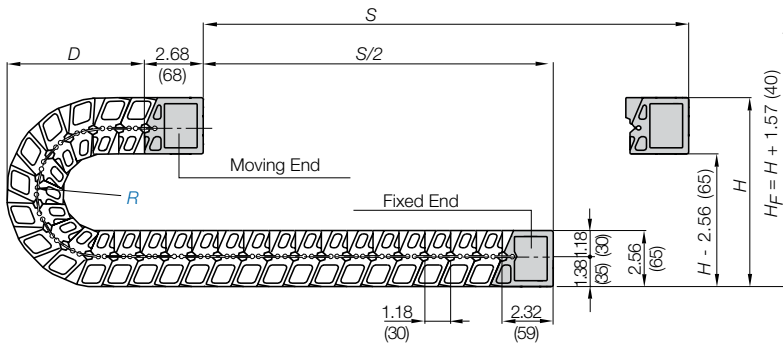

Supplement part number with required radius. Example: R6-52-100-075-0
Pitch: 1.18 in. (30 mm) per link links/ft (m) = 10.36 (34)

Part Number	Bi in. (mm)	Ba in. (mm)	Weight lbs/ft (kg/m)
R6-52-050- <input type="text"/> -0	1.97 (50)	2.91 (74)	≈1.27 (1.89)
R6-52-075- <input type="text"/> -0	2.95 (75)	3.90 (99)	≈1.42 (2.12)
R6-52-100- <input type="text"/> -0	3.94 (100)	4.88 (124)	≈1.58 (2.35)
R6-52-125- <input type="text"/> -0	4.92 (125)	5.87 (149)	≈1.73 (2.57)
R6-52-150- <input type="text"/> -0	5.91 (150)	6.85 (174)	≈1.88 (2.80)
R6-52-175- <input type="text"/> -0	6.89 (175)	7.83 (199)	≈2.04 (3.03)

Choose from the radii below for all of the above sizes
Radius (mm) Example: R6-52-100-075-0

	075	100	150	200	250
R	2.95 (75)	3.94 (100)	5.91 (150)	7.87 (200)	9.84 (250)
H	10.63 (270)	12.60 (320)	16.54 (420)	20.47 (520)	24.41 (620)
D	6.10 (155)	7.09 (180)	9.06 (230)	11.02 (280)	12.99 (330)
K	11.81 (300)	14.76 (375)	21.06 (535)	27.17 (690)	33.46 (850)

Option 1: Vertical separators

Vertical separators are used if a vertical subdivision of the e-chain® interior is required. By standard, vertical separators are assembled every other e-chain® link.

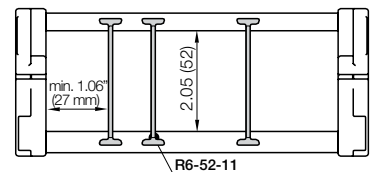

Vertical separator
R6-52-01

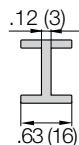

Vertical Separator

Unassembled Part No. R6-52-01

Assembled Part No. R6-52-11

- Vertical separator R6-52-01
This separator is used for general subdivision of E-Tubes.
- Separator snaps onto either the bottom of the carrier or the lid. Stays attached to that side. Opposite side can be removed.

e-chain system® E6

Series R6-52

Mounting Bracket



R6-52



Option 1: KMA - Pivoting

- Option - profile rail with integrated strain relief chainfix clip or tiwrap plates
- Profile rail can be mounted in the inner or outer radius of the e-chain®
- Bolted connection outside of the chain cross-section
- Recommended for unsupported applications (for gliding applications please contact igus®)
- Confined installation conditions
- Attachment capability on all sides

Moving end
R6-520...2

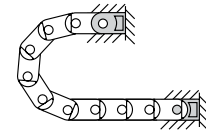
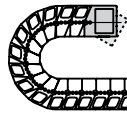

Possible installation configurations -

Fixed end
E6-520...1

Part Number Structure

R6-520-	040-	12	P
---------	------	----	---

With profile rail

Complete Set

Width

Mounting brackets for selected chain type

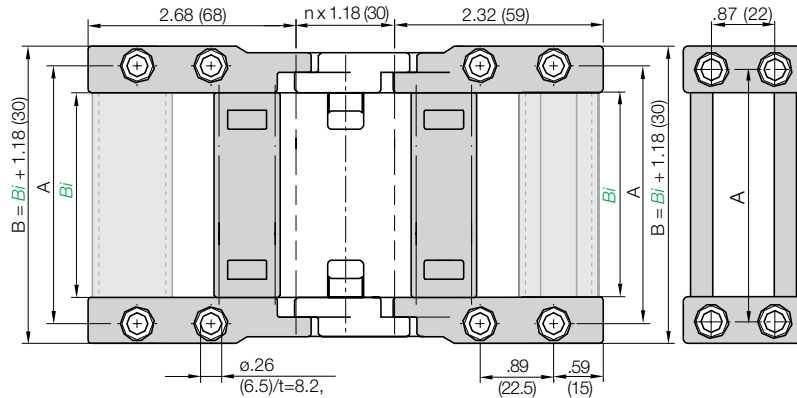

For Series	Part No. Full Set Without Profile Rail	Part No. Full Set With Profile Rail	Dimension A in. (mm)	Dimension B in. (mm)
R6-52-050	R6-520-050-12	R6-520-050-12P	2.60 (66)	3.15 (80)
R6-52-075	R6-520-075-12	R6-520-075-12P	3.58 (91)	4.13 (105)
R6-52-100	R6-520-100-12	R6-520-100-12P	4.57 (116)	5.12 (130)
R6-52-125	R6-520-125-12	R6-520-125-12P	5.55 (141)	6.10 (155)
R6-52-150	R6-520-150-12	R6-520-150-12P	6.54 (166)	7.09 (180)
R6-52-175	R6-520-175-12	R6-520-175-12P	7.52 (191)	8.07 (205)

Full set, for both ends:

R6-520- 040- 12 Full set, both fixed and moving end

Single-part order:

R6-520 - 040- 1

Mounting bracket fixed end

R6-520 - 040- 2

Mounting bracket moving end

Tiewrap Plates

Option 1: Tiewrap plates as an individual part

Available as an individual component, can be fixed onto a mounting bracket with the use of a profile rail.

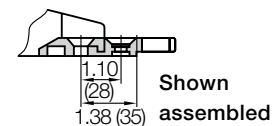

Shown assembled

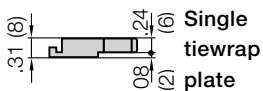

Single tiewrap plate

Tiewrap Plate	n Number of Teeth	C Overall Width in. (mm)	B Bore Width in. (mm)	Center Bore
3050-ZB	5	1.97 (50)	1.18 (30)	no
3075-ZB	7	2.95 (75)	2.16 (55)	no
3100-ZB	10	3.94 (100)	3.15 (80)	no
3115-ZB	11	4.53 (115)	3.74 (95)	no
3125-ZB	12	4.92 (125)	4.13 (105)	no
3150-ZB	15	5.91 (150)	5.12 (130)	no
3175-ZB	17	6.89 (175)	6.10 (155)	no
3200-ZB	20	7.87 (200)	7.09 (180)	yes
3225-ZB	22	8.86 (225)	8.07 (205)	yes
3250-ZB	25	9.84 (250)	9.06 (230)	yes

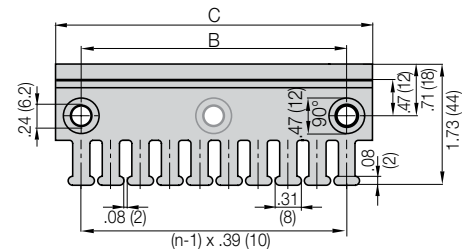

If used with KMA brackets with profile rail please add "KMA" to the end of the part number.

Example: 3050-ZBKMA

Other strain relief elements
► Strain Relief, Chapter 10

PDF: igus.com/e-chain-pdfs
Product information: igus.com/e-chains



Price Index

Series E6-62
Special Features / Options

Extremely low noise
 Test results upon request

IPA Certificate: Class 1, according to standard DIN EN ISO 14644-1 for the E6 system
 (Series E6-29-060-150-0-CR, (v = 1.64 ft/s, a = 3.28 ft/s²))

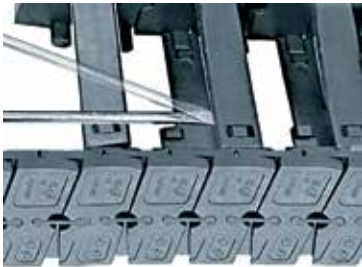
LEVEL 1 absorption confirmed by IPA-Fraunhofer-Institute according to SEMI E78-0998 for the E6 standard material
Assembly Tips

To close, push and click shut

Other Installation Methods

Vertical, hanging ≤ 196.8 ft (60 m)

Vertical, standing ≤ 9.84 ft (3 m)

Side-mounted, un supp. =

possible to a limited extent

Unsupported length of upper run upon request

Usage Guidelines



- If a low-noise version is required
- For very high speeds and/or accelerations
- If large stresses and thrust forces are present
- For small bending radii
- If less vibration is required
- Minimal abrasion, suitable for cleanrooms



- For side mounted applications
 - **Series E4-56 E4-1**
- For RBR (Reverse Bending Radius)
 - **Series E4-56 E4-1**
- For high additional loads
 - **Series E4-56 E4-1**
- For dirty environments
 - **Series E4-56 E4-1**

Features & Benefits

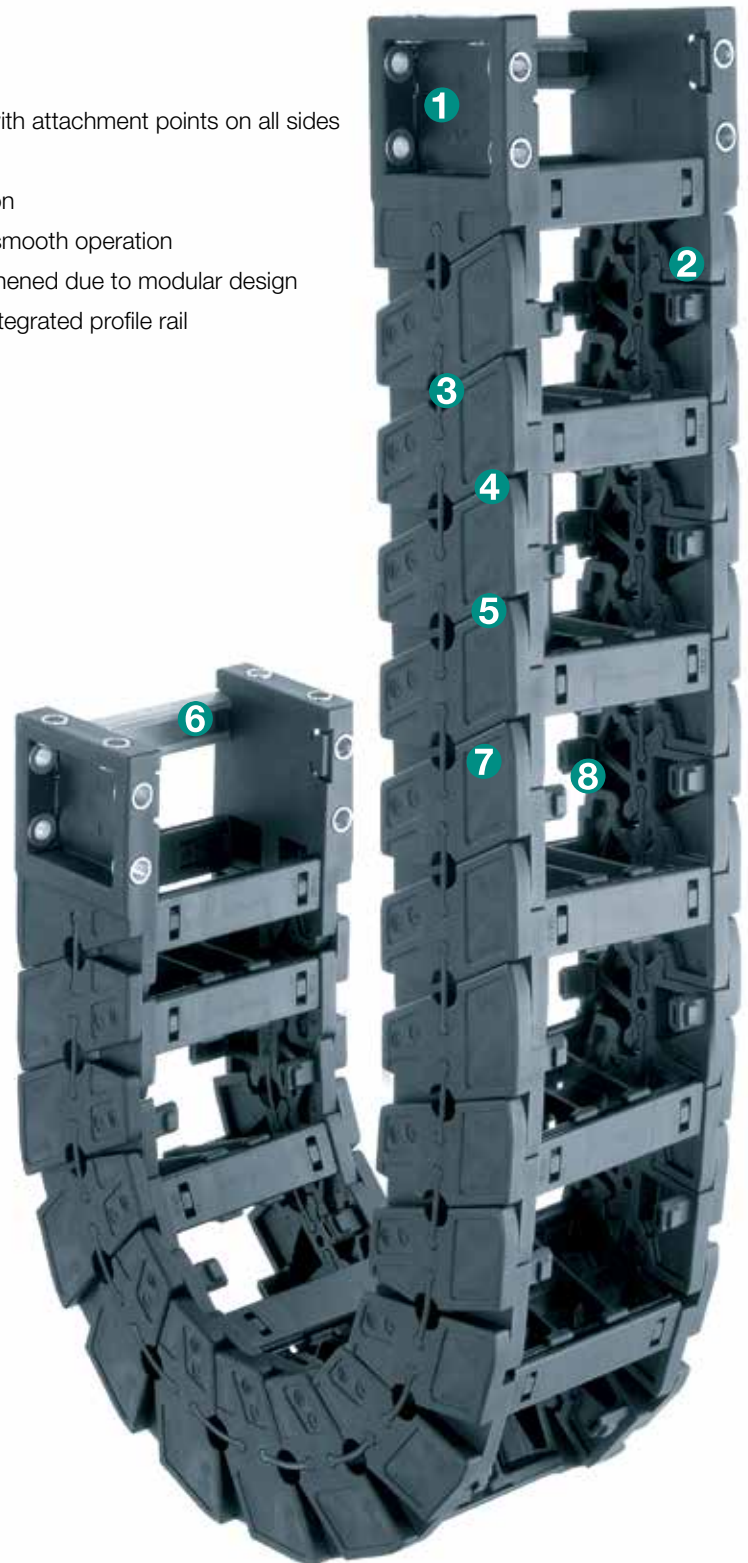
- 1 KMA mounting brackets with attachment points on all sides
- 2 Interior stop dog
- 3 No pin and bore connection
- 4 Small pitch for low-noise, smooth operation
- 5 Can be shortened or lengthened due to modular design
- 6 Available with or without integrated profile rail
- 7 Very large gliding surfaces
- 8 Increased inner height

Order Example: Complete e-chain®

Please indicate chain length or number of links. Example:

 6.56 ft (2 m) **E6-62-10-200-0**

e-chain®

 With 2 separators **E6-62-11** assembled every 2nd link

Interior Separation

 1 Set **E6-620-10-12P**

Mounting Bracket

e-chain system® E6

Series E6-62

Installation Dimensions

Short travel, unsupported length

- FL_B = unsupported with permitted sag
 - FL_G = unsupported with straight upper run
- Further information ► Design, Chapter 1

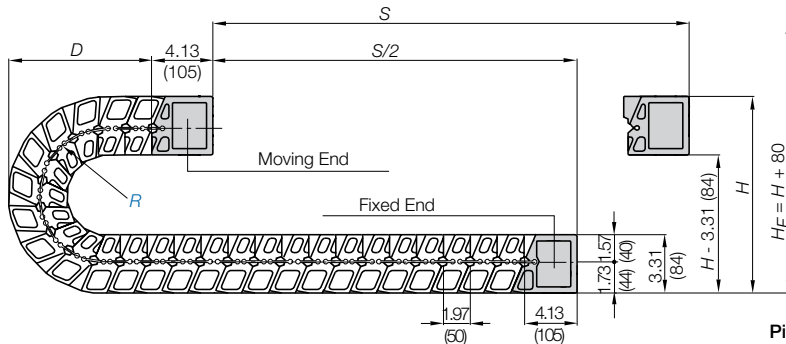
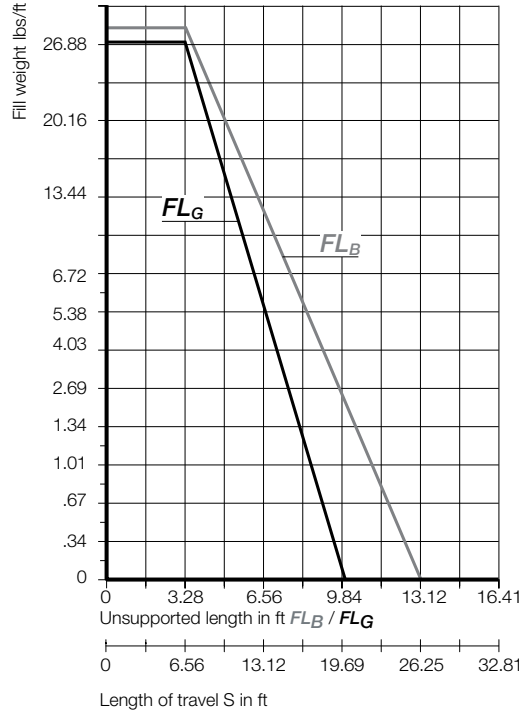
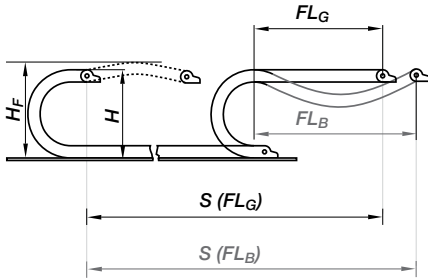

The required clearance height: $H_F = H + 3.15$ in. (80 mm) (with 1.34 lbs/ft (2.0 kg/m) fill weight. Please consult igus® if space is particularly restricted.

	4.53 (115)	5.91 (150)	7.87 (200)	9.84 (250)	11.81 (300)	13.78 (350)
R	4.53 (115)	5.91 (150)	7.87 (200)	9.84 (250)	11.81 (300)	13.78 (350)
H	15.28 (388)	18.03 (458)	21.97 (558)	25.91 (658)	29.84 (758)	33.78 (858)
D	9.21 (234)	10.59 (269)	12.56 (319)	14.53 (369)	16.50 (419)	18.46 (469)
K	18.31 (465)	22.64 (575)	28.74 (730)	35.04 (890)	41.14 (1045)	47.24 (1200)

Pitch per link = 1.97" (50 mm)

Links per ft (m) = 6.1 (20)

For center mount applications:

Chain length = $\frac{S}{2} + K$

Short Travels - Unsupported

2.44



Unsupported e-chains® feature positive camber over short travels. This must be accounted for when specifying the clearance height. Please refer to **Installation dimensions** for further details.

Legend

- S = Length of travel
- R = Bending radius
- H = Nominal clearance height
- D = Overlength e-chain® radius in final position
- $K = \pi \cdot R + \text{safety buffer}$
- H_F = Required clearance height
- H_{in} = Trough inner height
- H_2 = *Mounting height
- D_2 = Overlength - long travels, gliding
- K_2 = *Add-on

*If the mounting bracket location is set lower



Speed / acceleration FL_G	max. 65.6 ft/s (20 m/s) / max. 656 ft/s ² (200 m/s ²)
Speed / acceleration FL_B	max. 9.84 ft/s (3 m/s) / max. 19.69 ft/s ² (6 m/s ²)
Gliding speed / acceleration (maximum)	upon request
Permitted temperature	-40°F (-40°C) up to +158°F (+70° C)
Flammability Class	VDE 0304 IIC UL94 HB

Technical Data



Details of material properties

► Design, Chapter 1

Series E6-62 - e-chain® with crossbars every other link

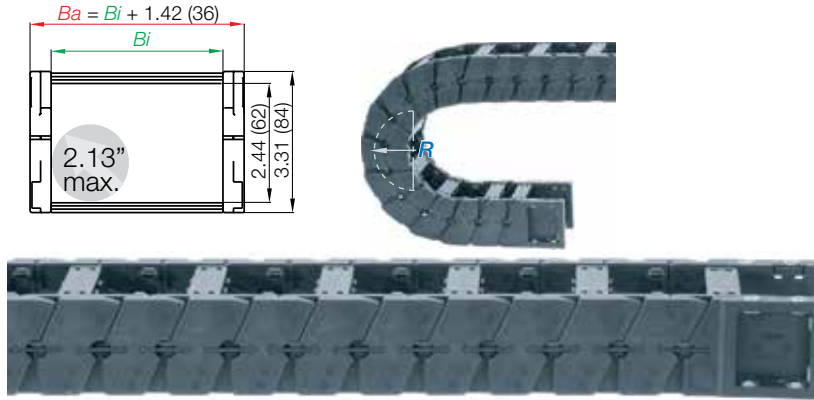

Part Number Structure

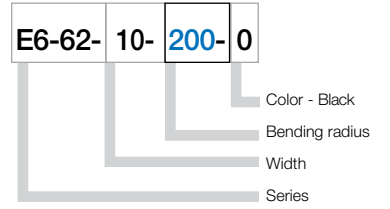

e-chain® as separate parts, links and side plates

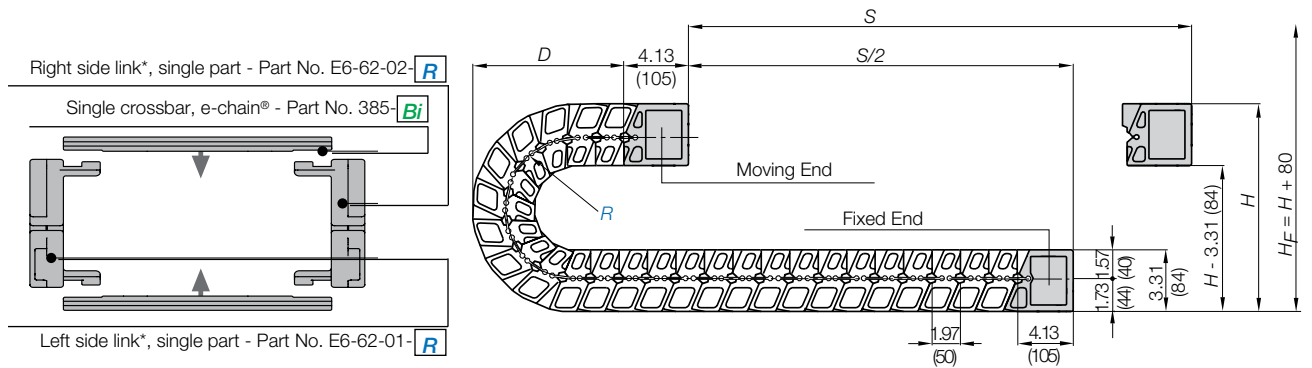

Polymer spring as single part -
Part No. E6-62-340

e-chain system® E6

Series E6-62



E6-62

Supplement part number with required radius. Example: E6-62-10-200-0
 Pitch: 1.97 in. (50 mm) per link links/ft (m) = 6.1 (20)

Part Number	Radius		Weight lbs/ft (kg/m)
	<i>Bi</i> in. (mm)	<i>Ba</i> in. (mm)	
E6-62-05- <input type="checkbox"/> -0	1.97 (50)	3.39 (86)	≈ 2.16 (3.22)
E6-62-06- <input type="checkbox"/> -0	2.67 (68)	4.09 (104)	≈ 2.20 (3.28)
E6-62-07- <input type="checkbox"/> -0	2.95 (75)	4.37 (111)	≈ 2.22 (3.31)
E6-62-087- <input type="checkbox"/> -0	3.43 (87)	4.84 (123)	≈ 2.25 (3.35)
E6-62-097- <input type="checkbox"/> -0	3.82 (97)	5.24 (133)	≈ 2.27 (3.38)
E6-62-10- <input type="checkbox"/> -0	3.94 (100)	5.35 (136)	≈ 2.28 (3.39)
E6-62-11- <input type="checkbox"/> -0	4.25 (108)	5.67 (144)	≈ 2.30 (3.42)
E6-62-112- <input type="checkbox"/> -0	4.41 (112)	5.83 (148)	≈ 2.30 (3.43)
E6-62-12- <input type="checkbox"/> -0	4.92 (125)	6.34 (161)	≈ 2.34 (3.48)
E6-62-137- <input type="checkbox"/> -0	5.39 (137)	6.81 (173)	≈ 2.37 (3.52)
E6-62-15- <input type="checkbox"/> -0	5.91 (150)	7.32 (186)	≈ 2.40 (3.57)
E6-62-162- <input type="checkbox"/> -0	6.38 (162)	7.80 (198)	≈ 2.43 (3.61)
E6-62-17- <input type="checkbox"/> -0	6.61 (168)	8.03 (204)	≈ 2.44 (3.63)
E6-62-18- <input type="checkbox"/> -0	6.89 (175)	8.31 (211)	≈ 2.45 (3.65)
E6-62-187- <input type="checkbox"/> -0	7.36 (187)	8.78 (223)	≈ 2.48 (3.69)
E6-62-20- <input type="checkbox"/> -0	7.87 (200)	9.29 (236)	≈ 2.51 (3.74)
E6-62-212- <input type="checkbox"/> -0	8.35 (212)	9.76 (248)	≈ 2.54 (3.78)
E6-62-23- <input type="checkbox"/> -0	8.86 (225)	10.28 (261)	≈ 2.57 (3.83)
E6-62-237- <input type="checkbox"/> -0	9.33 (237)	10.75 (273)	≈ 2.60 (3.87)
E6-62-25- <input type="checkbox"/> -0	9.84 (250)	11.26 (286)	≈ 2.63 (3.91)
E6-62-262- <input type="checkbox"/> -0	10.31 (262)	11.73 (298)	≈ 2.65 (3.95)
E6-62-28- <input type="checkbox"/> -0	10.83 (275)	12.24 (311)	≈ 2.69 (4.00)
E6-62-29- <input type="checkbox"/> -0	11.30 (287)	12.72 (323)	≈ 2.71 (4.04)
E6-62-30- <input type="checkbox"/> -0	11.81 (300)	13.23 (336)	≈ 2.75 (4.09)
E6-62-312- <input type="checkbox"/> -0	12.28 (312)	13.70 (348)	≈ 2.78 (4.13)
E6-62-325- <input type="checkbox"/> -0	12.80 (325)	14.21 (361)	≈ 2.80 (4.17)
E6-62-337- <input type="checkbox"/> -0	13.27 (337)	14.69 (373)	≈ 2.83 (4.21)
E6-62-350- <input type="checkbox"/> -0	13.78 (350)	15.20 (386)	≈ 2.86 (4.26)
E6-62-362- <input type="checkbox"/> -0	14.25 (362)	15.67 (398)	≈ 2.89 (4.30)
E6-62-375- <input type="checkbox"/> -0	14.76 (375)	16.18 (411)	≈ 2.92 (4.35)
E6-62-387- <input type="checkbox"/> -0	15.24 (387)	16.65 (423)	≈ 2.95 (4.39)
E6-62-400- <input type="checkbox"/> -0	15.75 (400)	17.16 (436)	≈ 2.98 (4.43)

Choose from the radii below for all of the above sizes

Radius (mm) Example: E6-62-10-200-0

	115	150	200	250	300	350
R	4.53 (115)	5.91 (150)	7.87 (200)	9.84 (250)	11.81 (300)	13.78 (350)
H	15.28 (388)	18.03 (458)	21.97 (558)	25.91 (658)	29.84 (758)	33.78 (858)
D	9.21 (234)	10.59 (269)	12.56 (319)	14.53 (369)	16.50 (419)	18.46 (469)
K	18.31 (465)	22.64 (575)	28.74 (730)	35.04 (890)	41.14 (1045)	47.24 (1200)

PDF: igus.com/e-chain-pdfs
 Product information: igus.com/e-chains



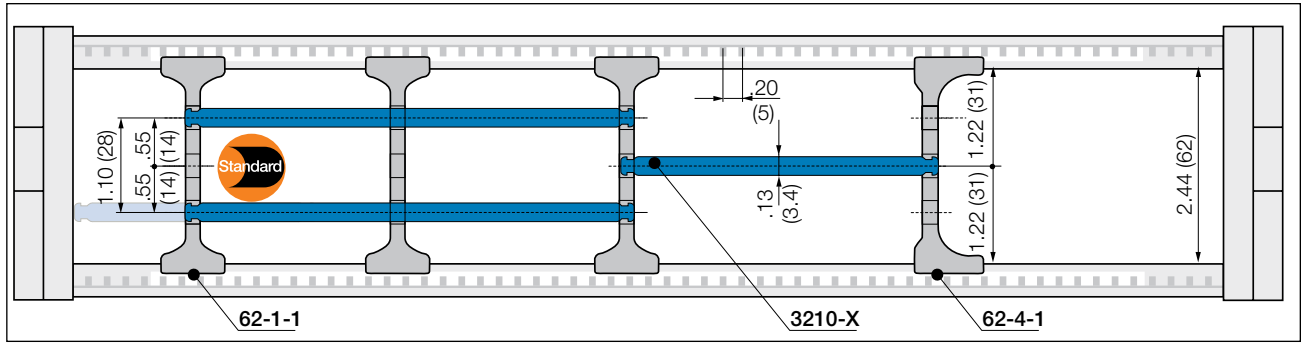

No lateral spacing between the separators and the side links is necessary.
 In the standard configuration separators are assembled every 2nd e-chain® link

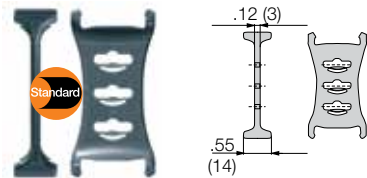

Separator, wide base

Unassembled	Part No. 62-1
Assembled	Part No. 62-1-1

- **Standard separator 62-1 for all applications**

Separator with wide base for maximum locking strength and safe standing in e-chains®.

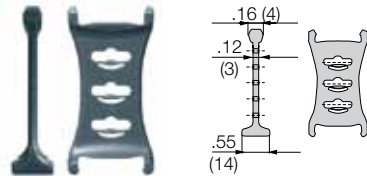

Separator for QuickLock crossbar

Unassembled	Part No. 62-2
Assembled	Part No. 62-2-1

- **Separator 62-2 For even faster installation**

Separator for QuickLock crossbar 385-X-Q. Firmly holds to one side with a wide base, narrow on opposite side for easy cable assembly (slight grip).

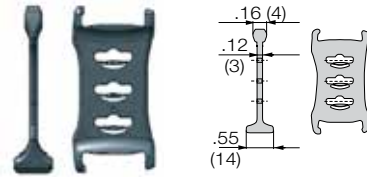

Notch separator for Notch crossbar

Unassembled	Part No. 62-5
Assembled	Part No. 62-5-1

- **Separator 62-5**

Locks safely in .20" (5mm) increments
 Notch separator for exact positioning in e-chains®. Recommended for side mounted applications.

Lockable full-width shelves - for the standard interior separation

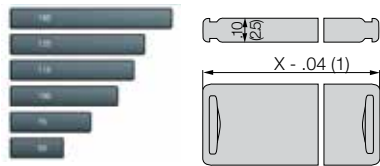

Full width shelf, lockable

Unassembled	Part No. 3200-X
Assembled	Part No. 3210-X

- **Full width shelf, lockable**

Shelf locks safely into separators on both ends, fixed width possible. Separators can be moved freely over the shelf horizontally. Can be arranged at three different heights.

Width X in. (mm)	Part No. Unassembled	Part No. Assembled	Width X in. (mm)	Part No. Unassembled	Part No. Assembled
1.97 (050)	3200-50	3210-50	5.91 (150)	3200-150	3210-150
2.95 (075)	3200-75	3210-75	6.89 (175)	3200-175	3210-175
3.94 (100)	3200-100	3210-100	7.87 (200)	3200-200	3210-200
4.53 (115)	3200-115	3210-115	8.86 (225)	3200-225	3210-225
4.92 (125)	3200-125	3210-125	9.84 (250)	3200-250	3210-250

e-chain system® E6

Series E6-62

Interior Separation - Previous Generation



E6-62

Option 1: Vertical separators and spacers

Vertical separators are used if a vertical subdivision of the e-chain® interior is required. By standard, vertical separators are assembled every other e-chain® link.

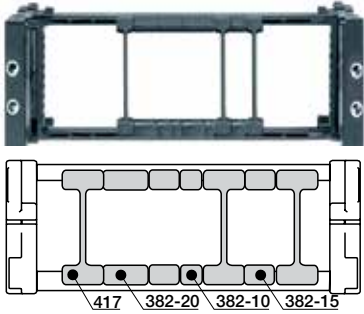

- Vertical separator**
 This separator is used for general subdivision of e-chains®.

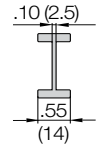

Vertical Separator	
Unassembled	Part No. 407
Assembled	Part No. 417

Spacer*

*For side-mounted applications



Unassembled	Part No. 381-XX
Assembled	Part No. 382-XX

XX = width of the spacer

Spacers available in the following sizes:

Part No. Unassembled	Part No. Assembled	in. (mm)
381 -10	382 -10	.39" (10)
381 -15	382 -15	.59" (15)
381 -20	382 -20	.79" (20)

Option 2: Full-width shelf

For applications involving many thin cables with similar or identical diameters. Vertical separator **E6-62-11** can be used in combination with full-width shelf **321-X**.

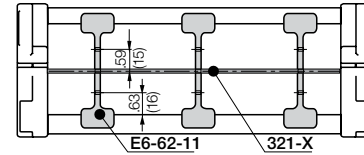

- Vertical separator, slotted**
 This separator is used for general subdivision of e-chains®.

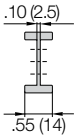

Vertical Separator	
Unassembled	Part No. E6-62-01
Assembled	Part No. E6-62-11

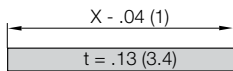

Width X in. (mm)	Part No. Unassem.	Part No. Assem.
1.97 (050)	320-50	321-50
2.68 (068)	320-68	321-68
2.95 (075)	320-75	321-75
3.43 (087)	320-87	321-87
3.94 (100)	320-100	321-100
4.25 (108)	320-108	321-108
4.41 (112)	320-112	321-112
4.92 (125)	320-125	321-125
5.39 (137)	320-137	321-137
5.91 (150)	320-150	321-150

Width X in. (mm)	Part No. Unassem.	Part No. Assem.
6.38 (162)	320-162	321-162
6.61 (168)	320-168	321-168
2.95 (175)	320-175	321-175
7.36 (187)	320-187	321-187
7.87 (200)	320-200	321-200
8.35 (212)	320-212	321-212
8.86 (225)	320-225	321-225
9.33 (237)	320-237	321-237
9.84 (250)	320-250	321-250

Option 3: Shelves

These components form the basic pattern of a shelf system. Shelves of various widths can be arranged at 7 different heights in .28" (7mm) increments

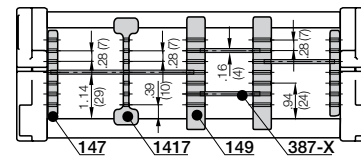

- Vertical separator**
 This separator is used when higher retention force is needed.

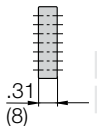

Vertical Separator	
Unassembled	Part No. 148
Assembled	Part No. 149

Width X in. (mm)	Part No. Unassembled	Part No. Assembled
.71 (18)	386-18	387-18
.91 (23)	386-23	387-23
.98 (25)	386-25	387-25
1.10 (28)	386-28	387-28
1.30 (33)	386-33	387-33
1.69 (43)	386-43	387-43
1.97 (50)	386-50	387-50
2.13 (54)	386-54	387-54
2.44 (62)	386-62	387-62

- Side plate**
 This separator is used for general subdivision of e-chains®.

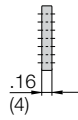

Side Plate	
Unassembled	Part No. 146
Assembled	Part No. 147

Width X in. (mm)	Part No. Unassembled	Part No. Assembled
2.95 (75)	386-75	387-75
3.43 (87)	386-87	387-87
3.94 (100)	386-100	387-100
4.25 (108)	386-108	387-108
4.92 (125)	386-125	387-125
5.91 (150)	386-150	387-150
6.89 (175)	386-175	387-175
7.87 (200)	386-200	387-200
8.19 (208)	386-208	387-208

- Vertical separator, slotted**
 This separator is used for general subdivision of e-chains®.

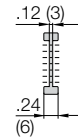

Vertical Separator, Slotted	
Unassembled	Part No. 1407
Assembled	Part No. 1417

Shelves 387-XX
 Shelf 387-XX can be used with vertical separator 149 and side plate 147

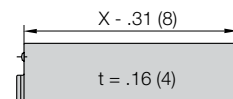

PDF: igus.com/e-chain-pdfs
 Product information: igus.com/e-chains





Option 1: KMA - Pivoting

- Option - profile rail with integrated strain relief chainfix clip or tiwrap plates
- Profile rail can be mounted in the inner or outer radius of the e-chain®
- Bolted connection outside of the chain cross-section
- Recommended for unsupported applications (for gliding applications please contact igus®)
- Confined installation conditions
- Attachment capability on all sides

Moving end
E6-620...2

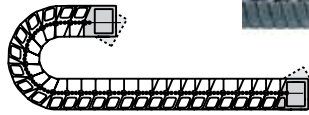

Fixed end
E6-620...1

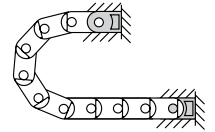

Possible installation configurations -

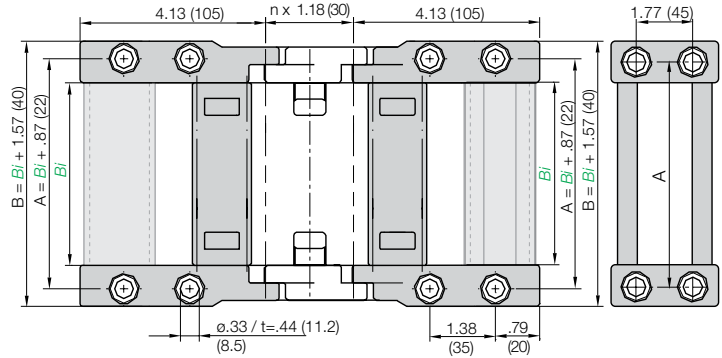

For Series	Part No. Full Set Without Profile Rail	Part No. Full Set With Profile Rail	Bi	
			in.	(mm)
E6-62-05	E6-620-05-12	E6-620-05-12P	1.97	(50)
E6-62-06	E6-620-06-12	E6-620-06-12P	2.67	(68)
E6-62-07	E6-620-07-12	E6-620-07-12P	2.95	(75)
E6-62-087	E6-620-087-12	E6-620-087-12P	3.43	(87)
E6-62-097	E6-620-097-12	E6-620-097-12P	3.82	(97)
E6-62-10	E6-620-10-12	E6-620-10-12P	3.94	(100)
E6-62-11	E6-620-11-12	E6-620-11-12P	4.25	(108)
E6-62-112	E6-620-112-12	E6-620-112-12P	4.41	(112)
E6-62-12	E6-620-12-12	E6-620-12-12P	4.92	(125)
E6-62-137	E6-620-137-12	E6-620-137-12P	5.39	(137)
E6-62-15	E6-620-15-12	E6-620-15-12P	5.91	(150)
E6-62-162	E6-620-162-12	E6-620-162-12P	6.38	(162)
E6-62-17	E6-620-17-12	E6-620-17-12P	6.61	(168)
E6-62-18	E6-620-18-12	E6-620-18-12P	6.89	(175)
E6-62-187	E6-620-187-12	E6-620-187-12P	7.36	(187)
E6-62-20	E6-620-20-12	E6-620-20-12P	7.87	(200)
E6-62-212	E6-620-212-12	E6-620-212-12P	8.35	(212)
E6-62-23	E6-620-23-12	E6-620-23-12P	8.86	(225)
E6-62-237	E6-620-237-12	E6-620-237-12P	9.33	(237)
E6-62-25	E6-620-25-12	E6-620-25-12P	9.84	(250)
E6-62-262	E6-620-262-12	E6-620-262-12P	10.31	(262)
E6-62-28	E6-620-28-12	E6-620-28-12P	10.83	(275)
E6-62-29	E6-620-29-12	E6-620-29-12P	11.30	(287)
E6-62-30	E6-620-30-12	E6-620-30-12P	11.81	(300)
E6-62-312	E6-620-312-12	E6-620-312-12P	12.28	(312)
E6-62-325	E6-620-325-12	E6-620-325-12P	12.80	(325)
E6-62-337	E6-620-337-12	E6-620-337-12P	13.27	(337)
E6-62-350	E6-620-350-12	E6-620-350-12P	13.78	(350)
E6-62-362	E6-620-362-12	E6-620-362-12P	14.25	(362)
E6-62-375	E6-620-375-12	E6-620-375-12P	14.76	(375)
E6-62-387	E6-620-387-12	E6-620-387-12P	15.24	(387)
E6-62-400	E6-620-400-12	E6-620-400-12P	15.75	(400)

Part Number Structure

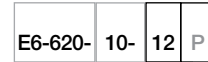

- With profile rail
- Complete Set
- Width
- Mounting brackets for selected chain type

Full set, for both ends:

E6-620-10-12 Full set, both fixed and moving end

Single-part order:

E6-620-10-1 Mounting bracket fixed end

E6-620-10-2 Mounting bracket moving end

Mounting bracket moving end



Adapters for gliding applications available upon request

Tiewrap Plates

Option 1:
Tiewrap plates as an individual part

Available as an individual component, can be fixed onto a mounting bracket with the use of a profile rail.

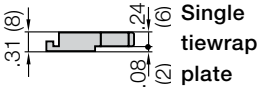
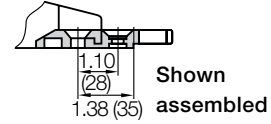

Tiewrap Plate	n Number of Teeth	C Overall Width in. (mm)	B Bore Width in. (mm)	Center Bore
3050-ZB	5	1.97 (50)	1.18 (30)	no
3075-ZB	7	2.95 (75)	2.16 (55)	no
3100-ZB	10	3.94 (100)	3.15 (80)	no
3115-ZB	11	4.53 (115)	3.74 (95)	no
3125-ZB	12	4.92 (125)	4.13 (105)	no
3150-ZB	15	5.91 (150)	5.12 (130)	no
3175-ZB	17	6.89 (175)	6.10 (155)	no
3200-ZB	20	7.87 (200)	7.09 (180)	yes
3225-ZB	22	8.86 (225)	8.07 (205)	yes
3250-ZB	25	9.84 (250)	9.06 (230)	yes

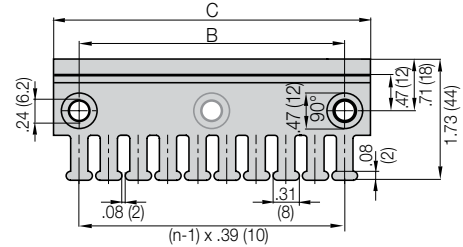

If used with KMA brackets with profile rail please add "KMA" to the end of the part number.

Example: 3050-ZBKMA

Other strain relief elements
► Strain Relief, Chapter 10



Price Index

Series E6-80

Special Features / Options



Extremely low noise
Test results upon request



IPA Certificate: Class 1, according
to standard DIN EN ISO 14644-1
for the E6 system
(Series E6-29-060-150-0-CR,
(v = 1.64 ft/s, a = 3.28 ft/s²)

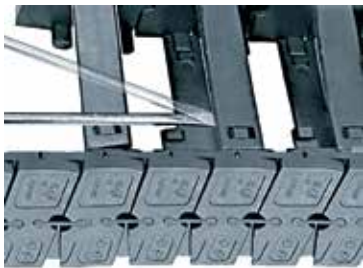

LEVEL 1 absorption confirmed
by IPA-Fraunhofer-Institute
according to SEMI E78-0998 for
the E6 standard material

Assembly Tips

To close, push and click shut

Other Installation Methods

Vertical, hanging ≤ 196.9 ft (60 m)

Vertical, standing ≤ 13.12 ft (4 m)

Side-mounted, un_supp. = possible to a
limited extentUnsupported length of upper run upon
request
Usage Guidelines



- If a low-noise version is required
- For very high speeds and/or accelerations
- If large stresses and thrust forces are present
- For small bending radii
- If less vibration is required
- Minimal abrasion, suitable for cleanrooms



- For side mounted applications
➤ **Series E4-80 E4-1**
- For RBR (Reverse Bending Radius)
➤ **Series E4-80 E4-1**
- For high additional loads
➤ **Series E4-80 E4-1**

Features & Benefits

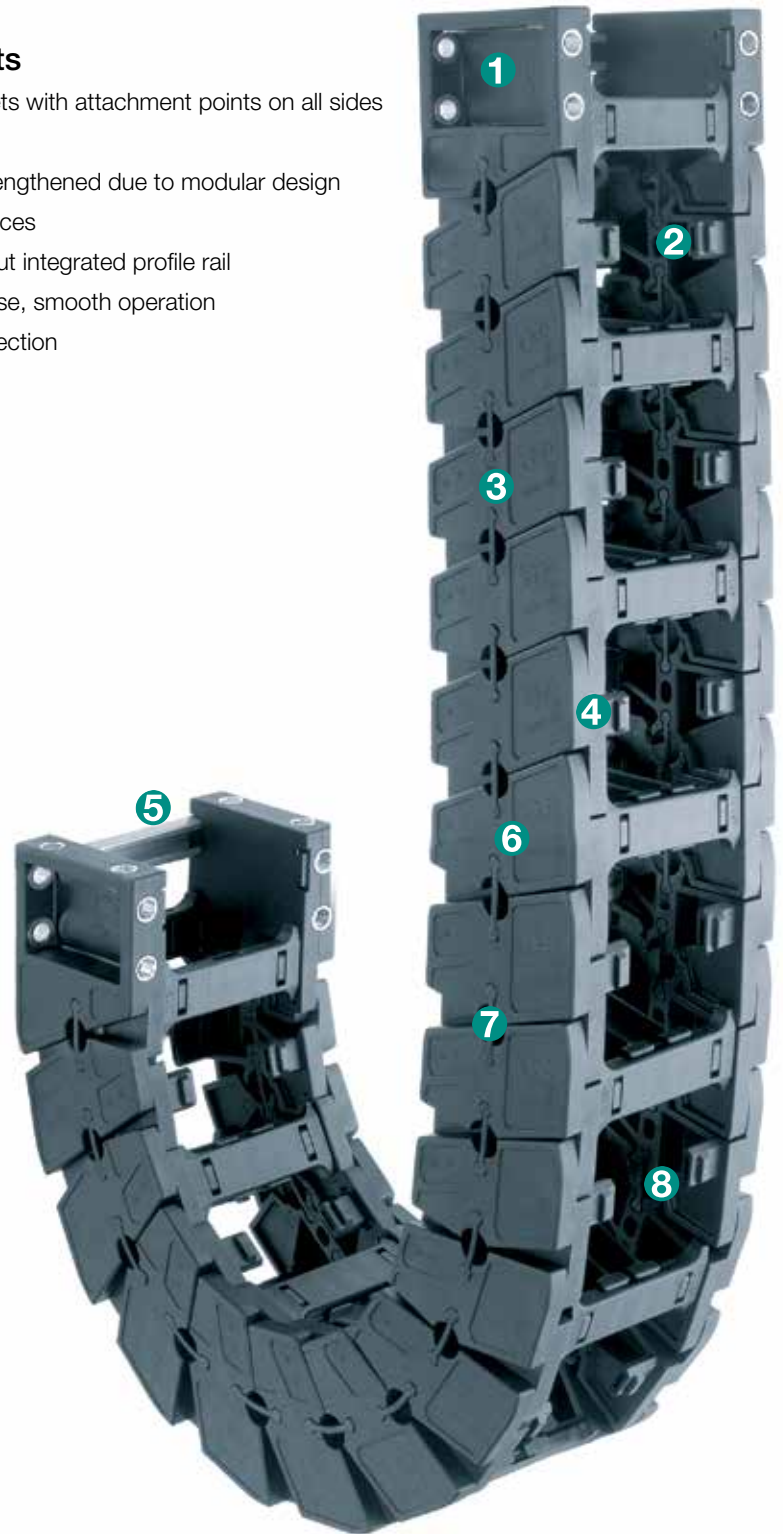
- 1 KMA mounting brackets with attachment points on all sides
- 2 Increased inner height
- 3 Can be shortened or lengthened due to modular design
- 4 Very large gliding surfaces
- 5 Available with or without integrated profile rail
- 6 Small pitch for low-noise, smooth operation
- 7 No pin and bore connection
- 8 Interior stop dog

Order Example: Complete e-chain®

Please indicate chain length or number of links. Example:

16.4 ft (5 m) **E6-80-10-200-0****e-chain®**With 2 separators **511** assembled every 2nd link**Interior Separation**1 Set **E6-800-10-12****Mounting Bracket**

e-chain system® E6

Series E6-80

Installation Dimensions

Short travel, unsupported length

- FL_B = unsupported with permitted sag
 - FL_G = unsupported with straight upper run
- Further information ► Design, Chapter 1

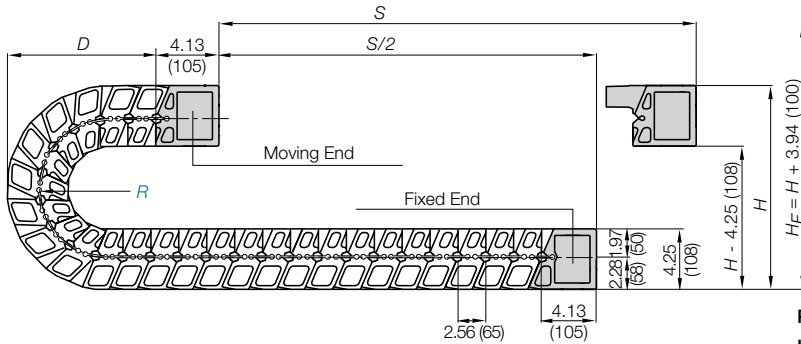
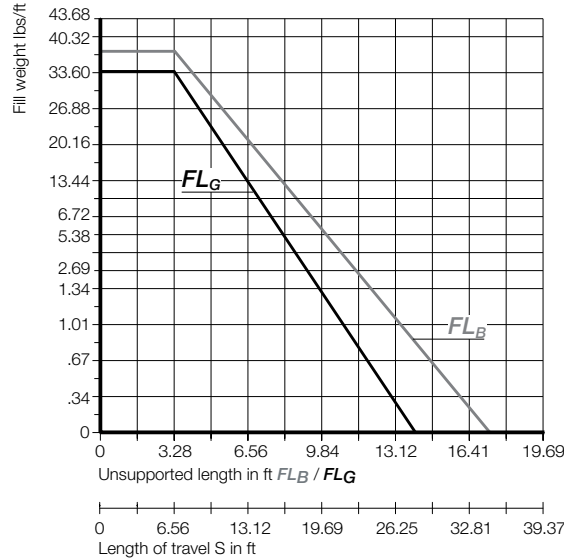
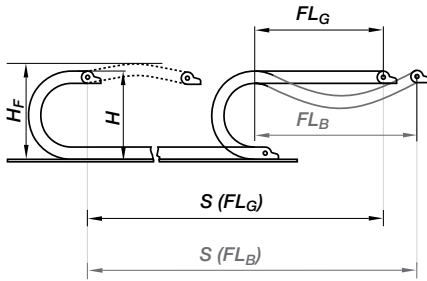

The required clearance height: $H_F = H + 3.94$ in. (100 mm) (with 3.36 lbs/ft (5.0 kg/m) fill weight). Please consult igus® if space is particularly restricted.

Pitch per link: = 2.56" (65 mm)
 Links per ft (m): = 4.68 (16)
 Chain length: = $\frac{S}{2} + K$

	5.91 (150)	7.87 (200)	9.84 (250)	11.81 (300)	13.78 (350)	15.75 (400)	17.71 (450)
R	5.91 (150)	7.87 (200)	9.84 (250)	11.81 (300)	13.78 (350)	15.75 (400)	17.71 (450)
H*	20.31 (516)	24.25 (616)	28.19 (716)	32.13 (816)	36.06 (916)	40.00 (1016)	43.94 (1116)
D	12.05 (306)	14.02 (356)	15.98 (406)	17.95 (456)	19.92 (506)	21.89 (556)	23.86 (606)
K	23.82 (605)	29.92 (760)	36.22 (920)	42.32 (1075)	48.43 (1230)	54.72 (1390)	60.83 (1545)



E6-80

Short Travels - Unsupported

3.15



Unsupported e-chains® feature positive camber over short travels. This must be accounted for when specifying the clearance height. Please refer to **Installation dimensions** for further details.

Legend

- S = Length of travel
- R = Bending radius
- H = Nominal clearance height
- D = Overlength e-chain® radius in final position
- $K = \pi \cdot R + \text{safety buffer}$
- H_F = Required clearance height
- H_{in} = Trough inner height
- H_2 = *Mounting height
- D_2 = Overlength - long travels, gliding
- K_2 = *Add-on

*If the mounting bracket location is set lower

PDF: igus.com/e-chain-pdfs
 Product information: igus.com/e-chains



Speed / acceleration FL_G	max. 65.6 ft/s (20 m/s) / max. 656 ft/s ² (200 m/s ²)
Speed / acceleration FL_B	max. 9.84 ft/s (3 m/s) / max. 19.69 ft/s ² (6 m/s ²)
Gliding speed / acceleration (maximum)	upon request
Permitted temperature	-40°F (-40°C) up to +158°F (+70°C)
Flammability Class	VDE 0304 IIC UL94 HB

Technical Data



Details of material properties

► Design, Chapter 1

7.116

Series E6-80 - e-chain® with crossbars every other link

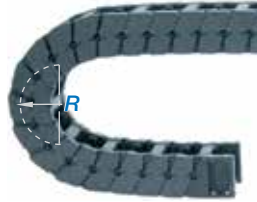
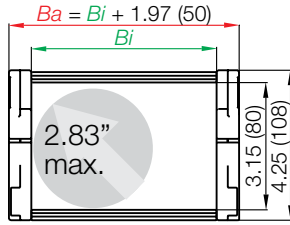

Part Number Structure

E6-80-	15-	175-	0
--------	-----	------	---

- Color - Black
- Bending radius
- Width
- Series



e-chain® as separate parts, side links and crossbars

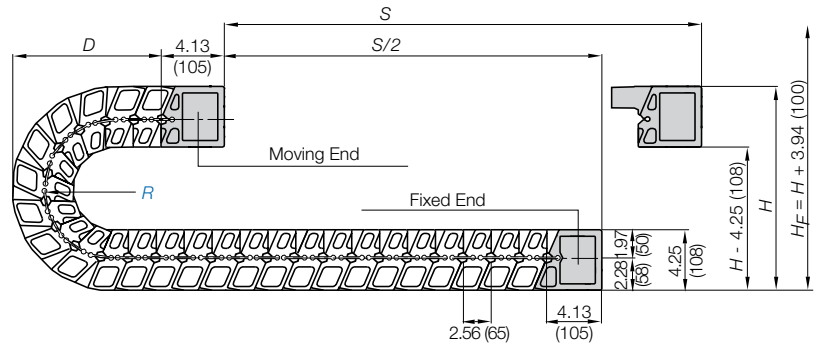
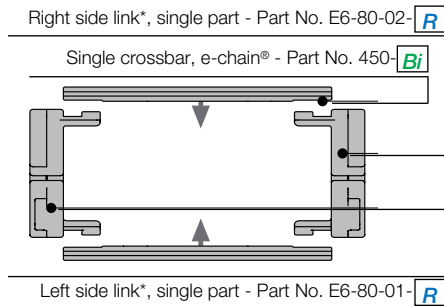

Polymer spring as single part - Part No. E6-80-350

*View from the fixed point of the e-chain®/E-Tube

e-chain system® E6

Series E6-80



E6-80

Supplement part number with required radius. Example: E6-80-10-200-0
Pitch: 2.56 in. (65 mm) per link links/ft (m) = 4.68 (16)

Part Number	<i>Bi</i>		<i>Ba</i>		Weight	
	in. (mm)		in. (mm)		lbs/ft (kg/m)	
E6-80-05- <input type="checkbox"/> -0	1.97 (50)	3.94 (100)	≈3.50 (5.21)			
E6-80-06- <input type="checkbox"/> -0	2.56 (65)	4.53 (115)	≈3.55 (5.28)			
E6-80-07- <input type="checkbox"/> -0	2.95 (75)	4.92 (125)	≈3.58 (5.33)			
E6-80-08- <input type="checkbox"/> -0	3.43 (87)	5.91 (137)	≈3.62 (5.38)			
E6-80-10- <input type="checkbox"/> -0	3.94 (100)	5.91 (150)	≈3.66 (5.45)			
E6-80-11- <input type="checkbox"/> -0	4.41 (112)	6.38 (162)	≈3.70 (5.50)			
E6-80-12- <input type="checkbox"/> -0	4.92 (125)	6.89 (175)	≈3.74 (5.57)			
E6-80-13- <input type="checkbox"/> -0	5.39 (137)	7.36 (187)	≈3.78 (5.62)			
E6-80-15- <input type="checkbox"/> -0	5.91 (150)	7.87 (200)	≈3.82 (5.68)			
E6-80-16- <input type="checkbox"/> -0	6.38 (162)	8.35 (212)	≈3.86 (5.74)			
E6-80-17- <input type="checkbox"/> -0	6.89 (175)	8.86 (225)	≈3.90 (5.80)			
E6-80-18- <input type="checkbox"/> -0	7.36 (187)	9.33 (237)	≈3.94 (5.86)			
E6-80-20- <input type="checkbox"/> -0	7.87 (200)	9.84 (250)	≈3.98 (5.92)			
E6-80-21- <input type="checkbox"/> -0	8.35 (212)	10.31 (262)	≈4.02 (5.98)			
E6-80-22- <input type="checkbox"/> -0	8.86 (225)	10.83 (275)	≈4.06 (6.04)			
E6-80-23- <input type="checkbox"/> -0	9.33 (237)	11.30 (287)	≈4.10 (6.10)			
E6-80-25- <input type="checkbox"/> -0	9.84 (250)	11.81 (300)	≈4.14 (6.16)			
E6-80-26- <input type="checkbox"/> -0	10.31 (262)	12.28 (312)	≈4.17 (6.21)			
E6-80-27- <input type="checkbox"/> -0	10.83 (275)	12.80 (325)	≈4.22 (6.28)			
E6-80-28- <input type="checkbox"/> -0	11.30 (287)	13.27 (337)	≈4.25 (6.33)			
E6-80-30- <input type="checkbox"/> -0	11.81 (300)	13.78 (350)	≈4.29 (6.39)			
E6-80-31- <input type="checkbox"/> -0	12.28 (312)	14.25 (362)	≈4.33 (6.45)			
E6-80-32- <input type="checkbox"/> -0	12.80 (325)	14.76 (375)	≈4.37 (6.51)			
E6-80-33- <input type="checkbox"/> -0	13.27 (337)	15.24 (387)	≈4.41 (6.57)			
E6-80-35- <input type="checkbox"/> -0	13.78 (350)	15.75 (400)	≈4.46 (6.63)			
E6-80-36- <input type="checkbox"/> -0	14.25 (362)	16.22 (412)	≈4.50 (6.69)			
E6-80-37- <input type="checkbox"/> -0	14.76 (375)	16.73 (425)	≈4.54 (6.75)			
E6-80-38- <input type="checkbox"/> -0	15.24 (387)	17.20 (437)	≈4.57 (6.80)			
E6-80-40- <input type="checkbox"/> -0	15.75 (400)	17.72 (450)	≈4.62 (6.88)			
E6-80-41- <input type="checkbox"/> -0	16.22 (412)	18.19 (462)	≈4.65 (6.92)			
E6-80-42- <input type="checkbox"/> -0	16.73 (425)	18.70 (475)	≈4.70 (6.99)			
E6-80-43- <input type="checkbox"/> -0	17.20 (437)	19.17 (487)	≈4.73 (7.04)			
E6-80-45- <input type="checkbox"/> -0	17.72 (450)	19.69 (500)	≈4.77 (7.10)			
E6-80-46- <input type="checkbox"/> -0	18.19 (462)	20.16 (512)	≈4.81 (7.16)			
E6-80-47- <input type="checkbox"/> -0	18.70 (475)	20.67 (525)	≈4.85 (7.22)			
E6-80-48- <input type="checkbox"/> -0	19.17 (487)	21.14 (537)	≈4.89 (7.28)			
E6-80-50- <input type="checkbox"/> -0	19.69 (500)	21.65 (550)	≈4.93 (7.34)			
E6-80-51- <input type="checkbox"/> -0	20.16 (512)	22.13 (562)	≈4.97 (7.40)			
E6-80-52- <input type="checkbox"/> -0	20.67 (525)	22.64 (575)	≈5.01 (7.46)			
E6-80-53- <input type="checkbox"/> -0	21.14 (537)	23.11 (587)	≈5.05 (7.52)			
E6-80-55- <input type="checkbox"/> -0	21.65 (550)	23.62 (600)	≈5.09 (7.58)			
E6-80-60- <input type="checkbox"/> -0	23.62 (600)	25.59 (650)	≈5.25 (7.81)			

Choose from the radii below for all of the above sizes
Radius (mm) Example: E6-80-10-200-0

	150	200	250	300	350	400	450
R	5.91 (150)	7.87 (200)	9.84 (250)	11.81 (300)	13.78 (350)	15.75 (400)	17.71 (450)
H*	20.31 (516)	24.25 (616)	28.19 (716)	32.13 (816)	36.06 (916)	40.00 (1016)	43.94 (1116)
D	12.05 (306)	14.02 (356)	15.98 (406)	17.95 (456)	19.92 (506)	21.89 (556)	23.86 (606)
K	23.82 (605)	29.92 (760)	36.22 (920)	42.32 (1075)	48.43 (1230)	54.72 (1390)	60.82 (1545)

PDF: igus.com/e-chain-pdfs
Product information: igus.com/e-chains



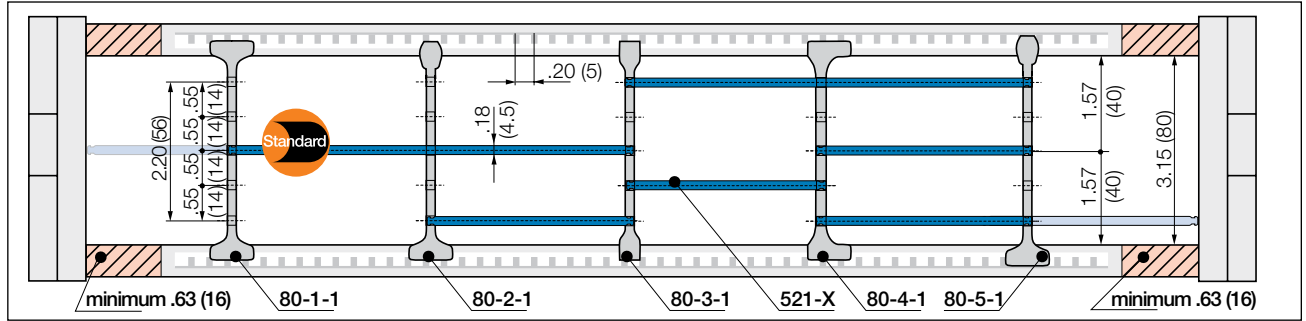

Note: Please maintain a lateral spacing of .63" (16 mm) between the separators and the side links.
In the standard configuration separators are assembled every 2nd e-chain® link

Telephone 1-800-521-2747

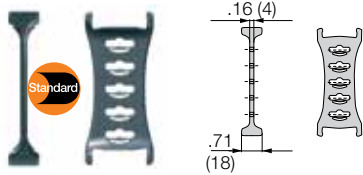

Separator, wide base

Unassembled	Part No. 80-1
Assembled	Part No. 80-1-1

- **Standard separator 80-1 for all applications**
Separator with wide base for maximum locking strength and safe standing in e-chains®.

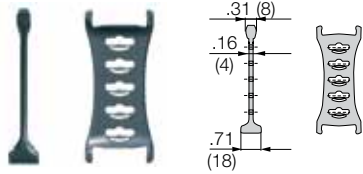

Separator for QuickLock crossbar

Unassembled	Part No. 80-2
Assembled	Part No. 80-2-1

- **Separator 80-2 For even faster installation**
Separator for QuickLock crossbar 385-X-Q. Firmly holds to one side with a wide base, narrow on opposite side for easy cable assembly (slight grip).

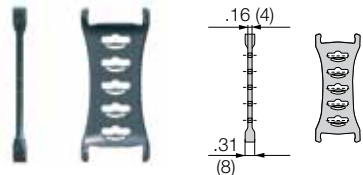

Separator, narrow base

Unassembled	Part No. 80-3
Assembled	Part No. 80-3-1

- **Separator 80-3 For many thin cables**
Separator with a narrow base for a large number of thin cables side by side. Save space in e-chains®.

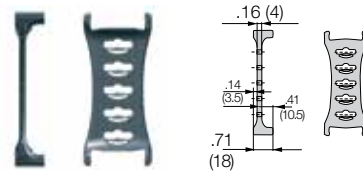

Separator, asymmetrical

Unassembled	Part No. 80-4
Assembled	Part No. 80-4-1

- **Separator 80-4 For side-mounted applications**
Asymmetrical separator, for defined distance. No additional spacers necessary.

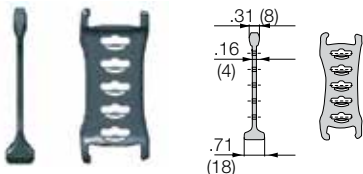

Notch separator for Notch crossbar

Unassembled	Part No. 80-5
Assembled	Part No. 80-5-1

- **Separator 80-5 Locks safely in .20" (5mm) increments**
Notch separator for exact positioning in e-chains®. Recommended for side mounted applications.

Lockable full-width shelves - for the standard interior separation

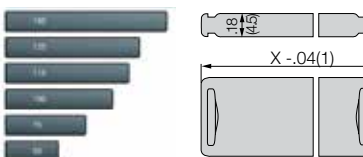

Full width shelf, lockable

Unassembled	Part No. 520-X
Assembled	Part No. 521-X

- **Full width shelf, lockable**
Shelf locks safely into separators on both ends, fixed width possible. Separators can be moved freely over the shelf horizontally. Can be arranged at three different heights.

Internet: igus.com
email: sales@igus.com
QuickSpec: igus.com/quickspec

Width X in. (mm)	Part No. Unassembled	Part No. Assembled	Width X in. (mm)	Part No. Unassembled	Part No. Assembled	Width X in. (mm)	Part No. Unassembled	Part No. Assembled
1.97 (050)	520-050	521-050	5.91 (150)	520-150	521-150	11.81 (300)	520-300	521-300
2.55 (065)	520-065	521-065	6.89 (175)	520-175	521-175	13.78 (350)	520-350	521-350
2.95 (075)	520-075	521-075	7.87 (200)	520-200	521-200	14.76 (375)	520-375	521-375
3.94 (100)	520-100	521-100	8.86 (225)	520-225	521-225	15.24 (387)	520-387	521-387
4.92 (125)	520-125	521-125	9.84 (250)	520-250	521-250	17.72 (450)	520-450	521-450

e-chain system® E6
 Series E6-80
 Interior Separation - Previous Generation



E6-80



Option 1: Vertical separators and spacers

Vertical separators are used if a vertical subdivision of the e-chain® interior is required. By standard, vertical separators are assembled every other e-chain® link.

NOTE: Observe a lateral spacing of at least 1.30 in. (33mm) for E-Tubes and .63 in. (16mm) for e-chain®. There is no minimum spacing needed for side plates

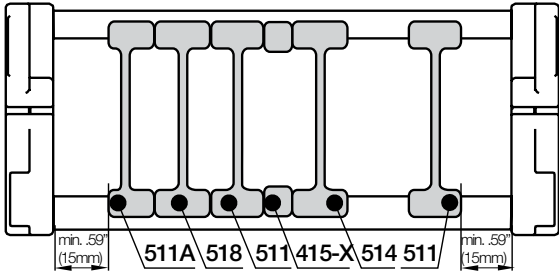

Vertical separator
501

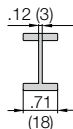

Vertical separator

Unassembled	Part No. 501
Assembled	Part No. 511

• **Standard separator 501**

This separator offers safe stability due to its wide base design, also when used with thick cables or hoses.



Locking separator
504



Locking separator

Unassembled	Part No. 504
Assembled	Part No. 514

• **Locking separator 504**

This separator features increased retention force for applications exposed to very high humidity and extreme loads. If locking separators are used, the e-chain® is more difficult to open.



Locking separator
508



Locking separator

Unassembled	Part No. 508
Assembled	Part No. 518

• **Locking separator 508**

This separator is used for applications that are exposed to extremely high humidity. The clamp at the side serves to uniformly align the separators. In order to avoid destroying the separators when opening the e-chain®, make sure all separators are identically aligned.



Asymmetric separator
501A

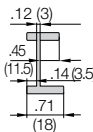

Asymmetrical separator

Unassembled	Part No. 501A
Assembled	Part No. 511A

• **Asymmetrical separator 501A**

This separator features an (18mm) base. It can be used in combinations between spacers of different widths and vertical separators in side mounted applications.



Spacers
405-XX



Spacer

Unassembled	Part No. 405-XX
Assembled	Part No. 415-XX

XX = width of the spacer

• **NOTE ON SPACERS**

Vertical separators are adjustable, but can be fixed in position by means of a spacer. Spacers are most often necessary for side mounted applications. The available inner height is reduced by .08" (2mm) **per spacer** (for example if one spacer is placed on either side of the separator, the overall inner height is reduced by .16" (4mm). To avoid this, place the spacers on the **outside** of the opening crossbar (**not for long travels**).

Spacers available in the following sizes:

Part No. Unassembled	Part No. Assembled	in.	(mm)
405 -10	415 -10	.39"	(10)
405 -15	415 -15	.59"	(15)
405 -20	415 -20	.79"	(20)
405 -30	415 -30	1.18"	(30)
405 -40	415 -40	1.57"	(40)



PDF: igus.com/e-chain-pdfs
 Product information: igus.com/e-chains

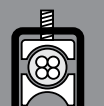



Option 2: Shelves

e-chains® and E-Tubes can be subdivided both vertically and horizontally using the various interior separation elements.

► **Design, Chapter 1** for layout recommendations.

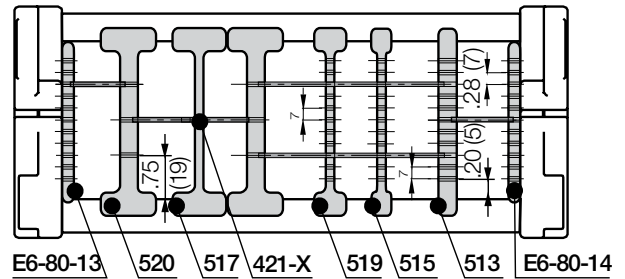

- **Side plates E6-80-03/E6-80-04**
This component is used to form the basic pattern of a shelf system.

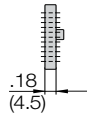

Side plate (left)

Unassembled **Part No. E6-80-03**

Assembled **Part No. E6-80-13**

Side plate (right)

Unassembled **Part No. E6-80-04**

Assembled **Part No. E6-80-14**

Side plate

E6-80-03 (left)

E6-80-04 (right)

- **Vertical separator 503**
This component is used to form the basic pattern of a shelf system.

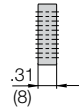

Vertical separator

Unassembled **Part No. 503**

Assembled **Part No. 513**

Vertical separator

503



- **Locking separator, slotted 507**
This separator features increased retention force for applications exposed to very high humidity and extreme loads. The extra retention force is achieved by asymmetric claws for the crossbar. Take care to ensure proper alignment.

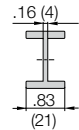

Locking separator, slotted

Unassembled **Part No. 507**

Assembled **Part No. 517**

Locking separator,

slotted

507



- **Locking vertical separator 510**
This separator is slotted and able to be combined with shelves.

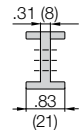

Locking vertical separator

Unassembled **Part No. 510**

Assembled **Part No. 520**

Locking vertical

separator

510



- **Slotted separators 505**
These are used for very complex subdivisions. However, they cannot be retrofitted into an existing separation system without removing the shelves first.

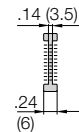

Slotted separators, closed

Unassembled **Part No. 505**

Assembled **Part No. 515**

Closed slotted

separator

505



- **Slotted separator 509**
This separator can be retrofitted into an existing interior separation system without removing the shelves, as long as these shelves fit into any of the 7 middle slots

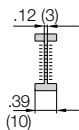

Slotted separators, open

Unassembled **Part No. 509**

Assembled **Part No. 519**

Open slotted

separator

509



Shelves 420-XX

These components form the basic pattern of a shelf system. Shelves of various widths can be arranged at 11 different heights in .28" (7mm) increments

Width X in.(mm)	Usable Width in.	Part No. Unassembled (mm)	Part No. Assembled	Width X in. (mm)	Usable Width in. (mm)	Part No. Unassembled	Part No. Assembled
.71 (18)	.39 (10)	420-18	421-18	2.95 (75)	2.64 (67)	420-75	421-75
.91 (23)	.59 (15)	420-23	421-23	3.46 (88)	3.15 (80)	420-88	421-88
.98 (25)	.67 (17)	420-25	421-25	3.94 (100)	3.62 (92)	420-100	421-100
1.10 (28)	.79 (20)	420-28	421-28	4.92 (125)	4.61 (117)	420-125	421-125
1.30 (33)	.98 (25)	420-33	421-33	5.91 (150)	5.59 (142)	420-150	421-150
1.69 (43)	1.38 (35)	420-43	421-43	6.89 (175)	6.57 (167)	420-175	421-175
1.97 (50)	1.65 (42)	420-50	421-50	7.36 (187)	7.05 (179)	420-187	421-187
2.44 (62)	2.13 (54)	420-62	421-62	7.87 (200)	7.56 (192)	420-200	421-200

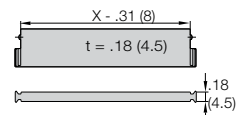

e-chain system® E6

Series E6-80

Mounting Brackets - KMA



E6-80



Option 1: KMA - Pivoting

- Option - profile rail with integrated strain relief chainfix clip or tiwrap plates
- Profile rail can be mounted in the inner or outer radius of the e-chain®
- Bolted connection outside of the chain cross-section
- Recommended for unsupported applications
- Confined installation conditions
- Attachment capability on all sides

Moving end
E6-800...2

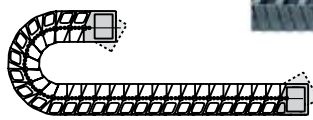

Fixed end
E6-800...1

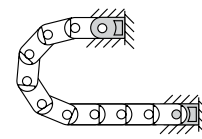

Possible installation configurations -

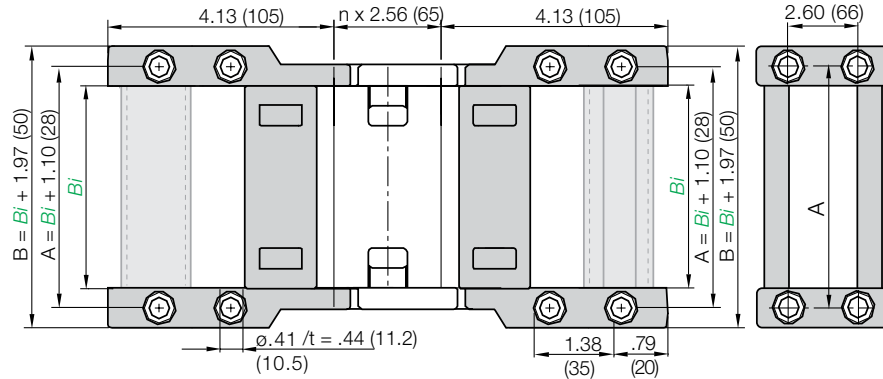

Part Number Structure

E6-800-	05-	12	P
---------	-----	----	---

With profile rail

Complete Set

Width

Mounting brackets for selected chain type

Full set, for both ends:

E6-800- 05- 12 Full set,

both fixed and moving end

Single-part order:

E6-800- 05- 1

Mounting bracket fixed end

E6-800- 05- 2

Mounting bracket moving end



Adapters for gliding applications available upon request

For Series	Part No. Full Set W/O Profile Rail	Part No. Full Set With Profile Rail	B_i in.	B_i (mm)	For Series	Part No. Full Set W/O Profile Rail	Part No. Full Set With Profile Rail	B_i in.	B_i (mm)
E6-80-05	E6-800-05-12	E6-800-05-12P	1.97	(50)	E6-80-31	E6-800-31-12	E6-800-31-12P	12.28	(312)
E6-80-06	E6-800-06-12	E6-800-06-12P	2.56	(65)	E6-80-32	E6-800-32-12	E6-800-32-12P	12.80	(325)
E6-80-07	E6-800-07-12	E6-800-07-12P	2.95	(75)	E6-80-33	E6-800-33-12	E6-800-33-12P	13.27	(337)
E6-80-08	E6-800-08-12	E6-800-08-12P	3.43	(87)	E6-80-35	E6-800-35-12	E6-800-35-12P	13.78	(350)
E6-80-10	E6-800-10-12	E6-800-10-12P	3.94	(100)	E6-80-36	E6-800-36-12	E6-800-36-12P	14.25	(362)
E6-80-11	E6-800-11-12	E6-800-11-12P	4.41	(112)	E6-80-37	E6-800-37-12	E6-800-37-12P	14.76	(375)
E6-80-12	E6-800-12-12	E6-800-12-12P	4.92	(125)	E6-80-38	E6-800-38-12	E6-800-38-12P	15.24	(387)
E6-80-13	E6-800-13-12	E6-800-13-12P	5.39	(137)	E6-80-40	E6-800-40-12	E6-800-40-12P	15.75	(400)
E6-80-15	E6-800-15-12	E6-800-15-12P	5.91	(150)	E6-80-41	E6-800-41-12	E6-800-41-12P	16.72	(412)
E6-80-16	E6-800-16-12	E6-800-16-12P	6.38	(162)	E6-80-42	E6-800-42-12	E6-800-42-12P	16.73	(425)
E6-80-17	E6-800-17-12	E6-800-17-12P	6.89	(175)	E6-80-43	E6-800-43-12	E6-800-43-12P	17.20	(437)
E6-80-18	E6-800-18-12	E6-800-18-12P	7.36	(187)	E6-80-45	E6-800-45-12	E6-800-45-12P	17.72	(450)
E6-80-20	E6-800-20-12	E6-800-20-12P	7.87	(200)	E6-80-46	E6-800-46-12	E6-800-46-12P	18.19	(462)
E6-80-21	E6-800-21-12	E6-800-21-12P	8.35	(212)	E6-80-47	E6-800-47-12	E6-800-47-12P	18.70	(475)
E6-80-22	E6-800-22-12	E6-800-22-12P	8.86	(225)	E6-80-48	E6-800-48-12	E6-800-48-12P	19.17	(487)
E6-80-23	E6-800-23-12	E6-800-23-12P	9.33	(237)	E6-80-50	E6-800-50-12	E6-800-50-12P	19.69	(500)
E6-80-25	E6-800-25-12	E6-800-25-12P	9.84	(250)	E6-80-51	E6-800-51-12	E6-800-51-12P	20.16	(512)
E6-80-26	E6-800-26-12	E6-800-26-12P	10.31	(262)	E6-80-52	E6-800-52-12	E6-800-52-12P	20.67	(525)
E6-80-27	E6-800-27-12	E6-800-27-12P	10.83	(275)	E6-80-53	E6-800-53-12	E6-800-53-12P	21.14	(537)
E6-80-28	E6-800-28-12	E6-800-28-12P	11.30	(287)	E6-80-55	E6-800-55-12	E6-800-55-12P	21.65	(550)
E6-80-30	E6-800-30-12	E6-800-30-12P	11.81	(300)	E6-80-60	E6-800-60-12	E6-800-60-12P	25.59	(600)

PDF: igus.com/e-chain-pdfs
Product information: igus.com/e-chains

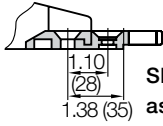
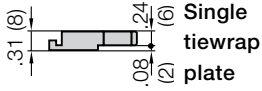

Tiewrap Plates

 Shown
 assembled

 Single
 tiewrap
 plate

Option 1:
Tiewrap plates as an individual part

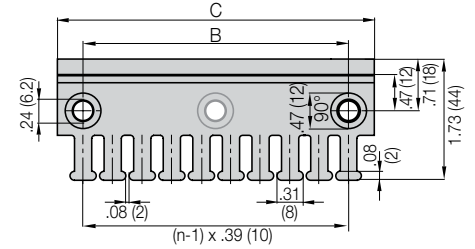
Available as an individual component, can be fixed onto a mounting bracket with the use of a profile rail.

Tiewrap Plate	n Number of Teeth	C Overall Width in. (mm)	B Bore Width in. (mm)	Center Bore
3050-ZB	5	1.97 (50)	1.18 (30)	no
3075-ZB	7	2.95 (75)	2.16 (55)	no
3100-ZB	10	3.94 (100)	3.15 (80)	no
3115-ZB	11	4.53 (115)	3.74 (95)	no
3125-ZB	12	4.92 (125)	4.13 (105)	no
3150-ZB	15	5.91 (150)	5.12 (130)	no
3175-ZB	17	6.89 (175)	6.10 (155)	no
3200-ZB	20	7.87 (200)	7.09 (180)	yes
3225-ZB	22	8.86 (225)	8.07 (205)	yes
3250-ZB	25	9.84 (250)	9.06 (230)	yes



If used with KMA brackets with profile rail please add "KMA" to the end of the part number.

Example: 3050-ZBKMA
Other strain relief elements
 ➤ **Strain Relief, Chapter 10**

PDF: igus.com/e-chain-pdfs
Product information: igus.com/e-chains



Price Index



Series E6-80L

Special Features / Options



Extremely low noise
Test results upon request



IPA Certificate: Class 1, according to standard DIN EN ISO 14644-1 for the E6 system
(Series E6-29-060-150-0-CR, (v = 1.64 ft/s, a = 3.28 ft/s²))



LEVEL 1 absorption confirmed by IPA-Fraunhofer-Institute according to SEMI E78-0998 for the E6 standard material

Assembly Tips

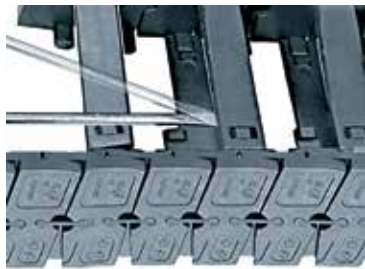

To close, push and click shut

Other Installation Methods

Vertical, hanging ≤ 196.8 ft (60 m)

Vertical, standing ≤ 13.12 ft (4 m)

Side-mounted, un_supp. =

possible to a limited extent

Unsupported length of upper run upon request

Usage Guidelines



- If a low-noise version is required
- For very high speeds and/or accelerations
- If large stresses and thrust forces are present
- For small bending radii
- If less vibration is required
- Minimal abrasion, suitable for cleanrooms



- For side mounted applications
 - Series 15050 E4/Light
- For RBR (Reverse Bending Radius)
 - Series 15050 E4/Light
- For high additional loads
 - Series 15050 E4/Light

Features & Benefits

- 1 KMA mounting brackets with attachment points on all sides
- 2 Increased inner height
- 3 Small pitch for low-noise, smooth operation
- 4 No pin and bore connection
- 5 Continuous glide surfaces
- 6 Available with or without integrated profile rail
- 7 Can be shortened or lengthened due to modular design
- 8 45% lighter in weight compared to the Series E6-80
- 9 Interior stop dog

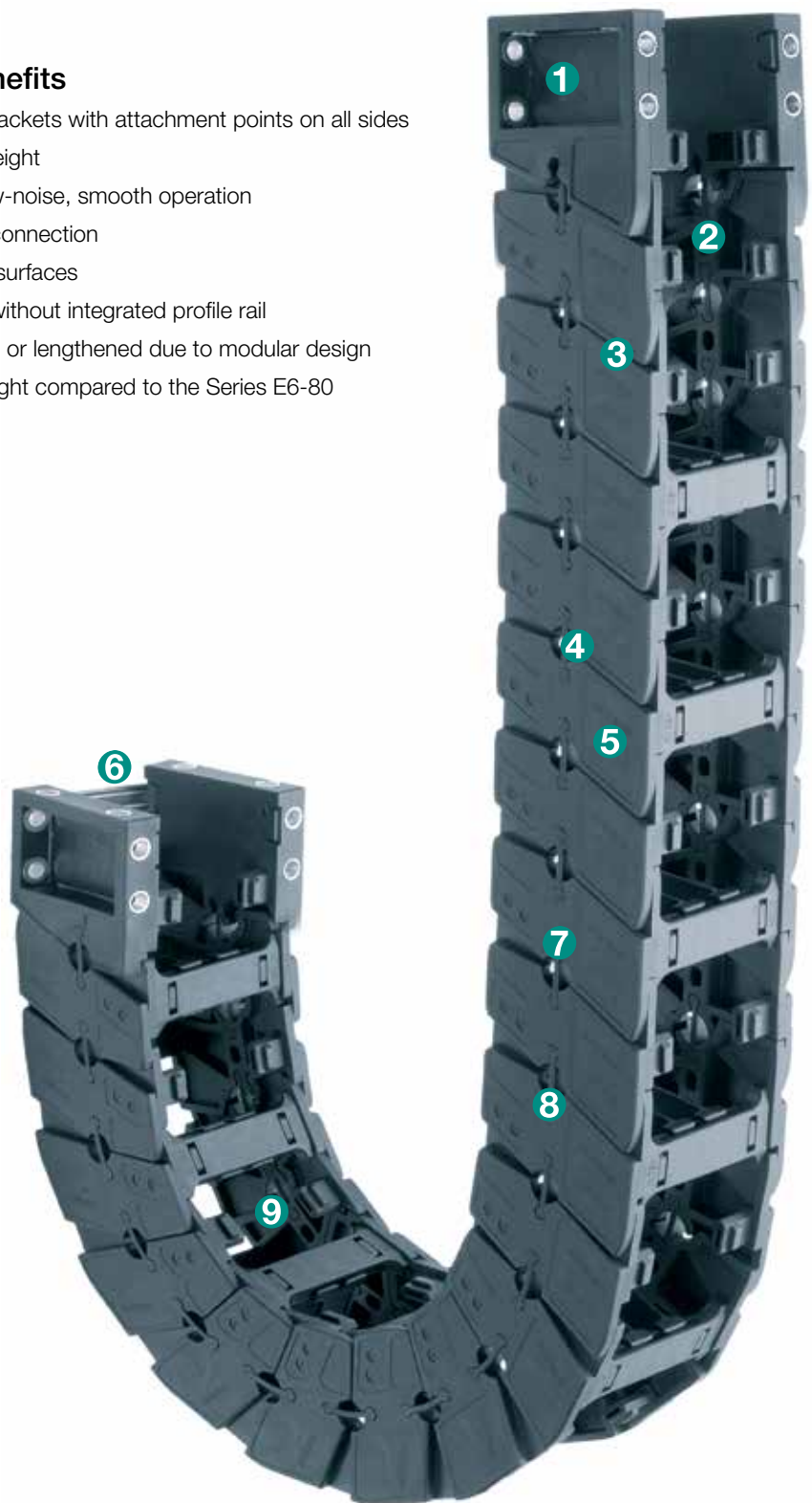

Order Example: Complete e-chain®

Please indicate chain length or number of links. Example:

16.4 ft (5 m) **E6-80L-15-175-0**

e-chain®

With 2 separators **511** assembled every 2nd link

Interior Separation

1 Set **E6-800L-15-12**

Mounting Bracket

e-chain system® E6

Series E6-80L

Installation Dimensions

Short travel, unsupported length

- FL_B = unsupported with permitted sag
- FL_G = unsupported with straight upper run

Further information ► Design, Chapter 1

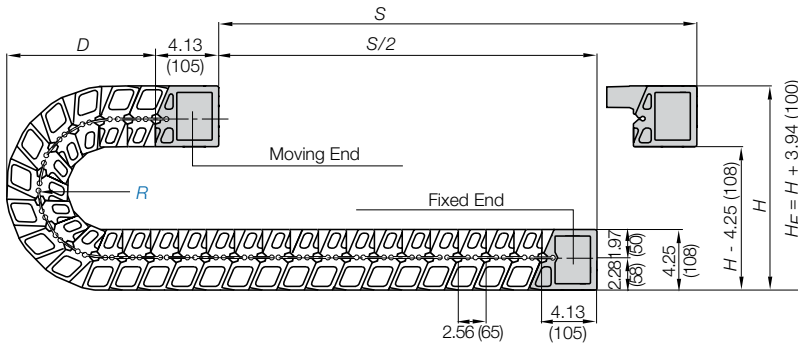
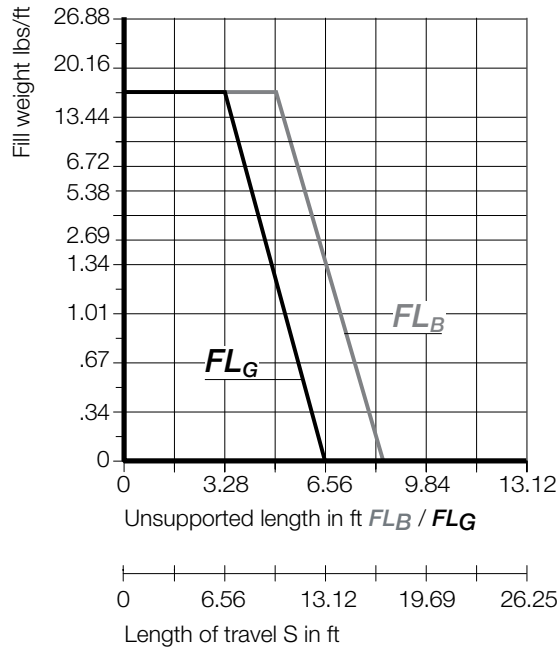
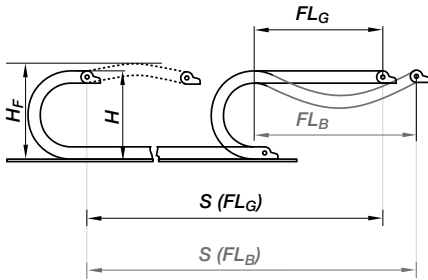

The required clearance height: $H_F = H + 3.94$ in. (100 mm) (with 3.36 lbs/ft (5.0 kg/m) fill weight. Please consult igus® if space is particularly restricted.

R	5.91 (150)	6.89 (175)	7.87 (200)	9.84 (250)	11.81 (300)
H*	20.31 (516)	22.28 (566)	24.25 (616)	28.19 (716)	32.13 (816)
D	12.05 (306)	13.03 (331)	14.02 (356)	15.98 (406)	17.95 (456)
K	23.82 (605)	26.77 (680)	29.92 (760)	36.02 (915)	42.32 (1075)

Pitch per link: = 2.56" (65 mm)

Links per ft (m): = 4.68 (16)

For center mount applications:

Chain length = $\frac{S}{2} + K$

Speed / acceleration FL_G	max. 65.6 ft/s (20 m/s) / max. 656 ft/s ² (200 m/s ²)
Speed / acceleration FL_B	max. 9.84 ft/s (3 m/s) / max. 19.69 ft/s ² (6 m/s ²)
Gliding speed / acceleration (maximum)	upon request
Permitted temperature	-40°F (-40°C) up to +158°F (+70° C)
Flammability Class	VDE 0304 IIC UL94 HB

igus®

E6-80L

Short Travels - Unsupported

3.15



Unsupported e-chains® feature positive camber over short travels. This must be accounted for when specifying the clearance height. Please refer to **Installation dimensions** for further details.

Legend

- S = Length of travel
- R = Bending radius
- H = Nominal clearance height
- D = Overlength e-chain® radius in final position
- $K = \pi \cdot R + \text{safety buffer}$
- H_F = Required clearance height

PDF: igus.com/e-chain-pdfs
Product information: igus.com/e-chains

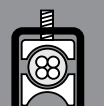

Technical Data



Details of material properties

► Design, Chapter 1

7.126

Series E6-80L - e-chain® with crossbars every other link

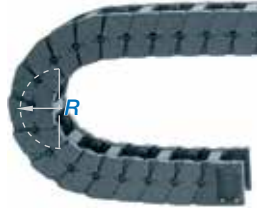
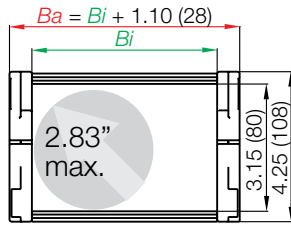

Part Number Structure

E6-80L-	15-	175-	0
---------	-----	------	---

- Color - Black
- Bending radius
- Width
- Series

e-chain® as separate parts, side links and crossbars

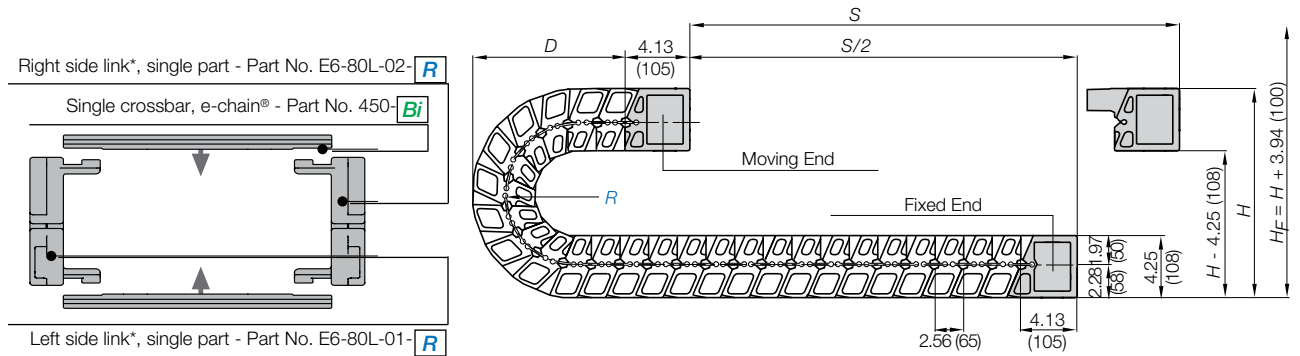

Polymer spring as single part -
Part No. E6-80-350

*View from the fixed point of the e-chain®/E-Tube

e-chain system® E6

Series E6-80L



E6-80L

Supplement part number with required radius. Example: E6-80L-15-175-0
Pitch: 2.56 in. (65 mm) per link links/ft (m) = 4.68 (16)

Part Number	<i>Bi</i>		<i>Ba</i>		Weight lbs/ft (kg/m)
	in. (mm)		in. (mm)		
E6-80L-08- <input type="checkbox"/> -0	3.43 (87)		4.53 (115)		≈ 2.20 (3.28)
E6-80L-10- <input type="checkbox"/> -0	3.94 (100)		5.04 (128)		≈ 2.24 (3.33)
E6-80L-11- <input type="checkbox"/> -0	4.41 (112)		5.51 (140)		≈ 2.26 (3.38)
E6-80L-12- <input type="checkbox"/> -0	4.92 (125)		6.02 (153)		≈ 2.30 (3.43)
E6-80L-13- <input type="checkbox"/> -0	5.39 (137)		6.50 (165)		≈ 2.35 (3.49)
E6-80L-15- <input type="checkbox"/> -0	5.91 (150)		7.01 (178)		≈ 2.39 (3.55)
E6-80L-16- <input type="checkbox"/> -0	6.38 (162)		7.48 (190)		≈ 2.43 (3.61)
E6-80L-17- <input type="checkbox"/> -0	6.89 (175)		7.99 (203)		≈ 2.47 (3.67)
E6-80L-18- <input type="checkbox"/> -0	7.36 (187)		8.46 (215)		≈ 2.51 (3.73)
E6-80L-20- <input type="checkbox"/> -0	7.87 (200)		8.98 (228)		≈ 2.55 (3.79)
E6-80L-21- <input type="checkbox"/> -0	8.35 (212)		9.45 (240)		≈ 2.59 (3.85)
E6-80L-22- <input type="checkbox"/> -0	8.86 (225)		9.96 (253)		≈ 2.63 (3.91)
E6-80L-23- <input type="checkbox"/> -0	9.33 (237)		10.43 (265)		≈ 2.67 (3.97)
E6-80L-25- <input type="checkbox"/> -0	9.84 (250)		10.94 (278)		≈ 2.70 (4.02)
E6-80L-26- <input type="checkbox"/> -0	10.31 (262)		11.42 (290)		≈ 2.75 (4.09)
E6-80L-27- <input type="checkbox"/> -0	10.83 (275)		11.93 (303)		≈ 2.78 (4.14)
E6-80L-28- <input type="checkbox"/> -0	11.30 (287)		12.40 (315)		≈ 2.82 (4.20)
E6-80L-30- <input type="checkbox"/> -0	11.81 (300)		12.91 (328)		≈ 2.86 (4.26)
E6-80L-31- <input type="checkbox"/> -0	12.28 (312)		13.39 (340)		≈ 2.90 (4.32)
E6-80L-32- <input type="checkbox"/> -0	12.80 (325)		13.90 (353)		≈ 2.94 (4.38)
E6-80L-33- <input type="checkbox"/> -0	13.27 (337)		14.37 (365)		≈ 2.98 (4.44)
E6-80L-35- <input type="checkbox"/> -0	13.78 (350)		14.88 (378)		≈ 3.02 (4.50)
E6-80L-36- <input type="checkbox"/> -0	14.25 (362)		15.35 (390)		≈ 3.06 (4.56)
E6-80L-37- <input type="checkbox"/> -0	14.76 (375)		15.87 (403)		≈ 3.10 (4.62)
E6-80L-38- <input type="checkbox"/> -0	15.24 (387)		16.34 (415)		≈ 3.14 (4.68)
E6-80L-40- <input type="checkbox"/> -0	15.75 (400)		16.85 (428)		≈ 3.19 (4.74)
E6-80L-41- <input type="checkbox"/> -0	16.22 (412)		17.32 (440)		≈ 3.23 (4.80)
E6-80L-42- <input type="checkbox"/> -0	16.73 (425)		17.83 (453)		≈ 3.26 (4.85)
E6-80L-43- <input type="checkbox"/> -0	17.20 (437)		18.31 (465)		≈ 3.31 (4.92)
E6-80L-45- <input type="checkbox"/> -0	17.72 (450)		18.82 (478)		≈ 3.38 (5.03)
E6-80L-46- <input type="checkbox"/> -0	18.19 (462)		19.29 (490)		≈ 3.42 (5.09)
E6-80L-47- <input type="checkbox"/> -0	18.70 (475)		19.80 (503)		≈ 3.46 (5.15)
E6-80L-48- <input type="checkbox"/> -0	19.17 (487)		20.28 (515)		≈ 3.50 (5.21)
E6-80L-50- <input type="checkbox"/> -0	19.69 (500)		20.79 (528)		≈ 3.54 (5.27)
E6-80L-51- <input type="checkbox"/> -0	20.16 (512)		21.26 (540)		≈ 3.58 (5.33)
E6-80L-52- <input type="checkbox"/> -0	20.67 (525)		21.77 (553)		≈ 3.62 (5.39)
E6-80L-53- <input type="checkbox"/> -0	21.14 (537)		22.24 (565)		≈ 3.66 (5.45)
E6-80L-55- <input type="checkbox"/> -0	21.65 (550)		22.76 (578)		≈ 3.70 (5.51)

Choose from the radii below for all of the above sizes
Radius (mm) Example: E6-80L-15-175-0

	150	175	200	250	300
R	5.91 (150)	6.89 (175)	7.87 (200)	9.84 (250)	11.81 (300)
H*	20.31 (516)	22.28 (566)	24.25 (616)	28.19 (716)	32.13 (816)
D	12.05 (306)	13.03 (331)	14.02 (356)	15.98 (406)	17.95 (456)
K	23.82 (605)	26.77 (680)	29.92 (760)	36.02 (915)	42.32 (1075)

PDF: igus.com/e-chain-pdfs
Product information: igus.com/e-chains



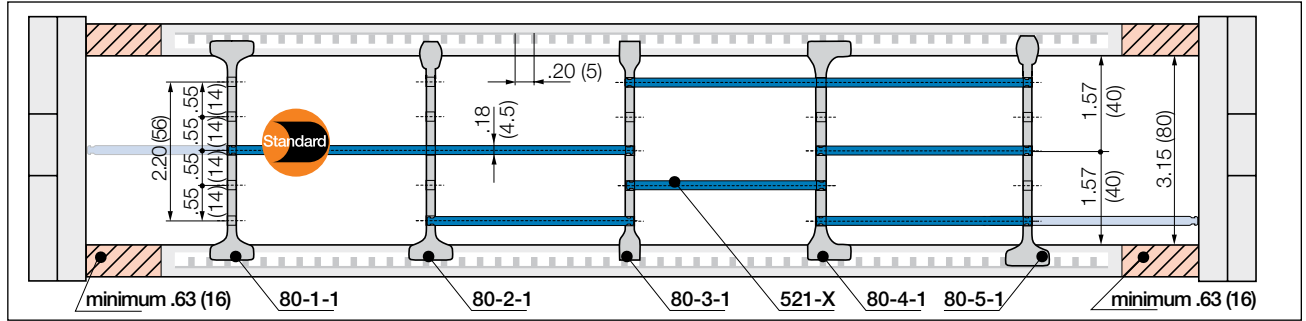

Note: Please maintain a lateral spacing of .63" (16 mm) between the separators and the side links.
In the standard configuration separators are assembled every 2nd e-chain® link

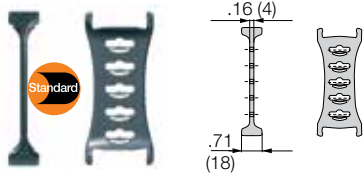

Separator, wide base

Unassembled	Part No. 80-1
Assembled	Part No. 80-1-1

- **Standard separator 80-1 for all applications**

Separator with wide base for maximum locking strength and safe standing in e-chains®.

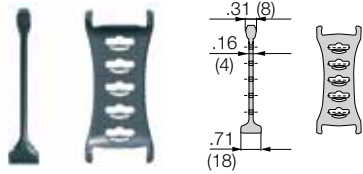

Separator for QuickLock crossbar

Unassembled	Part No. 80-2
Assembled	Part No. 80-2-1

- **Separator 80-2 For even faster installation**

Separator for QuickLock crossbar 385-X-Q. Firmly holds to one side with a wide base, narrow on opposite side for easy cable assembly (slight grip).

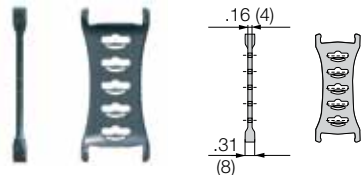

Separator, narrow base

Unassembled	Part No. 80-3
Assembled	Part No. 80-3-1

- **Separator 80-3 For many thin cables**

Separator with a narrow base for a large number of thin cables side by side. Save space in e-chains®.

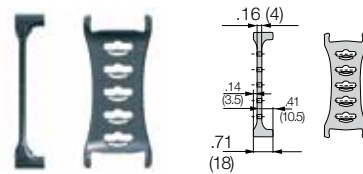

Separator, asymmetrical

Unassembled	Part No. 80-4
Assembled	Part No. 80-4-1

- **Separator 80-4 For side-mounted applications**

Asymmetrical separator, for defined distance. No additional spacers necessary.

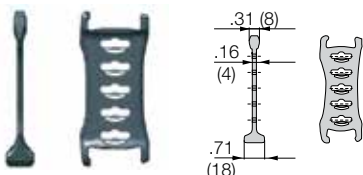

Notch separator for Notch crossbar

Unassembled	Part No. 80-5
Assembled	Part No. 80-5-1

- **Separator 80-5 Locks safely in .20" (5mm) increments**
Notch separator for exact positioning in e-chains®. Recommended for side mounted applications.

Lockable full-width shelves - for the standard interior separation

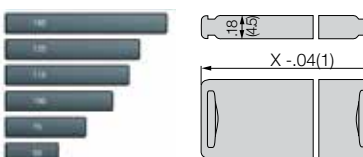

Full width shelf, lockable

Unassembled	Part No. 520-X
Assembled	Part No. 521-X

- **Full width shelf, lockable**
Shelf locks safely into separators on both ends, fixed width possible. Separators can be moved freely over the shelf horizontally. Can be arranged at three different heights.

Width X	Part No.	Part No.	Width X	Part No.	Part No.	Width X	Part No.	Part No.
in. (mm)	Unassembled	Assembled	in. (mm)	Unassembled	Assembled	in. (mm)	Unassembled	Assembled
1.97 (050)	520-050	521-050	5.91 (150)	520-150	521-150	11.81 (300)	520-300	521-300
2.55 (065)	520-065	521-065	6.89 (175)	520-175	521-175	13.78 (350)	520-350	521-350
2.95 (075)	520-075	521-075	7.87 (200)	520-200	521-200	14.76 (375)	520-375	521-375
3.94 (100)	520-100	521-100	8.86 (225)	520-225	521-225	15.24 (387)	520-387	521-387
4.92 (125)	520-125	521-125	9.84 (250)	520-250	521-250	17.72 (450)	520-450	521-450

e-chain system® E6
 Series E6-80L
 Interior Separation - Previous Generation



E6-80L



Option 1: Vertical separators and spacers

Vertical separators are used if a vertical subdivision of the e-chain® interior is required. By standard, vertical separators are assembled every other e-chain® link.

NOTE: Observe a lateral spacing of at least 1.30 in. (33mm) for E-Tubes and .63 in. (16mm) for e-chain®. There is no minimum spacing needed for side plates

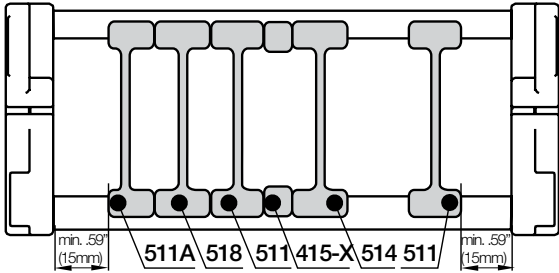

Vertical separator
501

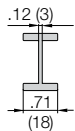

Vertical separator

Unassembled	Part No. 501
Assembled	Part No. 511

- **Standard separator 501**
 This separator offers safe stability due to its wide base design, also when used with thick cables or hoses.



Locking separator
504

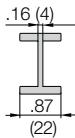

Locking separator

Unassembled	Part No. 504
Assembled	Part No. 514

- **Locking separator 504**
 This separator features increased retention force for applications exposed to very high humidity and extreme loads. If locking separators are used, the e-chain® is more difficult to open.



Locking separator
508

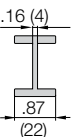

Locking separator

Unassembled	Part No. 508
Assembled	Part No. 518

- **Locking separator 508**
 This separator is used for applications that are exposed to extremely high humidity. The clamp at the side serves to uniformly align the separators. In order to avoid destroying the separators when opening the e-chain®, make sure all separators are identically aligned.



Asymmetric separator
501A

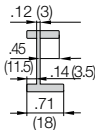

Asymmetrical separator

Unassembled	Part No. 501A
Assembled	Part No. 511A

- **Asymmetrical separator 501A**
 This separator features an (18mm) base. It can be used in combinations between spacers of different widths and vertical separators in side mounted applications.



Spacers
405-XX



Spacer

Unassembled	Part No. 405-XX
Assembled	Part No. 415-XX

XX = width of the spacer

- **NOTE ON SPACERS**
 Vertical separators are adjustable, but can be fixed in position by means of a spacer. Spacers are most often necessary for side mounted applications. The available inner height is reduced by .08" (2mm) **per spacer** (for example if one spacer is placed on either side of the separator, the overall inner height is reduced by .16" (4mm). To avoid this, place the spacers on the **outside** of the opening crossbar (**not for long travels**).

Spacers available in the following sizes:

Part No. Unassembled	Part No. Assembled	in.	(mm)
405 -10	415 -10	.39"	(10)
405 -15	415 -15	.59"	(15)
405 -20	415 -20	.79"	(20)
405 -30	415 -30	1.18"	(30)
405 -40	415 -40	1.57"	(40)



PDF: igus.com/e-chain-pdfs
 Product information: igus.com/e-chains





Option 2: Shelves

e-chains® and E-Tubes can be subdivided both vertically and horizontally using the various interior separation elements.

► **Design, Chapter 1** for layout recommendations.

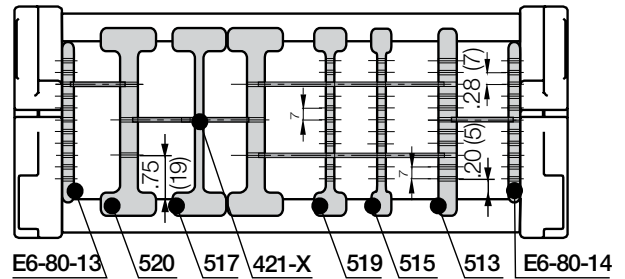

- **Side plates E6-80-03/E6-80-04**
This component is used to form the basic pattern of a shelf system.

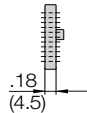

Side plate (left)

Unassembled **Part No. E6-80-03**

Assembled **Part No. E6-80-13**

Side plate (right)

Unassembled **Part No. E6-80-04**

Assembled **Part No. E6-80-14**

Side plate

E6-80-03 (left)

E6-80-04 (right)

- **Vertical separator 503**
This component is used to form the basic pattern of a shelf system.

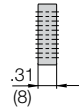

Vertical separator

Unassembled **Part No. 503**

Assembled **Part No. 513**

Vertical separator

503



- **Locking separator, slotted 507**
This separator features increased retention force for applications exposed to very high humidity and extreme loads. The extra retention force is achieved by asymmetric claws for the crossbar. Take care to ensure proper alignment.

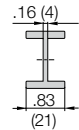

Locking separator, slotted

Unassembled **Part No. 507**

Assembled **Part No. 517**

Locking separator,
slotted

507



- **Locking vertical separator 510**
This separator is slotted and able to be combined with shelves.

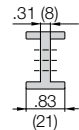

Locking vertical separator

Unassembled **Part No. 510**

Assembled **Part No. 520**

Locking vertical
separator

510



- **Slotted separators 505**
These are used for very complex subdivisions. However, they cannot be retrofitted into an existing separation system without removing the shelves first.

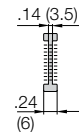

Slotted separators, closed

Unassembled **Part No. 505**

Assembled **Part No. 515**

Closed slotted
separator

505



- **Slotted separator 509**
This separator can be retrofitted into an existing interior separation system without removing the shelves, as long as these shelves fit into any of the 7 middle slots

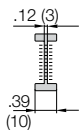

Slotted separators, open

Unassembled **Part No. 509**

Assembled **Part No. 519**

Open slotted
separator

509



Shelves 420-XX

These components form the basic pattern of a shelf system. Shelves of various widths can be arranged at 11 different heights in .28" (7mm) increments

Width X in.(mm)	Usable Width in.	Part No. Unassembled (mm)	Part No. Assembled	Width X in. (mm)	Usable Width in. (mm)	Part No. Unassembled	Part No. Assembled
.71 (18)	.39 (10)	420-18	421-18	2.95 (75)	2.64 (67)	420-75	421-75
.91 (23)	.59 (15)	420-23	421-23	3.46 (88)	3.15 (80)	420-88	421-88
.98 (25)	.67 (17)	420-25	421-25	3.94 (100)	3.62 (92)	420-100	421-100
1.10 (28)	.79 (20)	420-28	421-28	4.92 (125)	4.61 (117)	420-125	421-125
1.30 (33)	.98 (25)	420-33	421-33	5.91 (150)	5.59 (142)	420-150	421-150
1.69 (43)	1.38 (35)	420-43	421-43	6.89 (175)	6.57 (167)	420-175	421-175
1.97 (50)	1.65 (42)	420-50	421-50	7.36 (187)	7.05 (179)	420-187	421-187
2.44 (62)	2.13 (54)	420-62	421-62	7.87 (200)	7.56 (192)	420-200	421-200

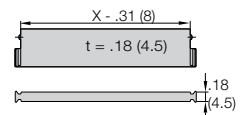

e-chain system® E6

Series E6-80L

Mounting Brackets - KMA



E6-80L



Option 1: KMA - Pivoting

- Option - profile rail with integrated strain relief chainfix clip or tiwrap plates
- Profile rail can be mounted in the inner or outer radius of the e-chain®
- Bolted connection outside of the chain cross-section
- Recommended for unsupported applications
- Confined installation conditions
- Attachment capability on all sides

Moving end
E6-800...2

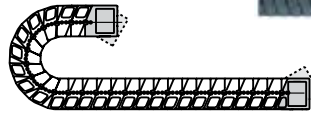

Fixed end
E6-800...1

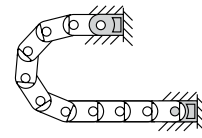

Possible installation configurations -

Part Number Structure

E6-800L-	10-	12	P
----------	-----	----	---

With profile rail

Complete Set

Width

Mounting brackets for selected chain type

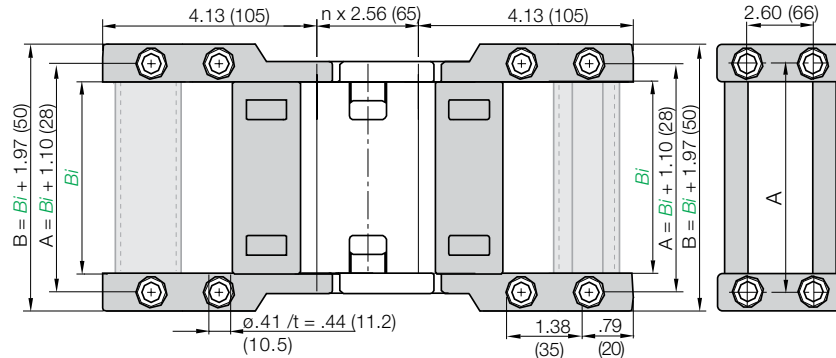

Full set, for both ends:

E6-800L-10-12 Full set,
both fixed and moving end

Single-part order:

E6-800L-10-1

Mounting bracket **fixed end**

E6-800L-10-2

Mounting bracket **moving end**

For Series	Part No. Full Set W/O Profile Rail	Part No. Full Set With Profile Rail	Bi in. (mm)	For Series	Part No. Full Set W/O Profile Rail	Part No. Full Set With Profile Rail	Bi in. (mm)
E6-80L-08	E6-800L-08-12	E6-800L-08-12P	3.43 (87)	E6-80L-32	E6-800L-32-12	E6-800L-32-12P	12.80 (325)
E6-80L-10	E6-800L-10-12	E6-800L-10-12P	3.94 (100)	E6-80L-33	E6-800L-33-12	E6-800L-33-12P	13.27 (337)
E6-80L-11	E6-800L-11-12	E6-800L-11-12P	4.41 (112)	E6-80L-35	E6-800L-35-12	E6-800L-35-12P	13.78 (350)
E6-80L-12	E6-800L-12-12	E6-800L-12-12P	4.92 (125)	E6-80L-36	E6-800L-36-12	E6-800L-36-12P	14.25 (362)
E6-80L-13	E6-800L-13-12	E6-800L-13-12P	5.39 (137)	E6-80L-37	E6-800L-37-12	E6-800L-37-12P	14.76 (375)
E6-80L-15	E6-800L-15-12	E6-800L-15-12P	5.91 (150)	E6-80L-38	E6-800L-38-12	E6-800L-38-12P	15.24 (387)
E6-80L-16	E6-800L-16-12	E6-800L-16-12P	6.38 (162)	E6-80L-40	E6-800L-40-12	E6-800L-40-12P	15.75 (400)
E6-80L-17	E6-800L-18-12	E6-800L-18-12P	6.89 (175)	E6-80L-41	E6-800L-41-12	E6-800L-41-12P	16.72 (412)
E6-80L-18	E6-800L-18-12	E6-800L-18-12P	7.36 (187)	E6-80L-42	E6-800L-42-12	E6-800L-42-12P	16.73 (425)
E6-80L-20	E6-800L-20-12	E6-800L-20-12P	7.87 (200)	E6-80L-43	E6-800L-43-12	E6-800L-43-12P	17.20 (437)
E6-80L-21	E6-800L-21-12	E6-800L-21-12P	8.35 (212)	E6-80L-45	E6-800L-45-12	E6-800L-45-12P	17.72 (450)
E6-80L-22	E6-800L-23-12	E6-800L-23-12P	8.86 (225)	E6-80L-46	E6-800L-46-12	E6-800L-46-12P	18.19 (462)
E6-80L-23	E6-800L-23-12	E6-800L-23-12P	9.33 (237)	E6-80L-47	E6-800L-47-12	E6-800L-47-12P	18.70 (475)
E6-80L-25	E6-800L-25-12	E6-800L-25-12P	9.84 (250)	E6-80L-48	E6-800L-48-12	E6-800L-48-12P	19.17 (487)
E6-80L-26	E6-800L-26-12	E6-800L-26-12P	10.31 (262)	E6-80L-50	E6-800L-50-12	E6-800L-50-12P	19.69 (500)
E6-80L-27	E6-800L-28-12	E6-800L-28-12P	10.83 (275)	E6-80L-51	E6-800L-51-12	E6-800L-51-12P	20.16 (512)
E6-80L-28	E6-800L-29-12	E6-800L-29-12P	11.30 (287)	E6-80L-52	E6-800L-52-12	E6-800L-52-12P	20.67 (525)
E6-80L-30	E6-800L-30-12	E6-800L-30-12P	11.81 (300)	E6-80L-53	E6-800L-53-12	E6-800L-53-12P	21.14 (537)
E6-80L-31	E6-800L-31-12	E6-800L-31-12P	12.28 (312)	E6-80L-55	E6-800L-55-12	E6-800L-55-12P	21.65 (550)

PDF: igus.com/e-chain-pdfs
Product information: igus.com/e-chains

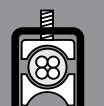

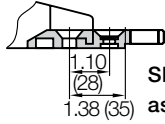
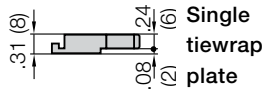
Tiewrap Plates

 Shown
 assembled

 Single
 tiewrap
 plate

Option 1:
Tiewrap plates as an individual part

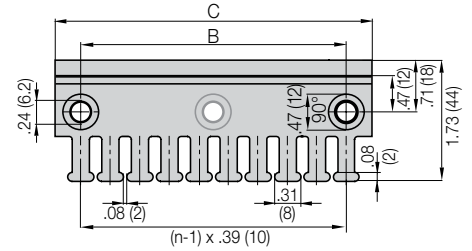
Available as an individual component, can be fixed onto a mounting bracket with the use of a profile rail.

Tiewrap Plate	n Number of Teeth	C Overall Width in. (mm)	B Bore Width in. (mm)	Center Bore
3050-ZB	5	1.97 (50)	1.18 (30)	no
3075-ZB	7	2.95 (75)	2.16 (55)	no
3100-ZB	10	3.94 (100)	3.15 (80)	no
3115-ZB	11	4.53 (115)	3.74 (95)	no
3125-ZB	12	4.92 (125)	4.13 (105)	no
3150-ZB	15	5.91 (150)	5.12 (130)	no
3175-ZB	17	6.89 (175)	6.10 (155)	no
3200-ZB	20	7.87 (200)	7.09 (180)	yes
3225-ZB	22	8.86 (225)	8.07 (205)	yes
3250-ZB	25	9.84 (250)	9.06 (230)	yes



If used with KMA brackets with profile rail please add "KMA" to the end of the part number.

Example: 3050-ZBKMA
Other strain relief elements

 ► **Strain Relief, Chapter 10**

PDF: igus.com/e-chain-pdfs
Product information: igus.com/e-chains







e-skin

Novel energy supply system for cleanrooms



- Hose consisting of an upper and lower shell that form a complete enclosure when connected together
- Easy filling with “zipper” function
- Special design allows unsupported lengths
- Less installation space required
- Cable-friendly with defined minimum bend radius
- Available with interior separation
- Prevents unintentional sideways movement
- Simple maintenance and inspection of the cables inside
- Protection against dust and water ingress
- Suitable for cleanrooms according to **IPA ISO class 1**



When to use another e-chain® series:

- For longer unsupported lengths
 - ▶ **E3**
 - ▶ **E6.1**
- For higher speeds
 - ▶ **E3,**
 - ▶ **E6.1**
- For high exposure to dirt
 - ▶ **RX e-tubes**



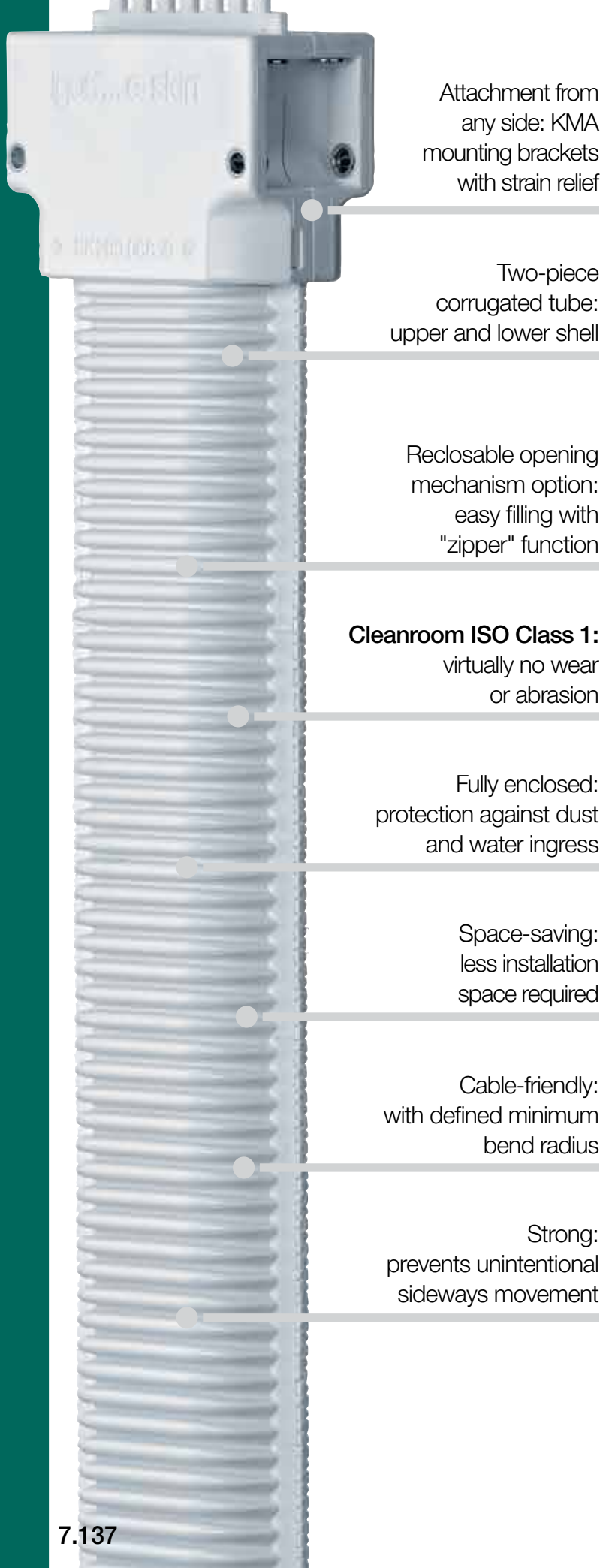

Attachment from any side: KMA mounting brackets with strain relief

Two-piece corrugated tube: upper and lower shell

Reclosable opening mechanism option: easy filling with "zipper" function

Cleanroom ISO Class 1: virtually no wear or abrasion

Fully enclosed: protection against dust and water ingress

Space-saving: less installation space required

Cable-friendly: with defined minimum bend radius

Strong: prevents unintentional sideways movement

Novel energy supply system for cleanrooms - e-skin®

e-skin® is a hose consisting of an upper and lower shell that form a complete enclosure when connected together. The simple and reclosable opening mechanism enables easy maintenance and inspection of the cables inside. e-skin® has many advantages over conventional corrugated tubes.

- Special design allows unsupported lengths
- Openable, quick assembly
- Available with interior separation
- Less installation space required
- Protection against dust and water ingress

Typical industries and applications

- Cleanroom ● Pick & Place ● Printers ● Any machine that uses corrugated hoses



Easy filling, can be opened and closed like a zipper



IPA Qualification Certificate2) - Report IG 1504-755:
 e-skin® **RBR** (prototype) tested at
 $v = 1.64 \text{ ft/s (0.5m/s)}, 3.28 \text{ ft/s (1m/s)}, 6.56 \text{ ft/s (2m/s)}$ and
 $a = 3.28 \text{ ft/s}^2 (1\text{m/s}^2), 6.56 \text{ ft/s}^2 (2\text{m/s}^2), 13.12 \text{ ft/s}^2 (4\text{m/s}^2)$

e-skin® - Selection table

Series	Inner height h_i in. (min)	Inner width B_i in. (min)	Outer width B_a in. (min)	Outer height h_a in. (min)	Bend radius $R_{min}^{1)}$ in. (min)
SK28	1.10 (28)	2.68 (68)	3.74 (95)	1.57 (40)	2.17 (055)
SK40	1.50 (38)	3.35 (85)	4.65 (118)	2.24 (57)	3.94 (100)



**e-skin® -
oval design**
Can be opened and closed like a zipper

¹⁾Note: The minimum bend radius is determined by the bottom of the e-skin® tube!



Available from stock. Orders ship as early as today.*

*On average 90% of orders ship the same day..



With the e-skin®, igus® offers a modular corrugated tube with a self-supporting function for energy supply in the smallest possible space. The product is certified in accordance with IPA ISO Class 1 and can be used in cleanrooms. e-skin® provides systems with data, media and energy without generating airborne particles through friction which could contaminate the room.

The corrugated tube is made up of abrasion-resistant plastic and its separable upper and lower shells can be easily put together by a "zipper" to a fully enclosed tube. This simultaneously guarantees cleanroom suitability as well as offering quick filling with cables.

e-chain system® e-skin® - Comparison e-skin® vs. conventional corrugated tubes

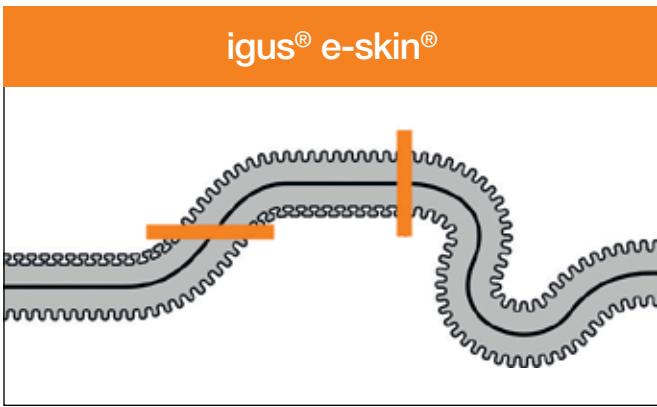

e-skin® consists of two shells (upper and lower). The shells can be configured in order to define movement

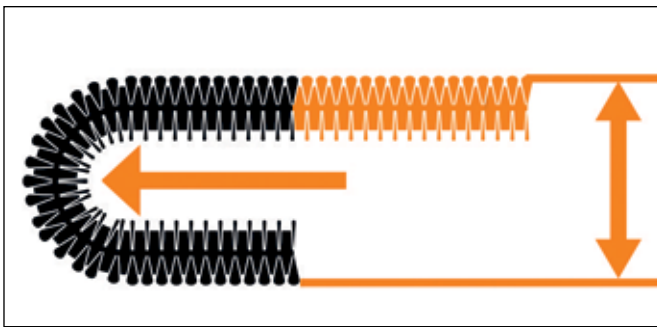

e-skin® is suitable for short unsupported lengths

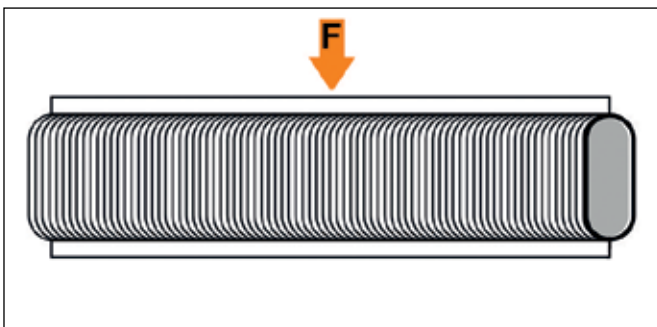

Lateral stability thanks to an oval geometry of the e-skin®

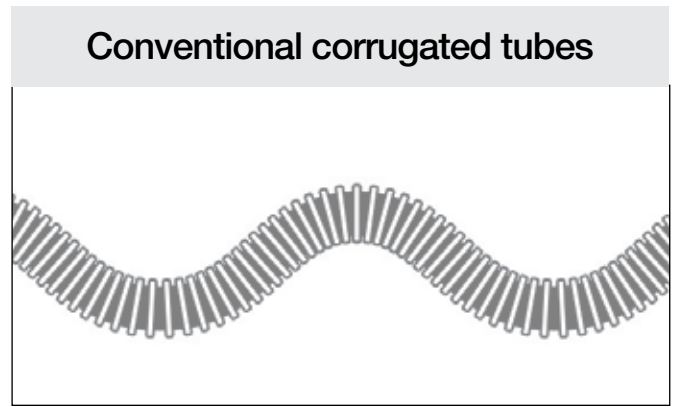

Corrugated tubes have the same bend radius along their entire length

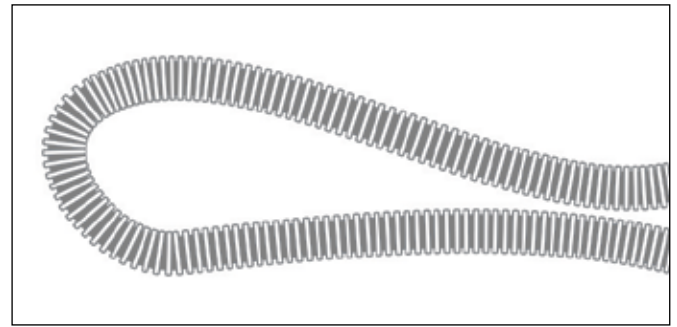

Corrugated tubes cannot be used for unsupported applications

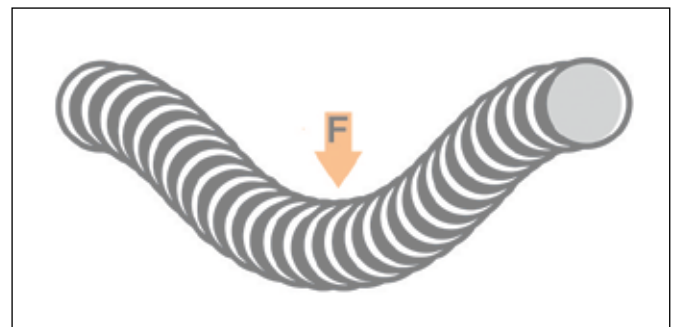

Very little, if any stability in respect of forces acting on the sides

e-chain system® e-skin® - Comparison e-skin® vs. conventional corrugated tubes

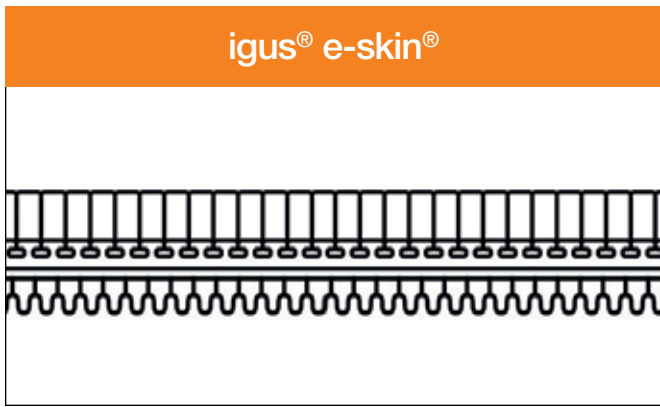

e-skin® supports itself

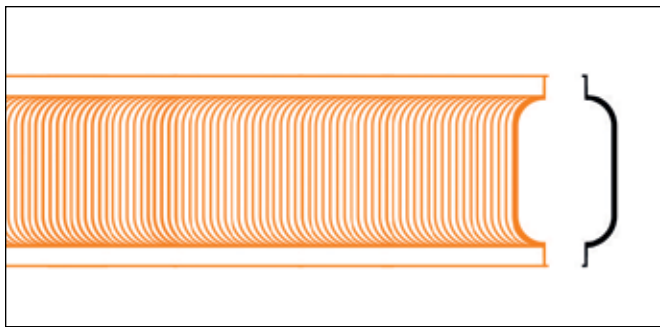

e-skin® is openable, easy to fill

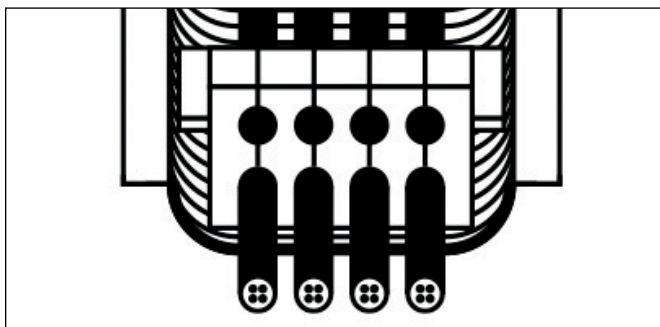

e-skin® can be fitted with interior separation

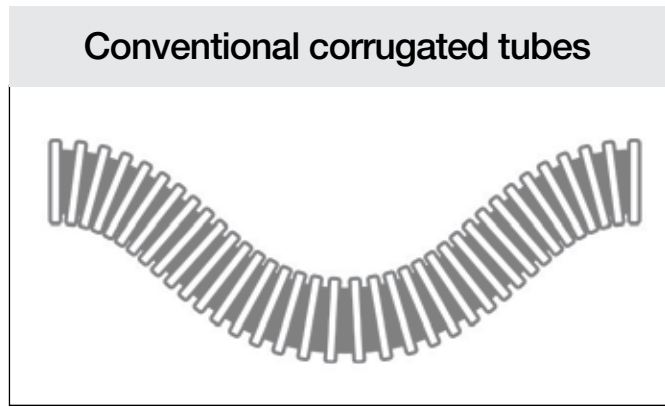

Corrugated tubes have very little any inherent rigidity. e-rib solves this ► **Chapter 2**

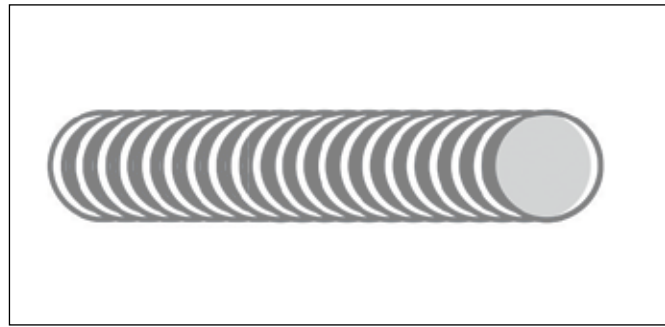

Corrugated tubes (for dynamic applications) cannot be opened

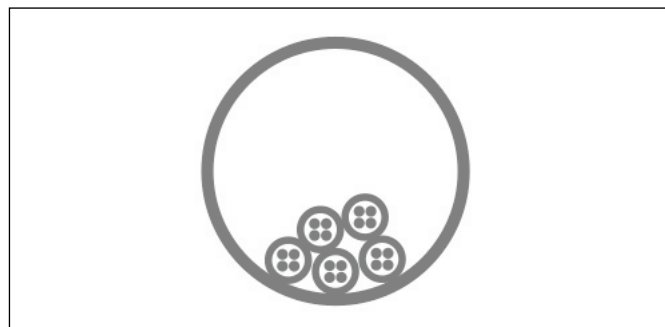

The interior of corrugated tubes cannot be divided into sections

Price Index

Series SK28

Special Options Available
Clean-room

Especially suitable for cleanroom environments

Assembly Tips

Option: Easy filling, can be opened and closed like a zipper

Other Installation Methods

Vertical, hanging - upon request

Vertical, standing - upon request

Side-mounted, un_supp. - upon request

Usage Guidelines



- When easy filling is required
- When less installation space required
- When protection against dust and water egress is necessary
- When cleanroom ISO Class 1 is required



- For longer unsupported lengths
 - Series E3
 - Series E6.1
- For higher speeds
 - Series E3
 - Series E6.1
- For high exposure to dirt
 - Series RX tubes

Features & Benefits

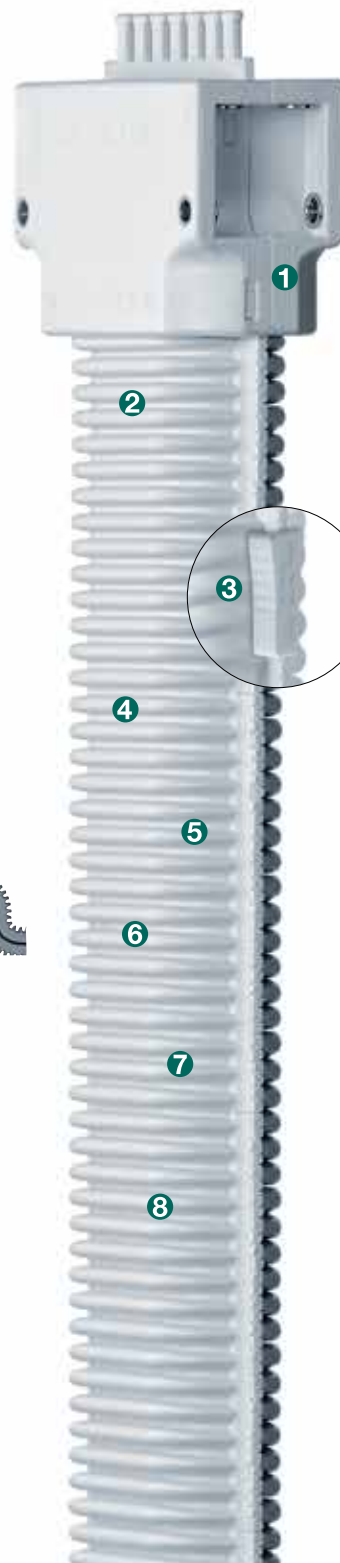
- 1 Attachment from any side: KMA mounting brackets with strain relief
- 2 Two-piece corrugated tube: upper and lower shell
- 3 Reclosable opening mechanism option: easy filling with zipper function
- 4 Cleanroom ISO Class 1: virtually no wear or abrasion
- 5 Fully enclosed: protection against dust and water egress
- 6 Space saving: less installation space required
- 7 Cable friendly: with defined minimum bend radius
- 8 Strong: prevents unintentional sideways movement
- 9 Also available with Reverse Bend Radius "RBR"

Order Example: Complete e-chain®

Please indicate chain length or number of links. Example:

3.28 ft (1000 mm) **SK28.068.02.1** (specify in mm)**e-chain®****SK28.1.1.01** fitted every 112 mm**Interior Separation**1 Set KMA with tiewrap plates **SK280.068.12.1****Mounting Bracket**

e-chain system® e-skin® Series SK28 Installation Dimensions

Short travel, unsupported length

● FL_G = unsupported with straight upper run

Further information ► Design, Chapter 1

igus®

SK28

1.10

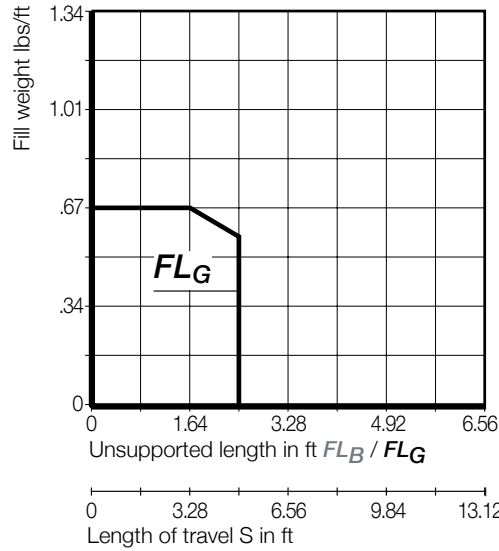

Short Travels - Unsupported

Unsupported e-chains® feature positive camber over short travels. This must be accounted for when specifying the clearance height. Please refer to **Installation dimensions** for further details.

Legend

- S = Length of travel
- R = Bending radius
- H = Nominal clearance height
- D = Overlength e-chain® radius in final position
- $K = \pi \cdot R + \text{safety buffer}$
- H_r = Required clearance height

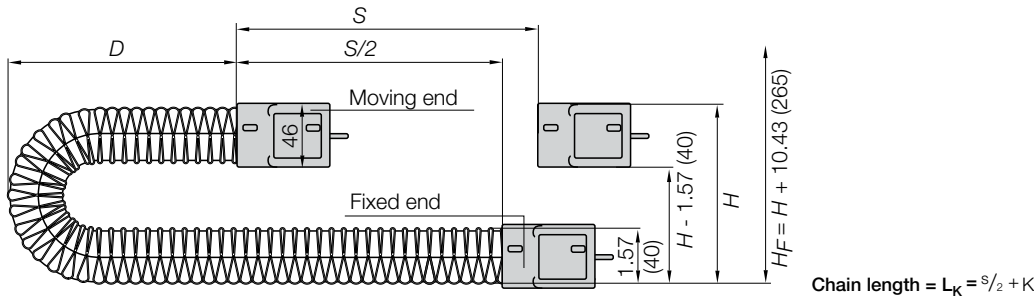

The required clearance height: $H_r = H + 10.43$ in. (265 mm) (with .50 lbs/ft (0.75 kg/m) fill weight). Please consult igus® if space is particularly restricted.

R_{min}^*	2.16 (055)	*NOTE: The minimum bend radius is determined by the bottom of the e-skin® tube!
H	9.84 (250)	No bend radius is specified in the part number since it depends on travel and fill weight. The smallest specified radius below is the minimum to guarantee the service life of the cables. In most applications,
D	6.30 (160)	however, the radius remains larger because the shape of the tube defines this.
K	15.71 (399)	

PDF: igus.com/e-chain-pdfs
Product information: igus.com/e-chains



Speed / acceleration FL_G	max. 32.8 ft/s (10 m/s) / max. 246 ft/s ² (75 m/s ²)
Speed / acceleration FL_B	upon request
Material, e-chain® - permitted temperature	igumid SK / +50°F (+10°C) up to +122°F (+50°C)
Material, mounting bracket - permitted temperature	igumid NB / +50°F (+10°C) up to +122°F (+50°C)
Flammability Class, igumid G	UL94 HB

Technical Data



Details of material properties
► Chapter 1

7.142

Series SK28 - Oval design - Can be opened and closed like a zipper

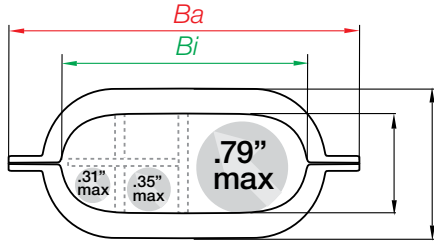

Part Number Structure

SK 28.068.02.1



Part No.	Bi	Ba	hi	ha	R bend radii	SK28
e-chain®	in. (mm)	in. (mm)	in. (mm)	in. (mm)	(mm)	lbs/ft (kg/m)
SK28.068.02.1	2.68 (68)	3.74 (95)	1.10 (28)	1.57 (40)	2.16 (055)	≈ 0.362 (0.54)

*Note: The minimum bend radius is determined by the bottom of the e-skin® tube!

Series SK28 - Interior Separation

e-skin separators should be fitted every 112mm onto the connection points!

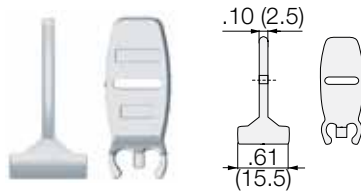

Separator, narrow head

Unassembled Part No. SK28.1.01

Assembled Part No. SK28.1.1.01

Vertical separator

The interior separation system for the igus® e-skin® consists of individual separators and full-width shelves, which can be fitted in a variety of ways.

Full-width shelves - for the standard interior separation

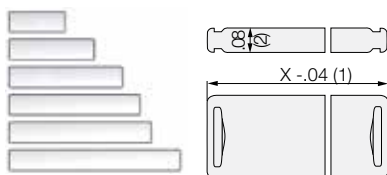

Full width shelf

Unassembled Part No. 110.63.1

Assembled Part No. 111.63.1

Full width shelf

is used in applications with many small cables with similar diameters.

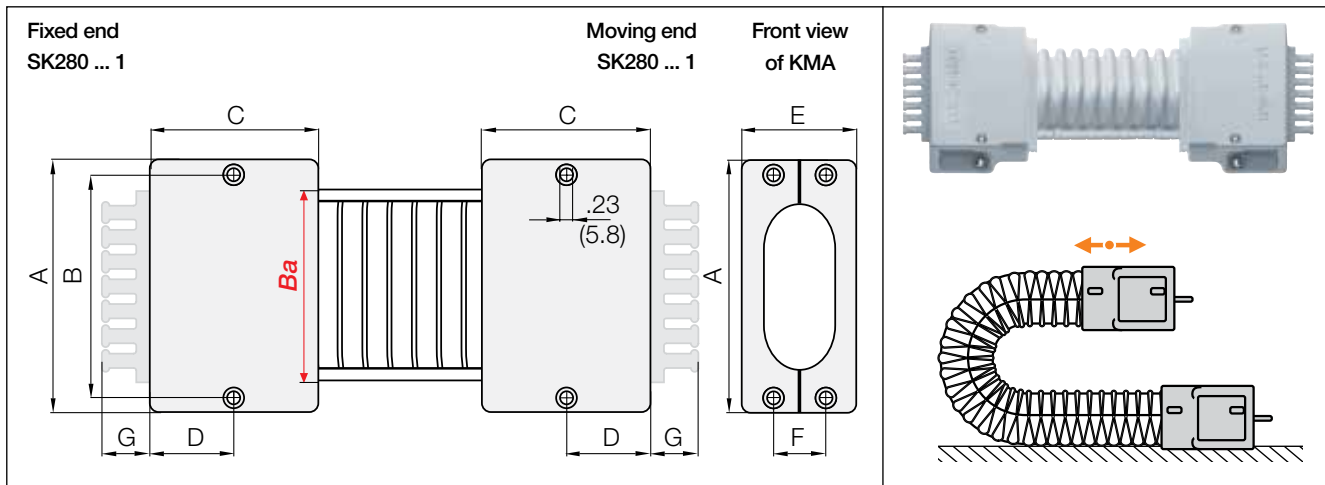

KMA | Recommended for unsupported, vertical hanging, standing applications

Width index	Part No. full set without tiewrap plates	Part No. full set with tiewrap plates	A in. (mm)	B in. (mm)	C in. (mm)	D in. (mm)	E in. (mm)	F in. (mm)	G in. (mm)	Number of teeth
068.	▶ SK280.068.12.1	SK280.068.12ZB.1	4.09 (104)	3.62 (92)	2.68 (68)	1.38 (35)	1.81 (46)	.83 (21)	.71(18)	7

(KMA = polymer metal mounting bracket)



Absolutely dust-free environment for printed-circuit-board production using the abrasion-resistant e-skin® from igus®

PDF: igus.com/e-chain-pdfs
 Product information: igus.com/e-chains



Price Index

Series SK40

Special Options Available
Clean-room

Especially suitable for cleanroom environments

Assembly Tips

Option: Easy filling, can be opened and closed like a zipper

Other Installation Methods

Vertical, hanging - upon request

Vertical, standing - upon request

Side-mounted, un_supp. - upon request

Usage Guidelines



- When easy filling is required
- When less installation space required
- When protection against dust and water egress is necessary
- When cleanroom ISO Class 1 is required



- For longer unsupported lengths
 - Series E3
 - Series E6.1
- For higher speeds
 - Series E3
 - Series E6.1
- For high exposure to dirt
 - Series RX tubes

Features & Benefits

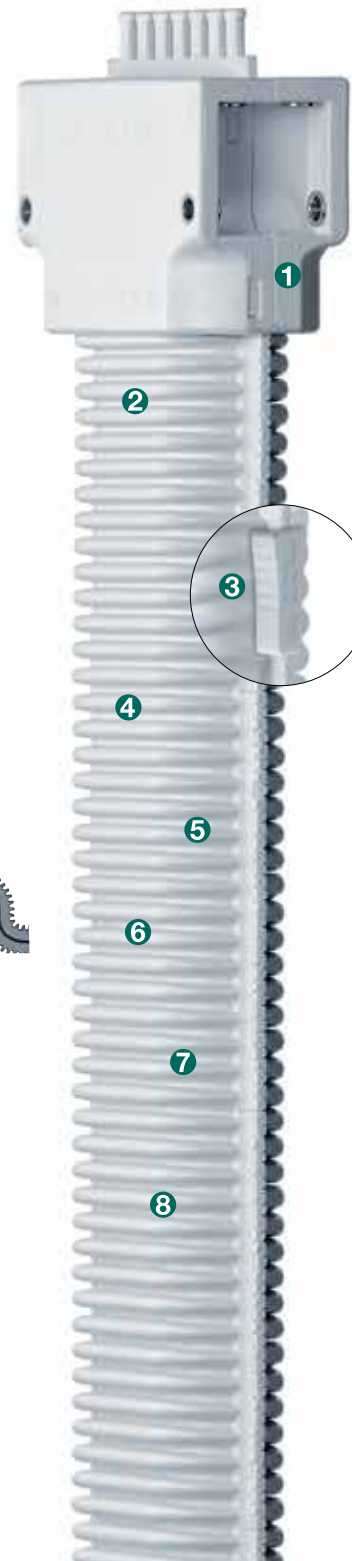
- 1 Attachment from any side: KMA mounting brackets with strain relief
- 2 Two-piece corrugated tube: upper and lower shell
- 3 Reclosable opening mechanism option: easy filling with zipper function
- 4 Cleanroom ISO Class 1: virtually no wear or abrasion
- 5 Fully enclosed: protection against dust and water egress
- 6 Space saving: less installation space required
- 7 Cable friendly: with defined minimum bend radius
- 8 Strong: prevents unintentional sideways movement
- 9 Also available with Reverse Bend Radius "RBR"

Order Example: Complete e-chain®

Please indicate chain length or number of links. Example:

3.28 ft (1000 mm) **SK40.085.02.1** (specify in mm)**e-chain®****SK40.1.1.01** fitted every 112 mm**Interior Separation**1 Set KMA with tiewrap plates **SK400.085.12.1****Mounting Bracket**

e-chain system® e-skin® Series SK40 Installation Dimensions

Short travel, unsupported length

● FL_G = unsupported with straight upper run

Further information ► Design, Chapter 1

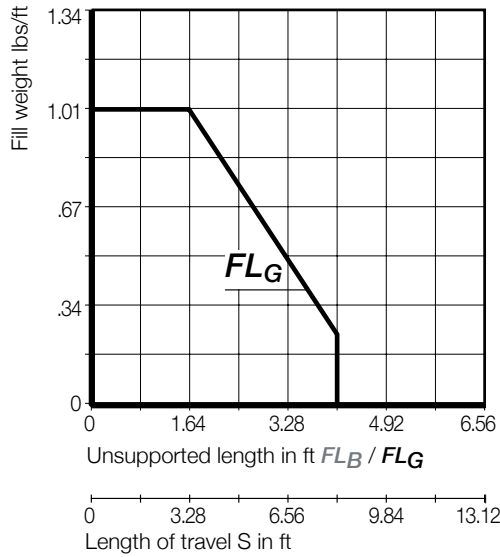

igus®

SK40

Short Travels -
Unsupported

1.50

Unsupported e-chains® feature positive camber over short travels. This must be accounted for when specifying the clearance height. Please refer to **Installation dimensions** for further details.

Legend

- S = Length of travel
- R = Bending radius
- H = Nominal clearance height
- D = Overlength e-chain® radius in final position
- $K = \pi \cdot R + \text{safety buffer}$
- H_r = Required clearance height

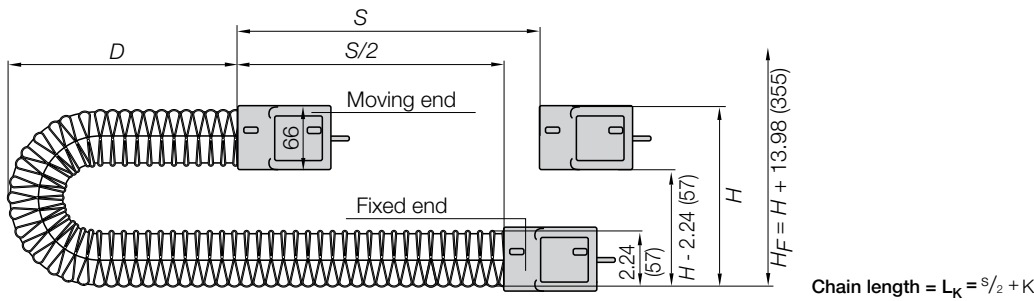

The required clearance height: $H_r = H + 13.98$ in. (355 mm) (with .50 lbs/ft (0.75 kg/m) fill weight. Please consult igus® if space is particularly restricted.

R_{min}^*	3.94 (100)	*NOTE: The minimum bend radius is determined by the bottom of the e-skin® tube! No bend radius is specified in the part number since it depends on travel and fill weight. The smallest specified radius below is the minimum to guarantee the service life of the cables. In most applications, however, the radius remains larger because the shape of the tube defines this.
H	13.78 (350)	
D	11.81 (300)	
K	27.28 (693)	

Speed / acceleration FL_G	max. 32.8 ft/s (10 m/s) / max. 246 ft/s ² (75 m/s ²)
Speed / acceleration FL_B	upon request
Material, e-chain® - permitted temperature	igumid SK / +50°F (+10°C) up to +122°F (+50°C)
Material, mounting bracket - permitted temperature	igumid NB / +50°F (+10°C) up to +122°F (+50°C)
Flammability Class, igumid G	UL94 HB

Technical Data



Details of material properties

► Chapter 1

PDF: igus.com/e-chain-pdfs
Product information: igus.com/e-chains



7.146

Series SK40 - Oval design - Can be opened and closed like a zipper

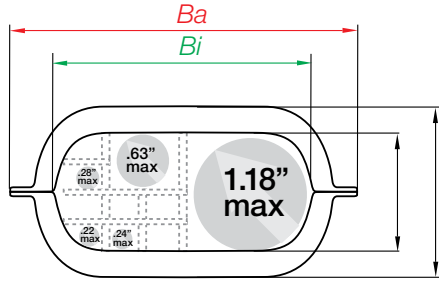

Part Number Structure

SK 40.085.02.1



Part No.	Bi	Ba	hi	ha	R bend radii	SK40
e-chain®	in. (mm)	in. (mm)	in. (mm)	in. (mm)	(mm)	lbs/ft (kg/m)
SK40.085.02.1	3.35 (85)	4.65 (118)	1.50 (38)	2.24 (57)	3.94 (100)	≈ 0.773 (1.15)

*Note: The minimum bend radius is determined by the bottom of the e-skin® tube!

Series SK40 - Interior Separation

e-skin separators should be fitted every 112mm onto the connection points!

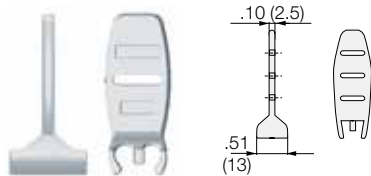

Separator, narrow head

Unassembled Part No. SK40.1.01

Assembled Part No. SK40.1.1.01

Vertical separator

The interior separation system for the igus® e-skin® consists of individual separators and full-width shelves, which can be fitted in a variety of ways.

Full-width shelves - for the standard interior separation

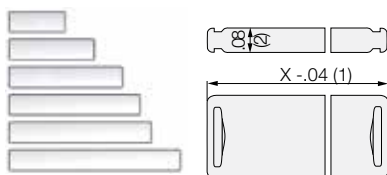

Full width shelf

Unassembled Part No. 110.80.1

Assembled Part No. 111.80.1

Full width shelf

is used in applications with many small cables with similar diameters.

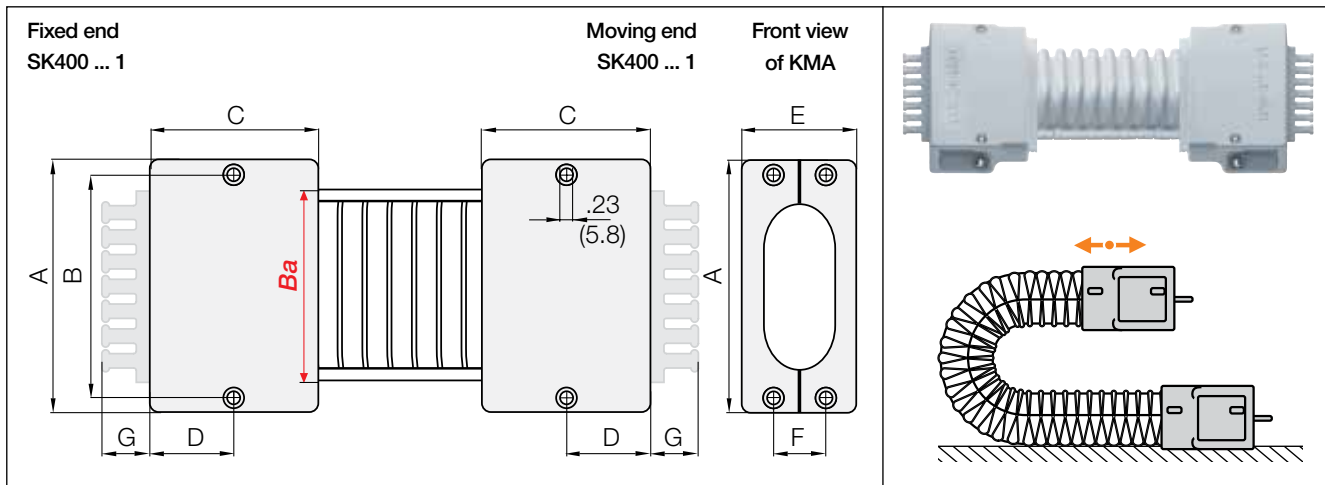

KMA | Recommended for unsupported, vertical hanging, standing applications

Width index	Part No. full set with tie-wrap plates	Part No. full set without tie-wrap plates	A in. (mm)	B in. (mm)	C in. (mm)	D in. (mm)	E in. (mm)	F in. (mm)	G in. (mm)	Number of teeth
085.	▶ SK400.085.12.1	SK400.085.12ZB.1	4.92 (125)	4.45 (113)	2.68 (68)	1.38 (35)	2.60 (66)	1.61 (41)	.71 (18)	10

(KMA = polymer metal mounting bracket)



The igus® e-skin® e-chain® can be used for short unsupported lengths in cleanrooms

PDF: igus.com/e-chain-pdfs
 Product information: igus.com/e-chains



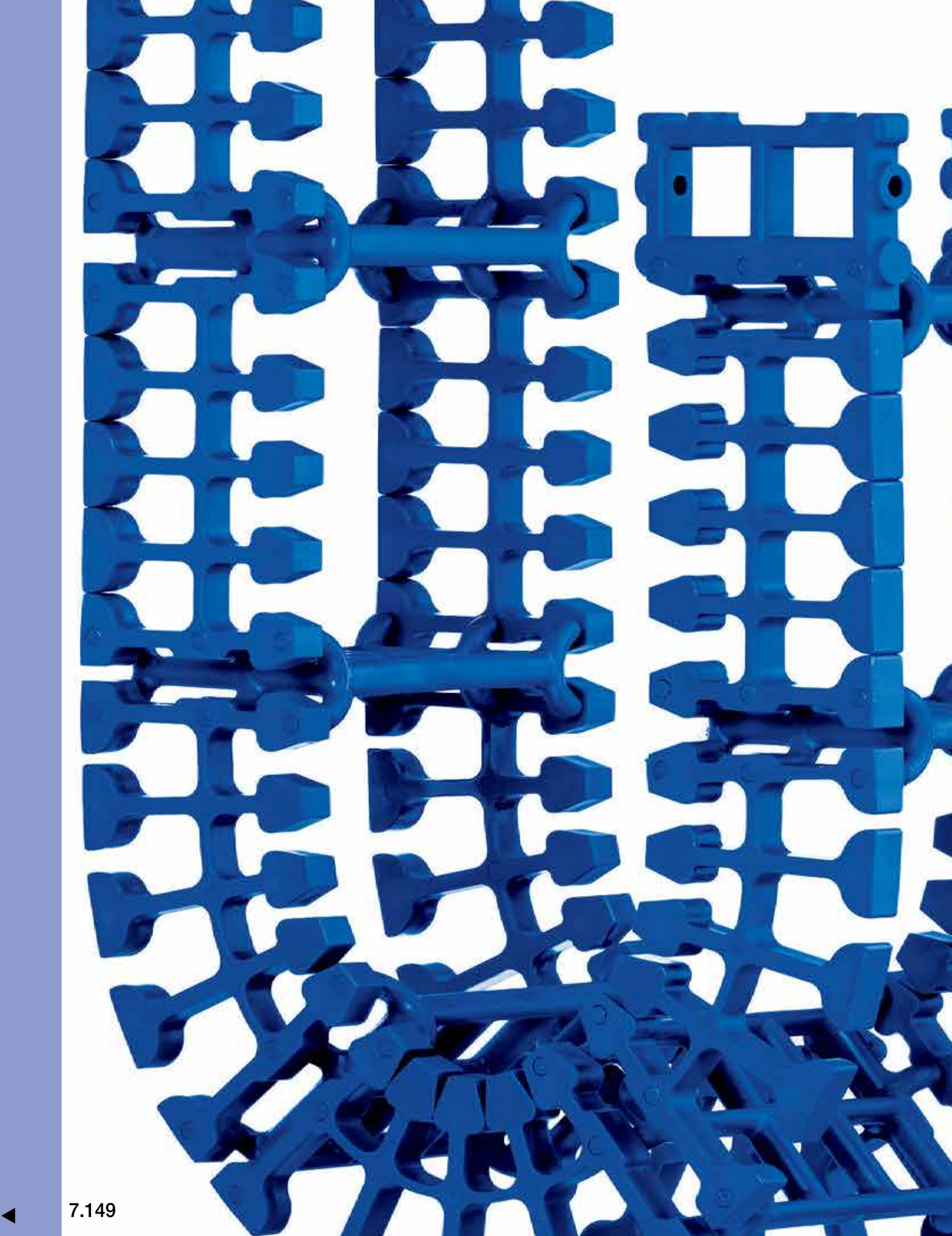



TH3

The first e-chain[®] designed according to hygienic principles



Advantages of the TH3 system:

- The first e-chain[®] designed according to hygienic principles
- Easy to clean due to open design
- FDA- and EU-compliant materials - blue material, typical for plastic parts in the food industry (consists of igumid TH NB for the side parts and igumid TH G for the frames and mounting brackets)
- Good resistance to aggressive cleaning agents and chemicals
- Rounded edges mean that there are no dead spaces or resulting germ formation
- No material on material rubbing
- No bolted connections
- Operating temperature -40°F / +158°F
- reddot award winner 2017



When to use another igus[®] e-chain[®] series:

- When hygienic design does not matter but cleanroom capability is required
 - ▶ T3
- When Cleanroom ISO Class 1 is required
 - ▶ E6.1

The first e-chain® designed according to hygienic principles - TH3

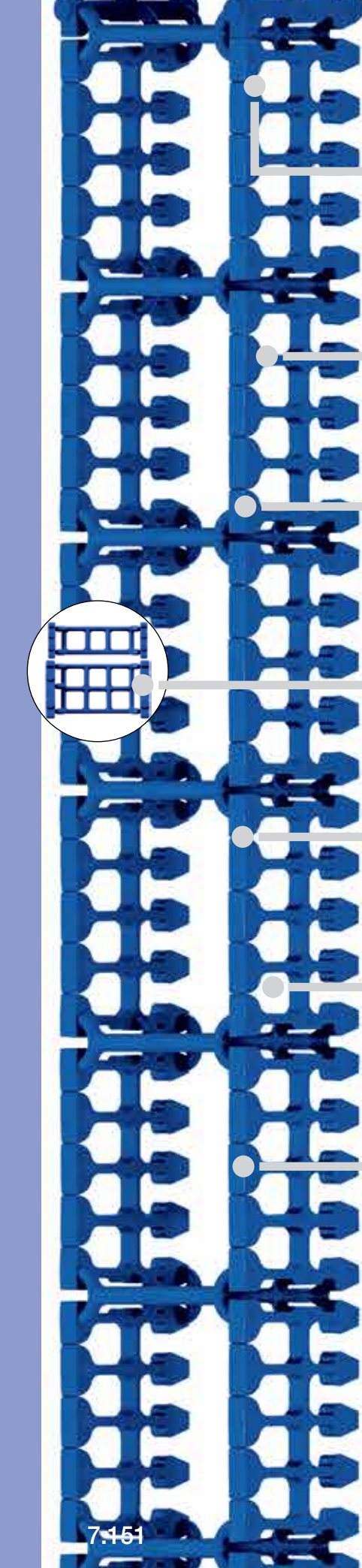

Attachment from any side:
polymer mounting
brackets

Easy to clean:
open design for effective
and easy cleaning

Hygienic design principle:
FDA-compliant materials

Modular design:
4 different widths for
interior separation,
available in 2 inner heights

Cable-friendly:
due to smooth,
rounded contours

No dead spaces:
large gaps - no
material overlaps

Food industry material:
resistant to detergents
and chemicals

The igus® TH3 e-chain® is the world's first plastic e-chain® developed according to "Hygienic Design Guidelines". The open design of the e-chain® is very easy to clean and, thanks to rounded corners and the absence of bolted connections, dead spaces and the resulting germ formation are avoided. The blue material, which is typical of plastic parts in the food industry, is also highly resistant to aggressive cleaning agents and chemicals. The e-chain® is suitable for applications with the highest hygienic requirements for safe cable and hose guidance.

- Choice of 2 inner heights and 4 inner widths
- Interior separation segments separate the cables and hoses from each other to provide enough clearance for easy cleaning
- For plastic parts in the food industry, the blue material is FDA-compliant
- reddot award winner 2017

Typical industries and applications

- Packaging machines
- Food and beverage/filling machines
- Wherever hygiene requirements are very high and cables and hoses have to be guided safely and securely



reddot award 2017
winner









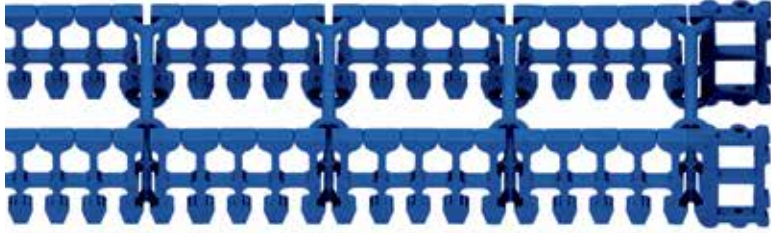

The material of the igus® hygienic design e-chain® is FDA and EU regulation-compliant

TH3 - Selection table

Segment design	Series	Inner height h_i in. (mm)	Inner width B_i in. (mm)	Outer width B_a in. (mm)	Outer height h_a in. (mm)	Bend radius R in. (mm)	Unsupported length \leq ft (m)
----------------	--------	--------------------------------	-------------------------------	-------------------------------	--------------------------------	-----------------------------	----------------------------------



**System TH3 -
hygienic design e-chain®**
3-piece, hygienic design
consisting of two side parts and an
interior separation segment

2-segment  	TH3.25.2/26	1.00 (25.5)	2.76 (70)	3.39 (86)	1.38 (35)	2.76 (070)	3.94 (1.2)
	TH3.45.2/20	2 x .79 (20)	2.76 (70)	3.54 (90)	2.24 (57)	3.54 (090)	4.59 (1.4)
3-segment  	TH3.25.3/26	1.00 (25.5)	3.74 (95)	4.37 (111)	1.38 (35)	2.76 (070)	3.94 (1.2)
	TH3.45.3/20	2 x .79 (20)	3.74 (95)	4.53 (115)	2.24 (57)	3.54 (090)	4.59 (1.4)
4-segment  	TH3.25.4/26*	1.00 (25.5)	4.72 (120)	5.35 (136)	1.38 (35)	2.76 (070)	3.94 (1.2)
	TH3.45.4/20*	2 x .79 (20)	4.72 (120)	5.51 (140)	2.24 (57)	3.54 (090)	4.59 (1.4)
5-segment  	TH3.25.5/26*	1.00 (25.5)	5.71 (145)	6.34 (161)	35 1.38 (35)	2.76 (070)	3.94 (1.2)
	TH3.45.5/20	2 x .79 (20)	5.71 (145)	6.50 (165)	2.24 (57)	3.54 (090)	4.59 (1.4)

*Width available upon request. Please consult igus® for delivery time.



Available from stock. Ready to ship in 24 - 48 hrs.*

*The delivery times indicated correspond to the average time until the ordered goods are dispatched.

Size overview - Interior separation segments

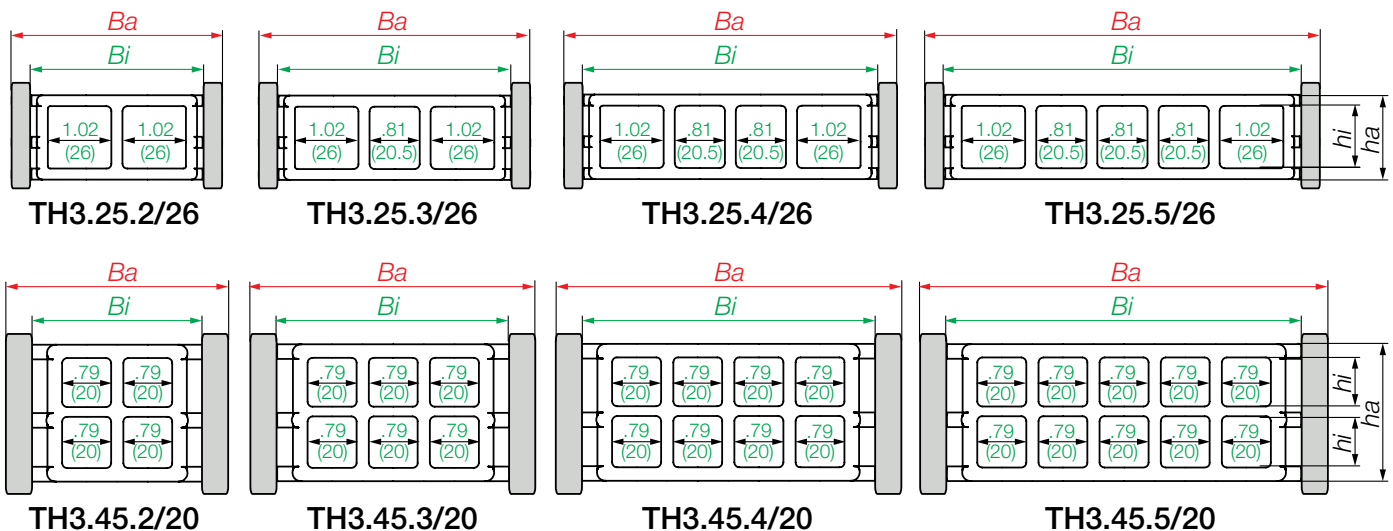

Price Index

Series TH3.25

Special Options Available

Especially suitable for clean-room environments

ESD classification:
Electrically conductive ESD
version upon request
Assembly Tips
Side segments of the e-chain[®] are connected using the interior separation segments
Other Installation Methods

Vertical, hanging ≤ 19.68 ft (6 m)

Vertical, standing ≤ 5.91 ft (1.8 m)

Usage Guidelines



- When an FDA/EU compliant material is required
- If an easy to clean open design is needed
- If good resistance to aggressive cleaning agents and chemicals is required



- When a hygienic design is not required
 - **Series T3**
- When cleanroom ISO Class 1 is required
 - **Series E6.1**

Features & Benefits

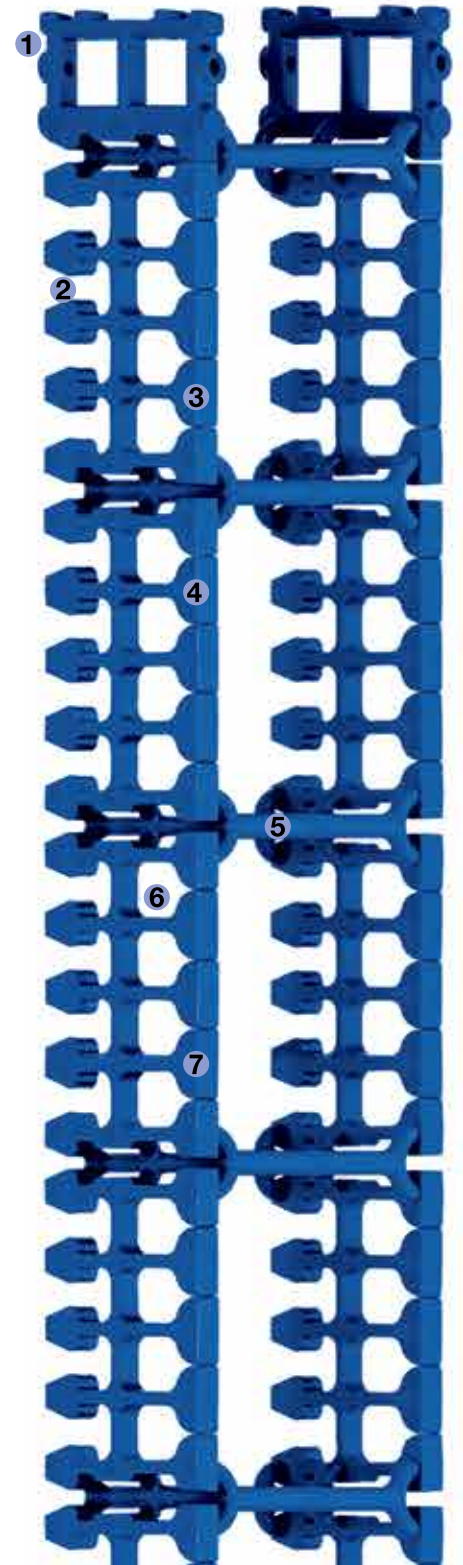
- 1 Attachment from any side: polymer mounting brackets
- 2 Easy to clean: open design for effective and easy cleaning
- 3 Hygienic design principle: FDA-compliant materials
- 4 Cable friendly due to smooth rounded contours
- 5 4 different widths for interior separation
- 6 No dead spaces. Large gaps - no material overlaps
- 7 Food industry material - resistant to detergents and chemicals

Order Example: Complete e-chain[®]

Please indicate chain length or number of links. Example:

3.28 ft (1 m) **TH3.25.3/26.070.8****e-chain[®]**The interior separation segments connect the side parts of the e-chain[®] and are included in the part number of the e-chain[®]**Interior Separation**1 Set **TH3.250.3/26.12.8****Mounting Bracket**

e-chain system® TH3

Series TH3.25

Installation Dimensions



TH3.25

Short travel, unsupported length

● FL_G = unsupported with straight upper run

Further information ► Design, Chapter 1

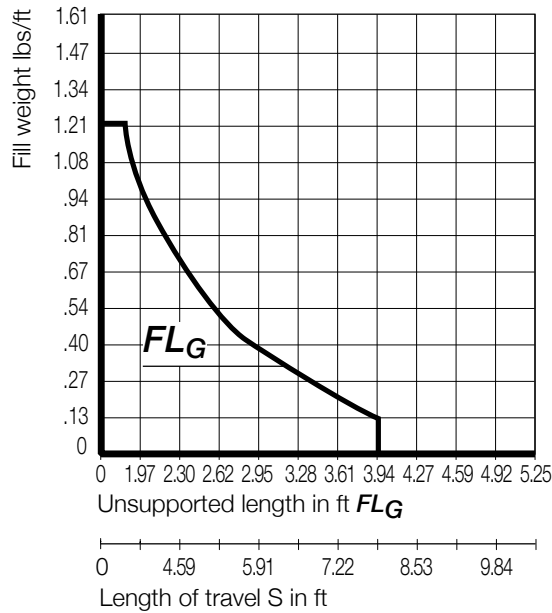

Short Travels - Unsupported

Unsupported e-chains® feature positive camber over short travels. This must be accounted for when specifying the clearance height. Please refer to **Installation dimensions** for further details.

Legend

- S = Length of travel
- R = Bending radius
- H = Nominal clearance height
- D = Overlength e-chain® radius in final position
- $K = \pi \cdot R + \text{safety buffer}$
- H_r = Required clearance height
- H_i = Trough inner height
- H_m = *Mounting height
- D = Overlength - long travels, gliding
- K_r = *Add-on

*If the mounting bracket location is set lower

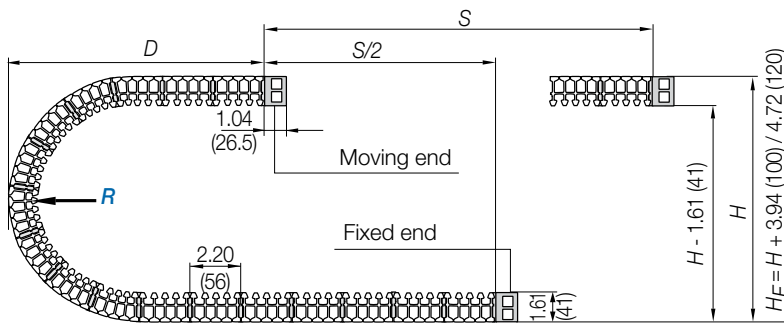

Pitch per link: = 2.20" (56 mm)

Links per ft (m) = 5.45 (18)

For center mount applications:

Chain length = $S/2 + K$

The required clearance height: $H_r = H + 3.94$ in. (100 mm) and accordingly $H = 4.72$ in. (120mm) (with .27 lbs/ft (0.4 kg/m) fill weight. Please consult igus® if space is particularly restricted.

R	2.76 (070)
H	7.09 (180)
D	4.33 (110)
K	9.45 (240)

TH3 - 3-piece hygienic design e-chain®

- The TH3 e-chain® consists of 3 parts, the two side parts ① and one interior separation segment ②
- The interior separation segments connect the side parts of the e-chain®
- The segments are available in 4 different widths

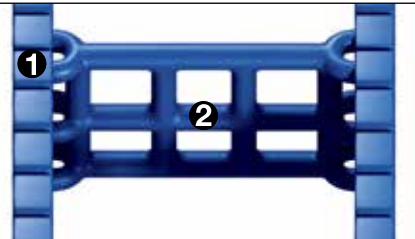

Speed / acceleration FL_G	upon request
Gliding speed / acceleration (maximum)	max. 32.8 ft/s (10 m/s) / max. 164 ft/s ² (50 m/s ²)
Material - side part	igumid TH NB / -40°F (-40°C) up to +158°F (+70 °C)
Material - Mounting bracket	igumid TH G / -40°F (-40°C) up to +158°F (+70 °C)
Material - interior separation segment	igumid TH G / -40°F (-40°C) up to +158°F (+70 °C)
Flammability Class, igumid TH NB	VDE 0304 IIC UL94 HB
Flammability Class, igumid TH G	VDE 0304 IIC UL94 HB

Technical Data



Details of material properties

► Chapter 1



PDF: igus.com/e-chain-pdfs
Product information: igus.com/e-chains



7.154

Series TH3.25 - Three-piece, hygienic design

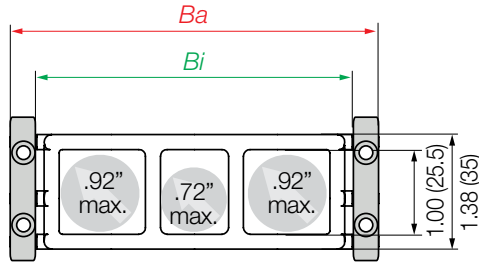

Part Number Structure

TH3. 25. 3/26. 070. 8

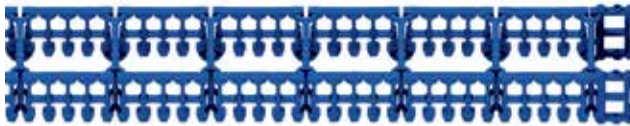

Segment design	Part No. e-chain®	Chamber width (mm)	Bi in. (mm)	Ba in. (mm)	R bend radii in. (mm)	TH3.25 lbs/ft (kg/m)
2-segment	TH3.25.2/26.R.8	26/26	2.76 (70)	3.39 (86)	2.76 (070)	≈ 0.302 (0.45)
3-segment	TH3.25.3/26.R.8	26/20.5/26	3.74 (95)	4.37 (111)	2.76 (070)	≈ 0.316 (0.47)
4-segment	TH3.25.4/26.R.8*	26/20.5/20.5/26	4.72 (120)	5.35 (136)	2.76 (070)	≈ 0.336 (0.50)
5-segment	TH3.25.5/26.R.8*	26/20.5/20.5/20.5/26	5.71 (145)	6.34 (161)	2.76 (070)	≈ 0.363 (0.54)

*Width available upon request. Please consult igus® for delivery time.

Complete Part No. with required radius (R). Example: TH3.25.3/26.070.8

Series TH3.25 - Interior separation segments - Size overview

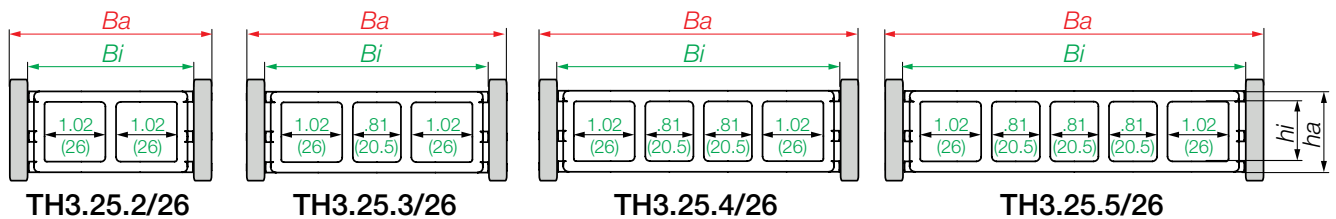

e-chain system® TH3
 Series TH3.25
 Interior Separation



TH3.25

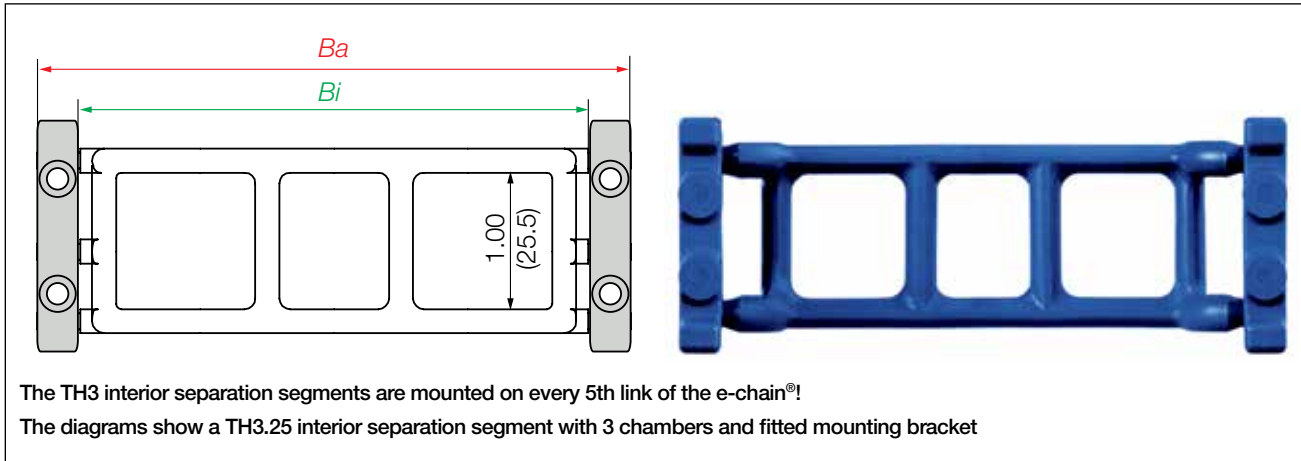

The TH3 interior separation segments are mounted on every 5th link of the e-chain®!
 The diagrams show a TH3.25 interior separation segment with 3 chambers and fitted mounting bracket

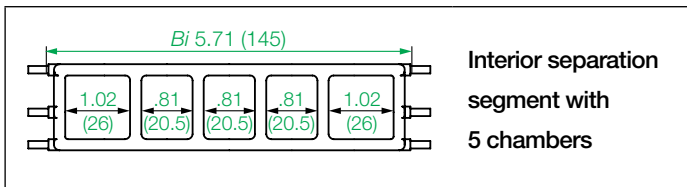
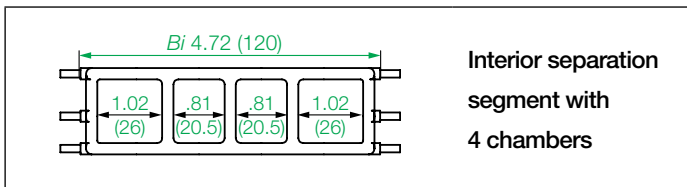
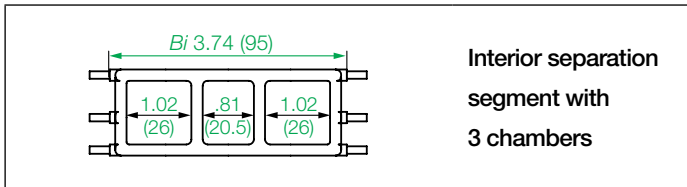
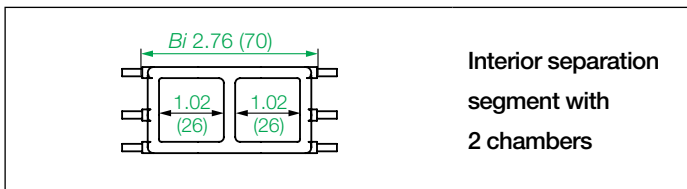

System TH3 - the open design allows effective and easy cleaning

PDF: igus.com/e-chain-pdfs
 Product information: igus.com/e-chains



FDA-compliant mounting brackets, locking - Attachment from any side

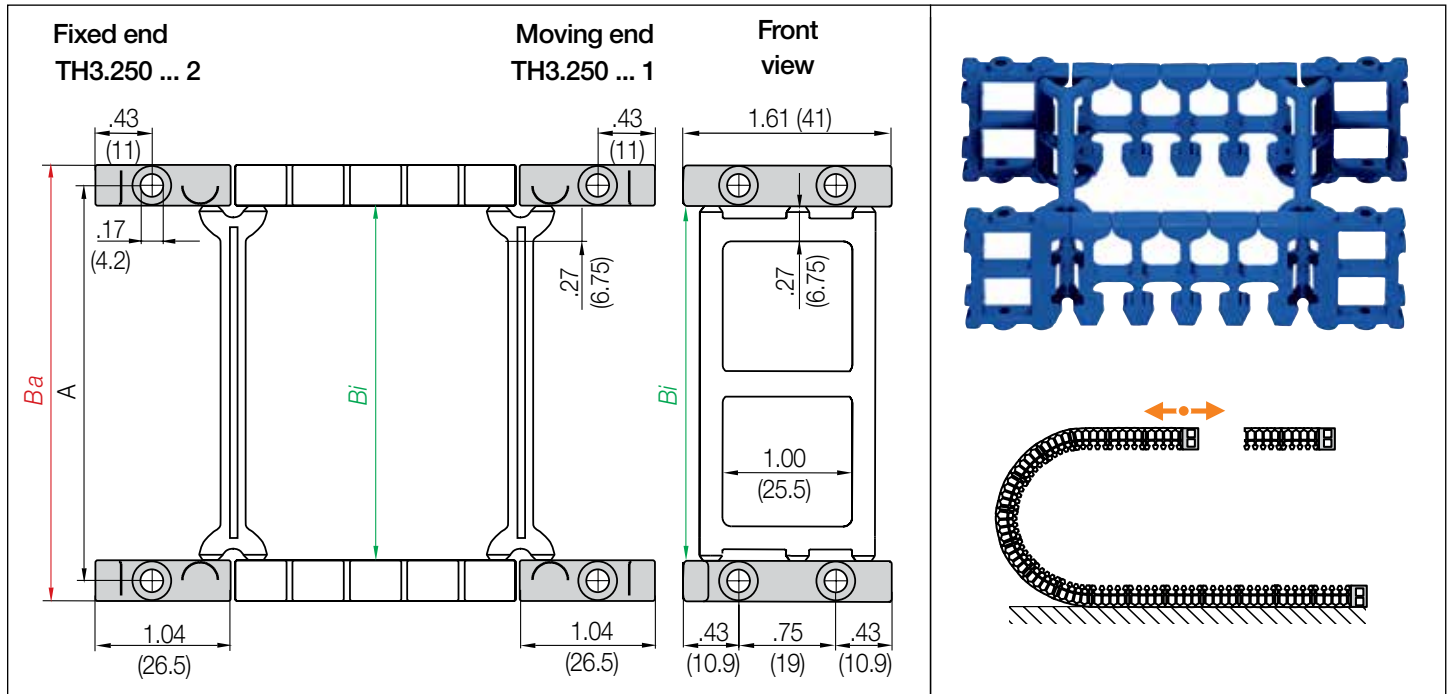

FDA-compliant mounting brackets, locking

Width index	Part No. full set locking	A in. (mm)	Bi in. (mm)	Ba in. (mm)
2/26 ▶	TH3.250.2/26.12.8	3.05 (77.5)	2.76 (70)	3.39 (86)
3/26 ▶	TH3.250.3/26.12.8	4.04 (102.5)	3.74 (95)	4.37 (111)
4/26 ▶	TH3.250.4/26.12.8*	5.02 (127.5)	4.72 (120)	5.35 (136)
5/26 ▶	TH3.250.5/26.12.8*	6.00 (152.5)	5.71 (145)	6.34 (161)

*Width available upon request. Please consult igus® for delivery time.



The TH3 e-chain® is the world's first plastic e-chain® developed according to "Hygienic Design Guidelines" (04/2018)

PDF: igus.com/e-chain-pdfs
Product information: igus.com/e-chains



Price Index

Series TH3.45

Special Options Available

Especially suitable for clean-room environments

ESD classification:
Electrically conductive ESD version upon request
Assembly Tips
Side segments of the e-chain[®] are connected using the interior separation segments
Other Installation Methods

Vertical, hanging ≤ 19.68 ft (6 m)

Vertical, standing ≤ 6.56 ft (2 m)

Usage Guidelines



- When an FDA/EU compliant material is required
- If an easy to clean open design is needed
- If good resistance to aggressive cleaning agents and chemicals is required



- When a hygienic design is not required
 - **Series T3**
- When cleanroom ISO Class 1 is required
 - **Series E6.1**

Features & Benefits

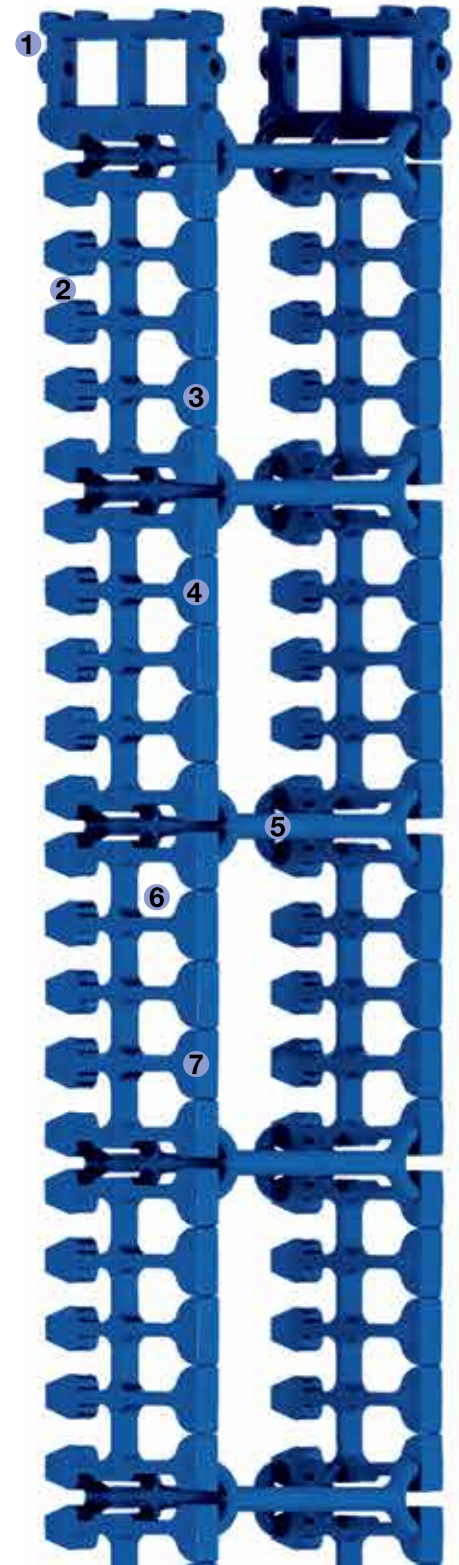
- 1 Attachment from any side: polymer mounting brackets
- 2 Easy to clean: open design for effective and easy cleaning
- 3 Hygienic design principle: FDA-compliant materials
- 4 Cable friendly due to smooth rounded contours
- 5 4 different widths for interior separation
- 6 No dead spaces. Large gaps - no material overlaps
- 7 Food industry material - resistant to detergents and chemicals

Order Example: Complete e-chain[®]

Please indicate chain length or number of links. Example:

3.28 ft (1 m) **TH3.45.3/20.090.8****e-chain[®]**The interior separation segments connect the side parts of the e-chain[®] and are included in the part number of the e-chain[®]**Interior Separation**1 Set **TH3.450.3/20.12.8****Mounting Bracket**

e-chain system® TH3

Series TH3.45

Installation Dimensions



TH3.45

Short travel, unsupported length

- FL_G = unsupported with straight upper run

Further information ► Design, Chapter 1

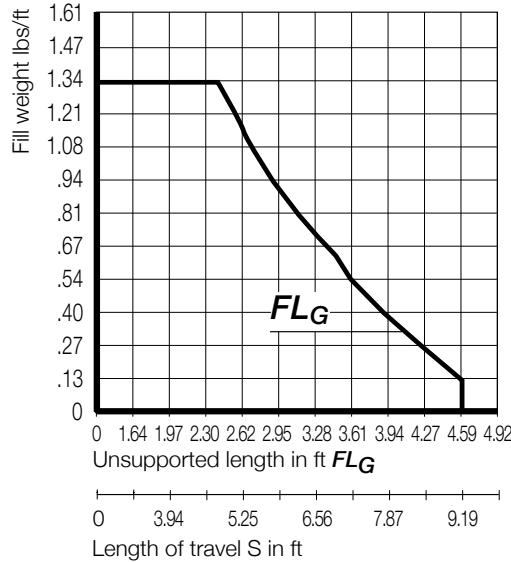

Short Travels - Unsupported

Unsupported e-chains® feature positive camber over short travels. This must be accounted for when specifying the clearance height. Please refer to **Installation dimensions** for further details.

Legend

- S = Length of travel
- R = Bending radius
- H = Nominal clearance height
- D = Overlength e-chain® radius in final position
- $K = \pi \cdot R + \text{safety buffer}$
- H_r = Required clearance height

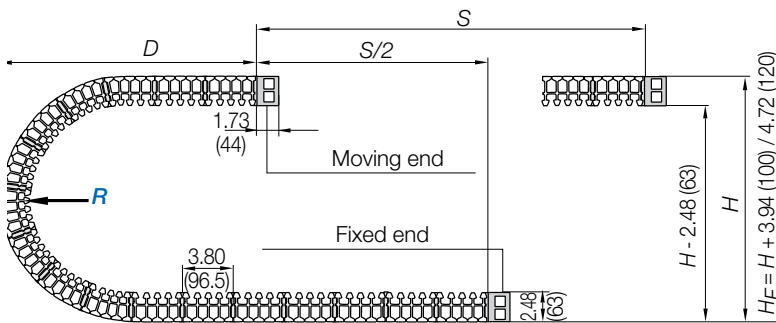

Pitch per link = 3.80" (96.5 mm)
 Links per ft (m) = 3.16 (11)
 For center mount applications:
 Chain length = $S/2 + K$

The required clearance height: $H_r = H + 3.94$ in. (100 mm) and accordingly $H = 4.72$ in. (120mm) (with .67 lbs/ft (1.0 kg/m) fill weight). Please consult igus® if space is particularly restricted.

R	3.54 (090)
H	9.84 (250)
D	4.72 (120)
K	13.31 (338)

TH3 - 3-piece hygienic design e-chain®

- The TH3 e-chain® consists of 3 parts, the two side parts ① and one interior separation segment ②
- The interior separation segments connect the side parts of the e-chain®
- The segments are available in 4 different widths

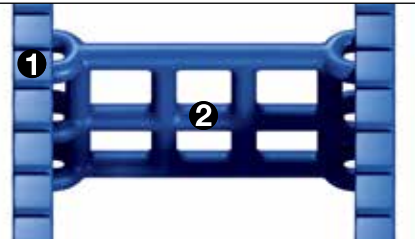

Speed / acceleration FL_G	upon request
Gliding speed / acceleration (maximum)	max. 32.8 ft/s (10 m/s) / max. 164 ft/s² (50 m/s²)
Material - side part	igumid TH NB / -40°F (-40°C) up to +158°F (+70°C)
Material - Mounting bracket	igumid TH G / -40°F (-40°C) up to +158°F (+70°C)
Material - interior separation segment	igumid TH G / -40°F (-40°C) up to +158°F (+70°C)
Flammability Class, igumid TH NB	VDE 0304 IIC UL94 HB
Flammability Class, igumid TH G	VDE 0304 IIC UL94 HB

Technical Data



Details of material properties

► Chapter 1

PDF: igus.com/e-chain-pdfs
 Product information: igus.com/e-chains



Series TH3.45 - Three-piece, hygienic design

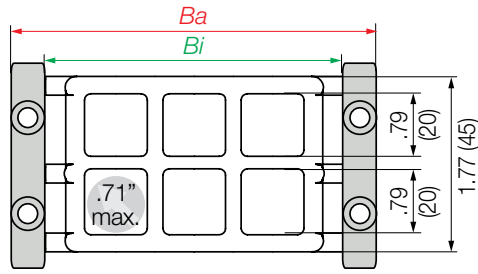

Part Number Structure

TH3. 45. **3/20**. **090**. **8**

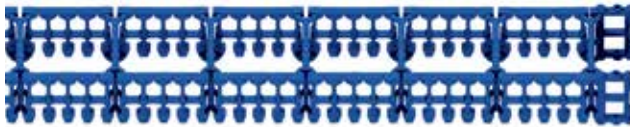

Segment design	Part No. e-chain®	Chamber width (mm)	Bi in. (mm)	Ba in. (mm)	R bend radii in. (mm)	TH3.45 lbs/ft (kg/m)
2-segment	TH3.45.2/20.R.8	20/20	2.76 (70)	3.54 (90)	3.54 (090)	≈ 0.551 (0.82)
3-segment	TH3.45.3/20.R.8	20/20/20	3.74 (95)	4.53 (115)	3.54 (090)	≈ 0.585 (0.87)
4-segment	TH3.45.4/20.R.8*	20/20/20/20	4.72 (120)	5.51 (140)	3.54 (090)	≈ 0.618 (0.92)
5-segment	TH3.45.5/20.R.8*	20/20/20/20/20	5.71 (145)	6.50 (165)	3.54 (090)	≈ 0.659 (0.98)

*Width available upon request. Please consult igus® for delivery time.

Complete Part No. with required radius (R). Example: TH3.45.3/20.090.8

Series TH3.45 - Interior separation segments - Size overview

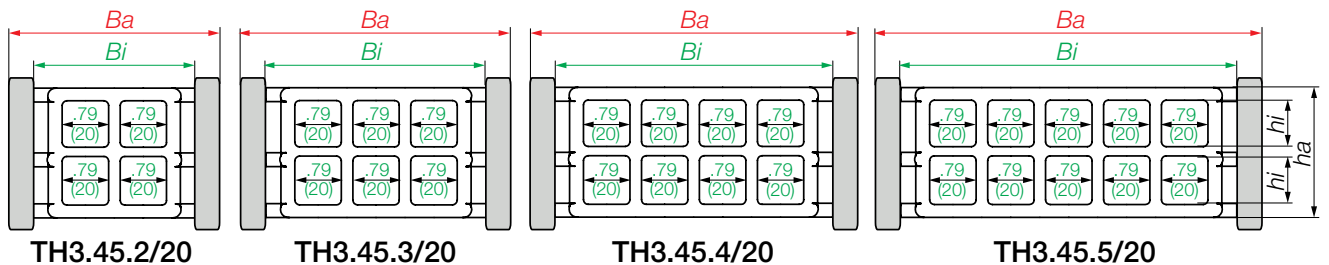

e-chain system® TH3
 Series TH3.45
 Interior Separation



TH3.45

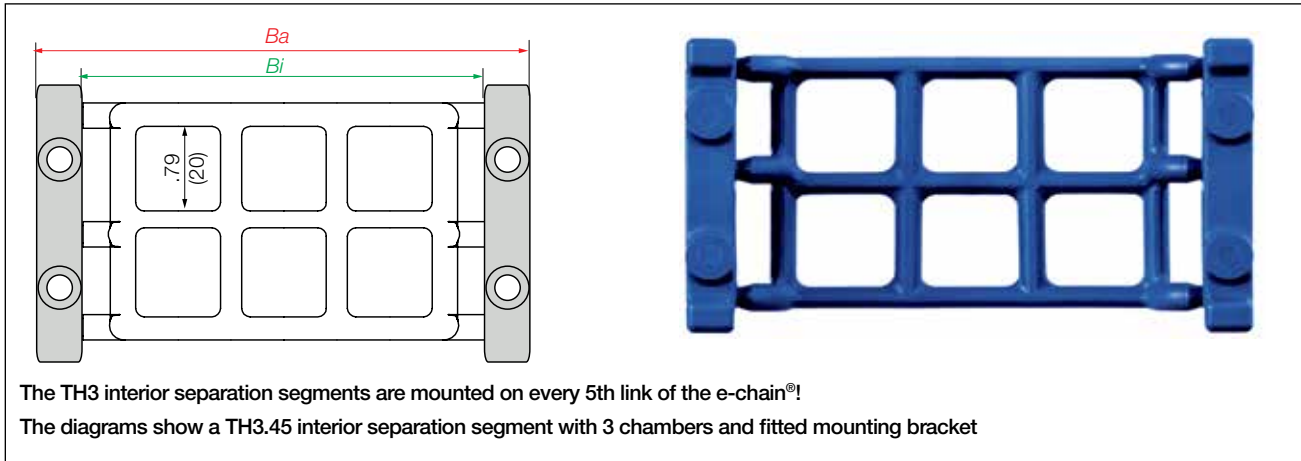

The TH3 interior separation segments are mounted on every 5th link of the e-chain®!
 The diagrams show a TH3.45 interior separation segment with 3 chambers and fitted mounting bracket

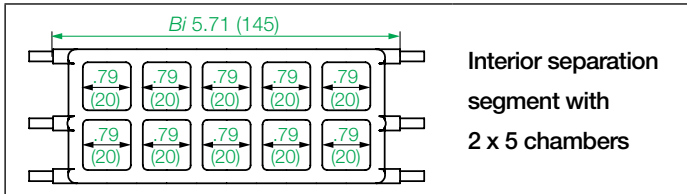
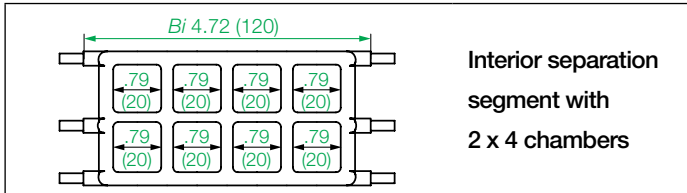
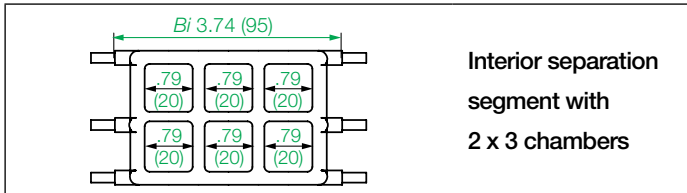
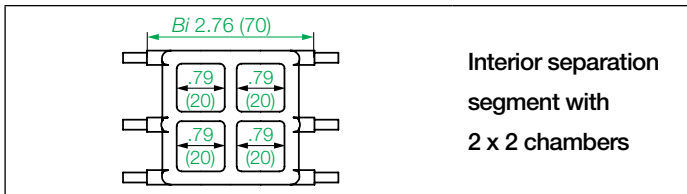

The TH3 series is suitable for applications with the highest hygienic requirements for safe cable and hose guidance

PDF: igus.com/e-chain-pdfs
 Product information: igus.com/e-chains



FDA-compliant mounting brackets, locking - Attachment from any side

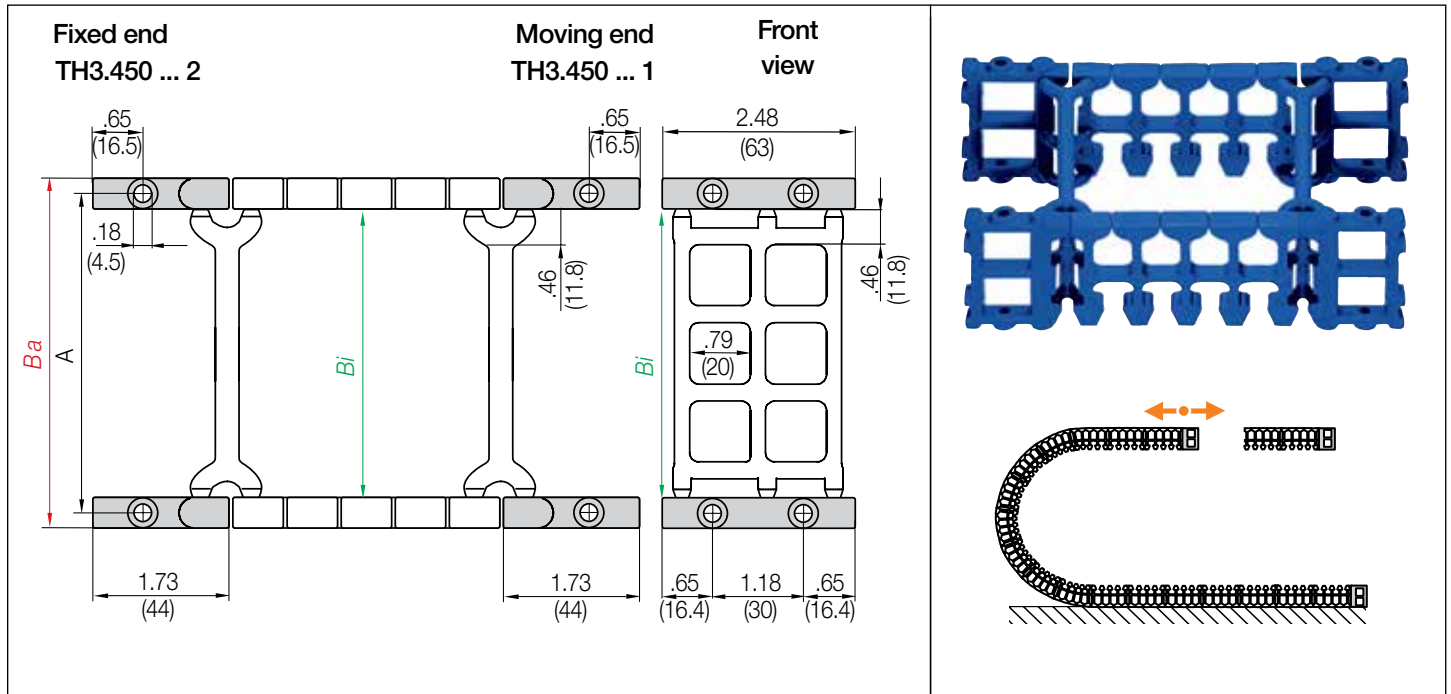

FDA-compliant mounting brackets, locking

Width index	Part No. full set locking	A in. (mm)	Bi in. (mm)	Ba in. (mm)
2/20 ▶	TH3.450.2/20.12.8	3.15 (80)	2.76 (70)	3.54 (90)
3/20 ▶	TH3.450.3/20.12.8	4.13 (105)	3.74 (95)	4.53 (115)
4/20 ▶	TH3.450.4/20.12.8*	5.12 (130)	4.72 (120)	5.51 (140)
5/20 ▶	TH3.450.5/20.12.8*	6.10 (155)	5.71 (145)	6.50 (165)

*Width available upon request. Please consult igus® for delivery time.



The TH3 e-chain® is the world's first plastic e-chain® developed according to "Hygienic Design Guidelines" (04/2018)

PDF: igus.com/e-chain-pdfs
Product information: igus.com/e-chains



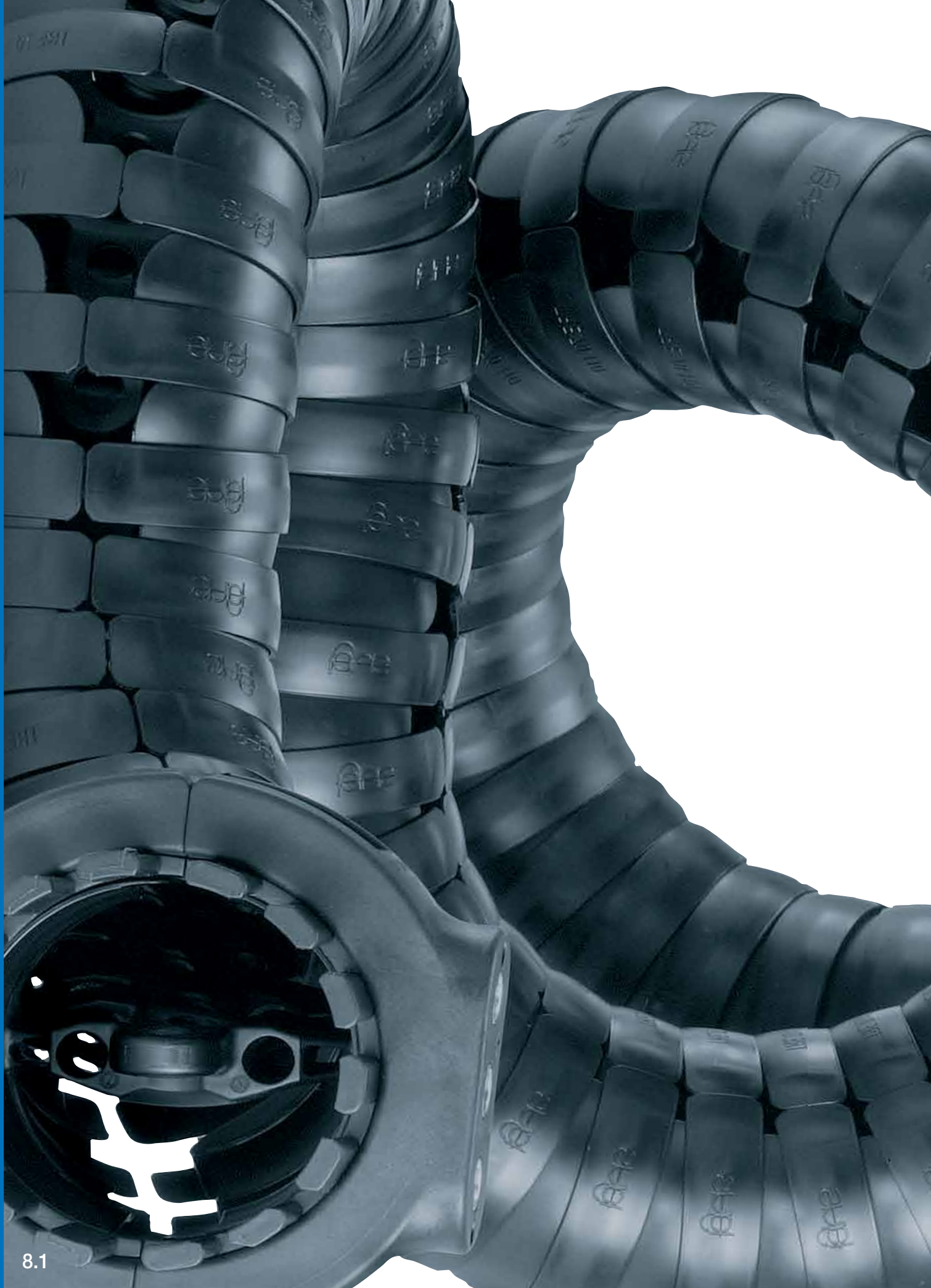



igus[®] 3-D e-chains[®]

Robotic, 3D and
circular movements:
triflex[®]
twisterchain
twisterband

triflex® R, E-Z triflex® and triflex® e-chains® for Robotic and 3D Applications



triflex® R - 3D-robotic e-chains®

- The first choice for multi-axis-robots
- **TRC version** - closed design with smooth and robust exterior
- **TRCF version** - closed design with snap-open mechanism
- **TRE version** - “easy” design, easy to fill from outside
- **TRL version** - light weight, cost-efficient and very easy to fill, for non robotic applications
- **TRLF version** - light weight, snap-open mechanism
- Torsion approximately $\pm 10^\circ$ per link possible
- High torsional stability (TRC/TRE)
- Easy shortening and lengthening
- Small bending radius, small pitch

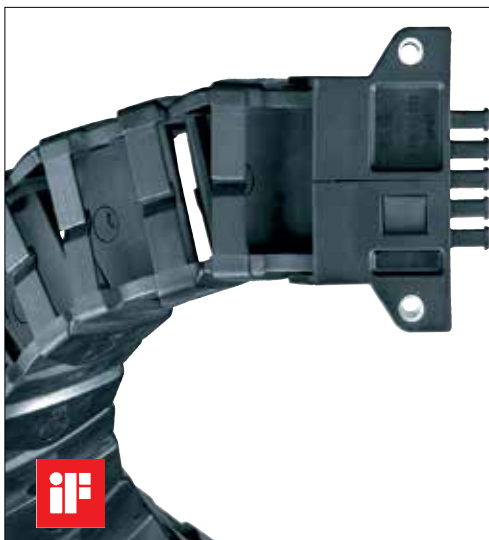

E-Z triflex® - easy filling

- Easy filling from two sides and complex movements
- For reparations or supplements of existing triflex® Systems
- For simple robotic- and 3D-applications
- Fast cable assembly with “easy” design
- Where rectangular shapes fit better
- Combination of different bending radii and movement directions possible
- Shortening and lengthening anywhere
- 3D e-chain® for non robotic applications



triflex® - enclosed version

- 3-axis motions in machinery of all kinds (combined circle- and stroke-movements)
- Completely enclosed - protection against dirt and chips
- For simple 3D-applications
- High tensile strength
- Where rectangular shapes fit better
- Modular, robust
- Combinations of varying bending radii and moving axes possible
- 3D e-chain® for non robotic applications
- Connecting, separating possible at every link

twisterchain® and twisterband e-chains® for Circular and Spiral Movements



twisterchain® circular and spiral e-chains®

- e-chains® for circular and spiral movements up to 360° available from stock
- Tough, quiet and high dynamics. suitable for high fill weights
- Rotary speeds up to 3.28 ft/s (1 m/s) and more
- Modular interior separation
- Smooth cable-friendly interior
- Openable from both sides - crossbars removable along the inner and outer radius



twisterband - rotary motions

- Rotary motions in a small spaces
- 4 sizes available
- Rotary movements up to 7000°
(Installation position, vertical: up to 3.000°, horizontal 7.000° and more possible)
- Rotary speeds up to 360°/s possible
- Compact, modular and lightweight
- Ribbons can be shortened easily
- Minimum installation space
- Can be used in various installation positions
- Cost-effective







triflex[®] R

For multi-axis movements and robots



triflex[®] R advantages:

- For the most demanding multi-axis applications on industrial robots
- Defined torsion stop-dog
- Defined minimum bend radius
- Easy to lengthen and shorten
- Small bend radius and short pitch
- Fillable from the outside



When to use another 3D e-chain[®] series:

- For circular movements with high loads
 - ▶ **twisterchain system**

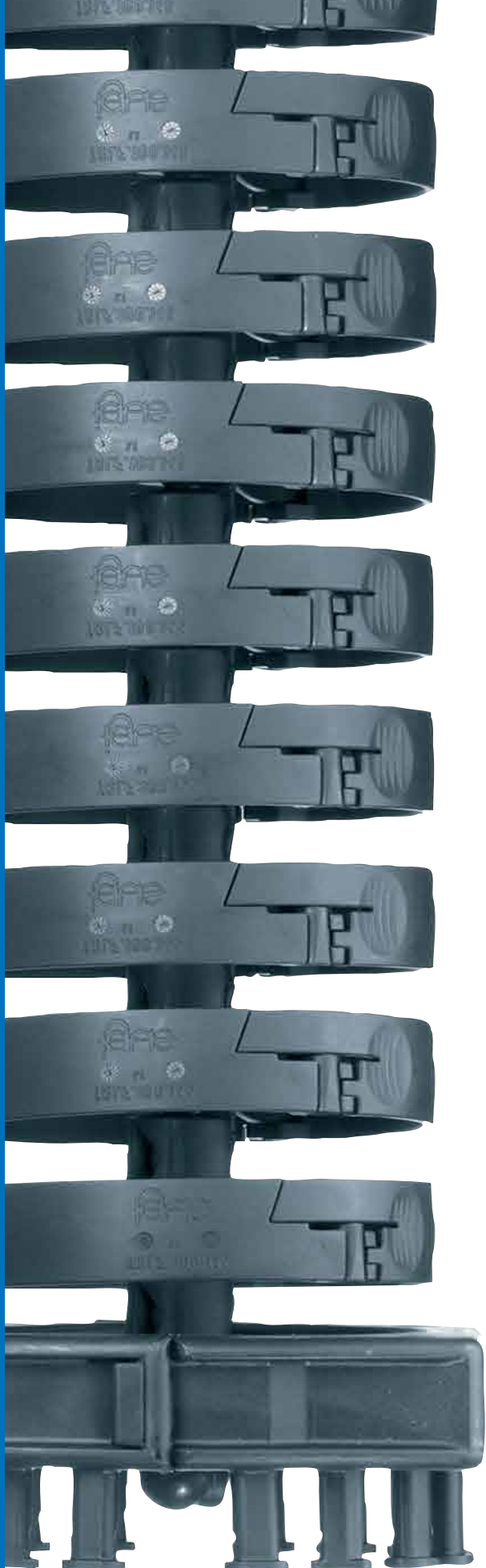

For multi-axis movements and robots - triflex® R

triflex® R (R for “round”) is the third generation of multi-axis e-chains®. The key design characteristics of igus® triflex® R have made this product very successful in the robot industry.

- Defined torsion stop-dog on each e-chain® link
- Defined minimum bend radius
- High tensile strength ball and socket joint
- Compact retraction system options to prevent loop formation
- Fiber-rod option for partial directional control and reinforcement
- No extra support elements required e.g. steel cables, spring suspensions etc.
- Wide range of accessories

The triflex® R product family is available in 5 versions from stock:

- TRC - closed design with a smooth and robust exterior
- TRCF - closed design with snap-open mechanism
- TRE - “easy” design, simply press the cables in
- TRL - lightweight, also features “easy design”
- TRLF - Light version with snap lock mechanism

Typical industries and applications

- Robotics/Automation
- Machine tools
- Handling machines - 6-axis
- Packaging machines
- General mechanical engineering, etc.



Assembly video available online at
▶ www.igus.com/triflexR_assembly



Available from stock. **Orders ship as early as today.***

*On average 90% of orders ship the same day..

triflex® R - Features - Accessories



The defined torsion stop ensures an even distribution of the torsional load across the entire length



A tough, bend radius stop-dog actively prevents cables and hoses from kinking



Interior separation: two or three chamber design for a reliable cable guidance



Openable - series TRCF and TRLF have snap lock mechanism for easy filling



Tensile strength is absorbed directly by the e-chain® - no additional supports are necessary

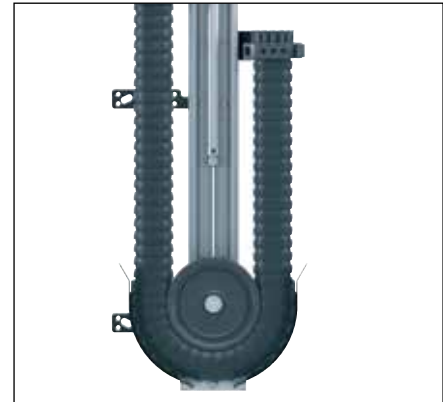

5 retraction system options available to prevent formation of loops in the robot's working area



Standard and light mounting brackets available with or without integrated strain relief. Some versions available in ESD material, from stock



Mounting brackets options with gliding feed-through and swivel bearing. Bearing with a maintenance-free igubal® ball and socket joint



Various heavy duty and compact connections and quick-change units are available



Series TRC - Electrically conductive ESD e-chains® - several series available from stock



UL94-V2 classification



IF product design awards

2004 for igus® series TRC
2007 for igus® series TRL
2013 for igus® series TRLF

triflex® R - Selection Guide

Series	Inner height				max. cable ø				Outer width		Bend radius		Pitch		Links	
	Bi 1		Bi 2		d1		d2		Ba		R		in.	(mm)	per ft	per m
	in.	(mm)	in.	(mm)	in.	(mm)	in.	(mm)	in.	(mm)	in.	(mm)				



Series TRC - closed design
chip protection,
smooth outer contour

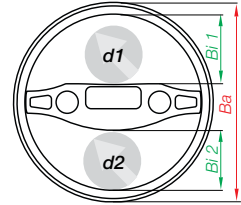

TRC-30	.47	(12)	.39	(10)	.39	(10)	.31	(8)	1.36	(34.5)	1.97	(50)	.44	(11.3)	27.27	(89)
TRC-40	.59	(15)	.51	(13)	.51	(13)	.43	(11)	1.69	(43)	2.28	(58)	.55	(13.9)	21.82	(72)
TRC-50	.74	(18.8)	.64	(16.2)	.65	(16.5)	.55	(14)	2.13	(54)	3.15	(80)	.69	(17.4)	17.39	(58)
TRC-60	.88	(22.5)	.77	(19.5)	.81	(20.5)	.69	(17.5)	2.56	(65)	3.43	(87)	.80	(20.4)	15.00	(49)
TRC-70	1.10	(28)	.94	(24)	1.02	(26)	.87	(22)	3.19	(81)	4.33	(110)	1.01	(25.6)	11.88	(39)
TRC-85	1.30	(33)	1.10	(28)	1.22	(31)	1.02	(26)	3.72	(94.5)	5.31	(135)	1.20	(30.6)	10.00	(33)
TRC-100	1.48	(37.5)	1.28	(32.5)	1.40	(35.5)	1.20	(30.5)	4.25	(108)	5.71	(145)	1.36	(34.5)	8.82	(29)
TRC-125 ³⁾	1.70	(43.3)	1.70	(43.3)	1.61	(41)	1.61	(41)	5.31	(135)	7.17	(182)	1.76	(44.6)	6.82	(23)



Series TRE - "easy" design
very easy to fill, cables
are simply pushed in

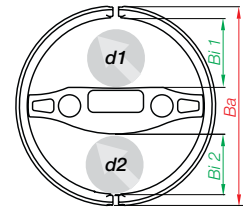

TRE-30	.47	(12)	.39	(10)	.39 ¹⁾	(10) ¹⁾	.31 ¹⁾	(8) ¹⁾	1.36	(34.5)	1.97	(50)	.44	(11.3)	27.27	(89)
TRE-40	.59	(15)	.51	(13)	.51 ¹⁾	(13) ¹⁾	.43 ¹⁾	(11) ¹⁾	1.69	(43)	2.28	(58)	.55	(13.9)	21.82	(72)
TRE-50	.74	(18.8)	.64	(16.2)	.65 ¹⁾	(16.5) ¹⁾	.55 ¹⁾	(14) ¹⁾	2.13	(54)	3.15	(80)	.69	(17.4)	17.39	(58)
TRE-60	.88	(22.5)	.77	(19.5)	.81 ¹⁾	(20.5) ¹⁾	.69 ¹⁾	(17.5) ¹⁾	2.56	(65)	3.43	(87)	.80	(20.4)	15.00	(49)
TRE-70	1.10	(28)	.94	(24)	1.02 ¹⁾	(26) ¹⁾	.87 ¹⁾	(22) ¹⁾	3.19	(81)	4.33	(110)	1.01	(25.6)	11.88	(39)
TRE-85	1.30	(33)	1.10	(28)	1.22 ¹⁾	(31) ¹⁾	1.02 ¹⁾	(26) ¹⁾	3.72	(94.5)	5.31	(135)	1.20	(30.6)	10.00	(33)
TRE-100	1.48	(37.5)	1.28	(32.5)	1.40 ¹⁾	(35.5) ¹⁾	1.20 ¹⁾	(30.5) ¹⁾	4.25	(108)	5.71	(145)	1.36	(34.5)	8.82	(29)
TRE-125 ³⁾	1.70	(43.3)	1.70	(43.3)	1.61 ¹⁾	(41) ¹⁾	1.61 ¹⁾	(41) ¹⁾	5.31	(135)	7.17	(182)	1.76	(44.6)	6.82	(23)



Series TRCF - closed design with snap lock mechanism
chip protection,
smooth outer contour

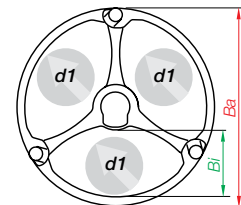

TRCF-65	.88	(22.3)			.79	(20)			2.76	(70.2)	3.94	(100)	.91	(23.1)	13.19	(44)
TRCF-65 ⁴⁾	.88	(22.3)			.79	(20)			2.76	(70.2)	7.87	(200)	.91	(23.1)	13.19	(44)
TRCF-85	1.18	(30)	—	—	1.10	(28)	—	—	3.72	(94.5)	5.31	(135)	1.20	(30.6)	10.00	(33)
TRCF-85 ⁴⁾	1.18	(30)			1.10	(28)			3.72	(94.5)	9.45	(240)	1.20	(30.6)	10.00	(33)
TRCF-100	1.35	(34.3)	—	—	1.27	(32.3)	—	—	4.25	(108)	5.71	(145)	1.35	(34.4)	8.89	(29)

- 1) For quick and easy fitting or removal of cables using the "easy" design, we recommend a maximum cable diameter of 70% of the specified value
- 2) Max. cable diameter Ø 1.61" (41mm). Max. cable diameter changes to Ø 1.42" (36 mm), if lengthening or shortening an already populated triflex® R
- 3) TRL 30 with 2-chamber design
- 4) Special size with increased bend radius and special range of accessories

Series	Inner height				max. cable ø				Outer width		Bending radii		Pitch		Links	
	Bi 1		Bi 2		d1		d2		Ba		R		in.	(mm)	per ft	per m
	in.	(mm)	in.	(mm)	in.	(mm)	in.	(mm)	in.	(mm)	in.	(mm)				



Series TRL -
the “light” version with
“easy” design
easy to fill and cost effective

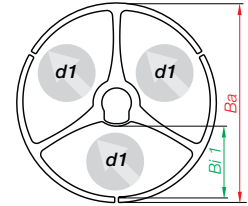

TRL-30 [®]	.47	(12)	.39	(10)	.39	(10*)	.31	(8*)	1.36	(34.5)	1.97	(50)	.44	(11.3)	27.27	(89)
TRL-40	.59	(15)	-	-	.51	(13*)	-	-	1.69	(43)	2.28	(58)	.55	(13.9)	21.82	(72)
TRL-60	.91	(23)	-	-	.81	(20.5*)	-	-	2.56	(65)	3.43	(87)	.80	(20.4)	15.00	(49)
TRL-70	1.10	(28)	-	-	1.02	(26*)	-	-	3.19	(81)	4.33	(110)	1.01	(25.6)	11.88	(39)
TRL-100	1.50	(38)	-	-	1.40	(35.5*)	-	-	4.25	(108)	5.31	(145)	1.36	(34.5)	8.82	(29)



Series TRLF -
the “light” version with
snap lock mechanism
lightweight and cost effective

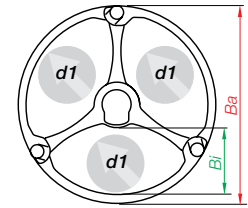

TRLF-65	.96	(24.4)	-	-	.87	(22)	-	-	2.76	(70.2)	3.94	(100)	.91	(23.1)	13.19	(44)
TRLF-85	1.29	(32.8)	-	-	1.18	(30)	-	-	3.72	(94.5)	5.31	(135)	1.20	(30.6)	10.00	(33)
TRLF-100	1.48	(37.5)	-	-	1.40	(35.5)	-	-	4.25	(108)	5.71	(145)	1.35	(34.4)	8.89	(29)
TRLF-125	1.84	(46.8)	-	-	1.75	(44.5)	-	-	5.31	(135)	7.17	(182)	1.74	(44.1)	6.90	(23)

triflex® R - Retraction system overview

Series	System	For triflex® R	
		e-chains®	For ø Index
		in.	(mm)
	RSE linear - retraction system	TRC-TRE-TRCF	1.57 - 4.92 (40 - 100)
	RS - modular retraction system	TRC-TRE	1.57 - 3.94 (40 - 100)
	RSP - pneumatic retraction system	TRC-TRE-TRCF	2.36 - 4.92 (60 - 125)
	RSE Wheel- retraction system	TRC-TRE	1.57 - 1.97 (40 - 50)
	RSEL linear- retraction system	TRC-TRE-TRCF	2.76 - 3.35 (70-85)

Technical data

 Speed / acceleration upon request

 Material - permitted temperature, igumid G (TRLF/TRCF) -40°F / +248°F (-40°C / +120°C)

Material - permitted temperature, igumid NB (TRC/TRE/TRL) -40°F / +176°F (-40°C / +80°C)

 Flammability class, igumid G (TRLF/TRCF) VDE 0304 IIC UL94-HB

Flammability class, igumid NB (TRC/TRE/TRL) VDE 0304 IIC UL94-V2

Reduce installation times with easy-to-use disassembly tools



Easy-to-use disassembly tools for triflex® TRE (B version) and TRCF. Easy disassembly at any point along the e-chain®, even when full.

More information

► www.igus.com/triflex_B_disassemblytool

 Assembly video available online at
► www.igus.com/triflexR_assembly

For series	Part No.
TRE-B	disassembly tool
TRE-40-B	MAT0050175
TRE-50-B	MAT0051190
TRE-60-B / TRE-70-B	MAT0051135
TRE-85-B	MAT0050170
TRE-100-B	MAT0050172

For series	Part No.
TRCF	disassembly tool
TRCF-65	MAT0051135
TRCF-85	MAT0050170
TRCF-100	MAT0050172



igus® triflex® R TRLF - light version, easily openable by hand or with a screwdriver

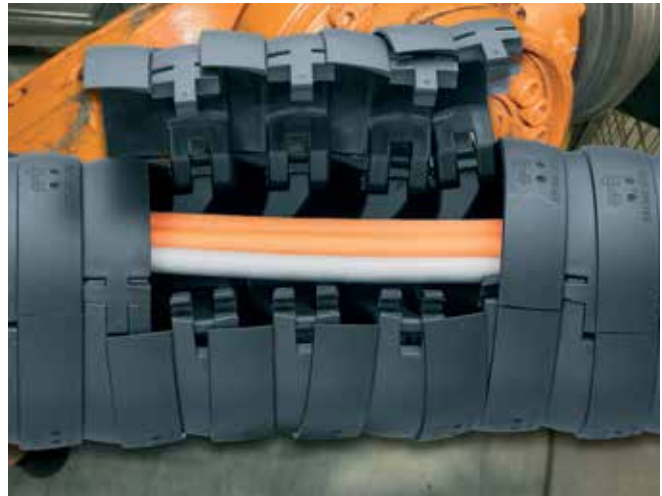

igus® triflex® R TRCF - closed version, openable with a screwdriver



triflex® RS for a low profile retraction system.. Integrated fiber rods generate the directed pretension so that loops do not form in the working area



Pneumatic retraction system triflex® RSP - prevents loop formation on the robot



triflex® TR-RSE-40-L or R, cost-effective and lightweight retraction system with guide roller, for small robots



TR-RSE linear retraction system for triflex® R, sizes 40-125

Closed and chip-repellent - TRC

TRC - enclosed, chip-repellent design

High tensile strength thanks to special ball and socket design

Defined torsion stop, allows free movement in any direction but still protects the cables

Impact-resistant, abrasion resistant and chip-resistant

Easy assembly and disassembly

High strength - thanks to external stop-dogs

Small bend radius and short pitch

Easy attachment and special accessories for the robot or machine

- Secure, closed and chip-repellent energy supply for multi-axis movements
- Smooth but robust exterior
- High torsional strength
- Easy to lengthen and shorten

Typical industries and applications

- Robotics and automation
- Multi-axis machine tools
- Wet and cold cells
- Painting applications and ESD
- Sand and dust exposure



Electrically conductive ESD e-chains® -



iF product design award

2004 igus® series TRC

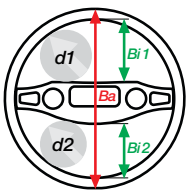

triflex® R - Series TRC - Product Range

Robotic applications, closed, chip repellent



TRC



e-tubes - Series TRC - Totally enclosed, non-openable

Series	Inner height				Max. cable ø				Outer width		Bend radius		Pitch		Links		Weight	
	Bi 1		Bi 2		d1		d2		Ba		R							
	in.	(mm)	in.	(mm)	in.	(mm)	in.	(mm)	in.	(mm)	in.	(mm)	in.	(mm)	per ft.	per m	lbs/ft	(kg/m)
TRC-30-050-0	.47	(12)	.39	(10)	.39	(10)	.31	(8)	1.36	(34.5)	1.97	(50)	.44	(11.3)	27.27	(89)	≈ 0.18	≈ 0.27
TRC-40-058-0 ¹⁾	.59	(15)	.51	(13)	.51	(13)	.43	(11)	1.69	(43)	2.28	(58)	.55	(13.9)	21.82	(72)	≈ 0.25	≈ 0.37
TRC-50-080-0	.74	(18.8)	.64	(16.2)	.65	(16.5)	.55	(14)	2.13	(54)	3.15	(80)	.69	(17.4)	17.39	(58)	≈ 0.40	≈ 0.59
TRC-60-087-0 ¹⁾	.88	(22.5)	.77	(19.5)	.81	(20.5)	.69	(17.5)	2.56	(65)	3.43	(87)	.80	(20.4)	15.00	(49)	≈ 0.57	≈ 0.85
TRC-70-110-0 ¹⁾	1.10	(28)	.94	(24)	1.02	(26)	.87	(22)	3.19	(81)	4.33	(110)	1.01	(25.6)	11.88	(39)	≈ 0.89	≈ 1.32
TRC-85-135-0	1.30	(33)	1.10	(28)	1.22	(31)	1.02	(26)	3.72	(94.5)	5.31	(135)	1.20	(30.6)	10.00	(33)	≈ 1.18	≈ 1.75
TRC-100-145-0	1.48	(37.5)	1.28	(32.5)	1.40	(35.5)	1.20	(30.5)	4.25	(108)	5.71	(145)	1.36	(34.5)	8.82	(29)	≈ 1.60	≈ 2.38
TRC-125-182-0	1.70	(43.3)	1.70	(43.3)	1.61	(41)	1.61	(41) ²⁾	5.31	(135)	7.17	(182)	1.76	(44.6)	6.82	(23)	≈ 3.16	≈ 4.70

1) Available as ESD version from stock

2) TRE 125 max. cable diameter Ø 1.61" (41mm). Max. cable diameter changes to Ø 1.42" (36mm) when an already populated e-chain needs to be shortened or lengthened

Installation dimensions

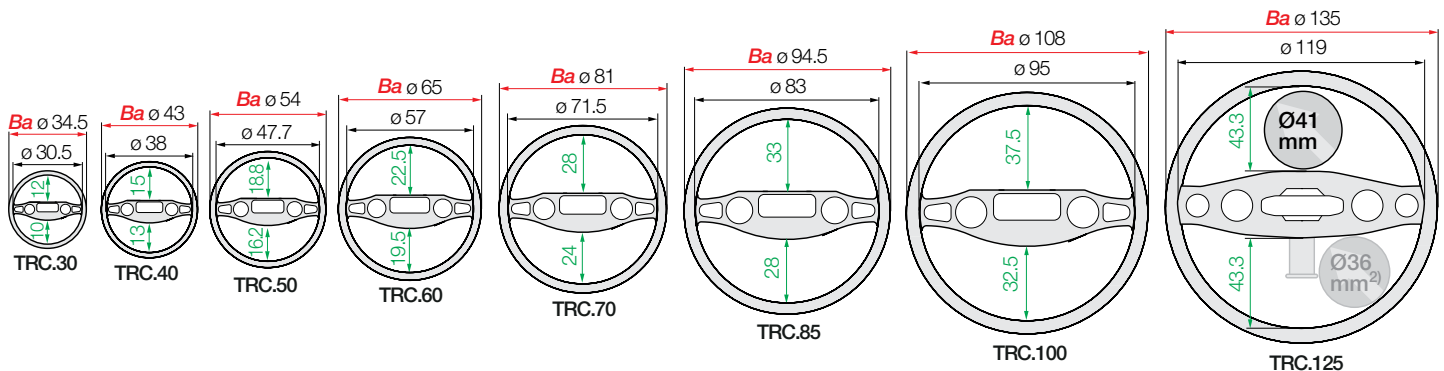

ESD - many sizes

- Standardized product made from igumid ESD
- ESD material tested with over 10 million cycles for the toughest requirements
- Short delivery times including mounting brackets and interior separation; 24hrs, from stock

More information ► www.igus.com/esd

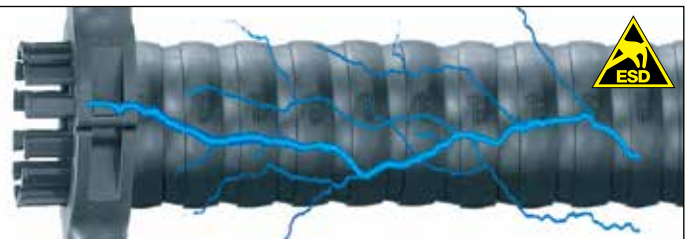

Easy to fill - simply press cables in - TRE

TRE - "easy" design - simply press cables in

High tensile strength thanks to special ball and socket design

Defined torsion stop, allows free movement in any direction but still protects the cables

"Easy" design for fast filling with cables and hoses

Simple tool for fast disassembly of the triflex® B versions

High strength - thanks to external stop-dogs

Small bend radius and short pitch

Easy attachment and special accessories for the robot or machine

- Easy to fill energy supply for multi-axis movements
- High torsional strength
- Easy to shorten and lengthen.
- **B version** - 4x increase in radial stability, allows larger torsion forces
- **C version TRE-100 and TRE-125** - fast assembly due to pin connection and spherical igubal® joint allowing 50% higher tensile forces

Typical industries and applications

- Robotics and automation
- Spot welding
- Pick and place applications
- When fast replacement is needed



Electrically conductive ESD e-chains® upon request



Save time - easy disassembly tool available for triflex® R



TRE - very easy to fill, cables are simply pushed in

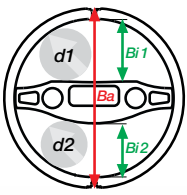

triflex® R - Series TRE - Product Range

Robotic applications, easy filling



TRE

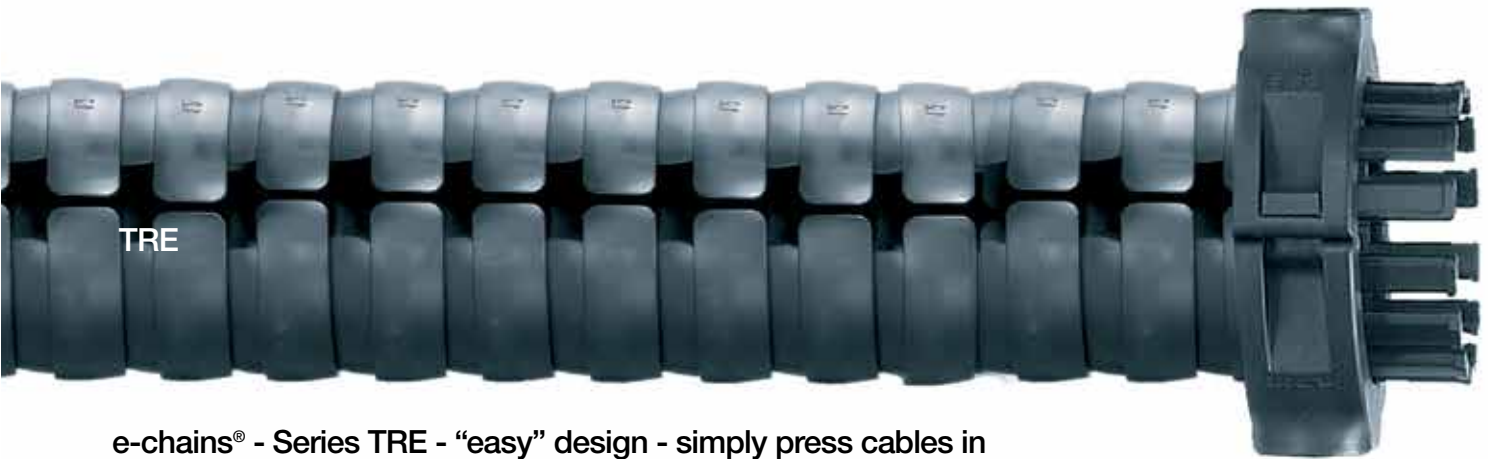

e-chains® - Series TRE - “easy” design - simply press cables in

Series	Inner height				Max. cable ø				Outer width		Bend radius		Pitch		Links		Weight	
	Bi 1		Bi 2		d1 ²⁾		d2 ²⁾		Ba		R		Pitch		Links		Weight	
	in.	(mm)	in.	(mm)	in.	(mm)	in.	(mm)	in.	(mm)	in.	(mm)	in.	(mm)	per ft.	per m	lbs/ft	(kg/m)
TRE-30-050-0	.47	(12)	.39	(10)	.39	(10*)	.31	(8*)	1.36	(34.5)	1.97	(50)	.44	(11.3)	27.27	(89)	≈ 0.18	≈ (0.27)
TRE-40-058-0-B	.59	(15)	.51	(13)	.51	(13*)	.43	(11*)	1.69	(43)	2.28	(58)	.55	(13.9)	21.82	(72)	≈ 0.25	≈ (0.37)
TRE-50-087-0-B	.74	(18.8)	.64	(16.2)	.65	(16.5)	.55	(14)	2.13	(54)	3.15	(80)	.69	(17.4)	17.39	(58)	≈ 0.38	≈ (0.56)
TRE-60-087-0-B	.88	(22.5)	.77	(19.5)	.81	(20.5)	.69	(17.5)	2.56	(65)	3.43	(87)	.80	(20.4)	15.00	(49)	≈ 0.57	≈ (0.85)
TRE-70-110-B	1.10	(28)	.94	(24)	1.02	(26)	.87	(22)	3.19	(81)	4.33	(110)	1.01	(25.6)	11.88	(39)	≈ 0.89	≈ (1.32)
TRE-85-135-B	1.30	(33)	1.10	(28)	1.22	(31)	1.02	(26)	3.72	(94.5)	5.31	(135)	1.20	(30.6)	10.00	(33)	≈ 1.18	≈ (1.75)
TRE-100-145-B/C ¹⁾	1.48	(37.5)	1.28	(32.5)	1.40	(35.5)	1.20	(30.5)	4.25	(108)	5.71	(145)	1.36	(34.5)	8.82	(29)	≈ 1.60	≈ (2.38)
TRE-125-182-0	1.70	(43.3)	1.70	(43.3)	1.61	(41)	1.61	(41) ³⁾	5.31	(135)	7.17	(182)	1.76	(44.6)	6.82	(23)	≈ 3.16	≈ (4.70)

B-Series = 4-x higher torsion forces **C-Series** = quick assembly, 50% higher forces

1) Available as **C-Version** Part No. **TRE-100-145-0-C**

2) For quick and easy fitting or removal of cables using the "easy" design, we recommend a maximum cable diameter of 70% of the specified value

3) TRE 125: max. cable diameter Ø 1.61" (41mm). Max. cable diameter changes to Ø 1.42" (36mm) when an already populated e-chain needs to be shortened or lengthened

Installation dimensions

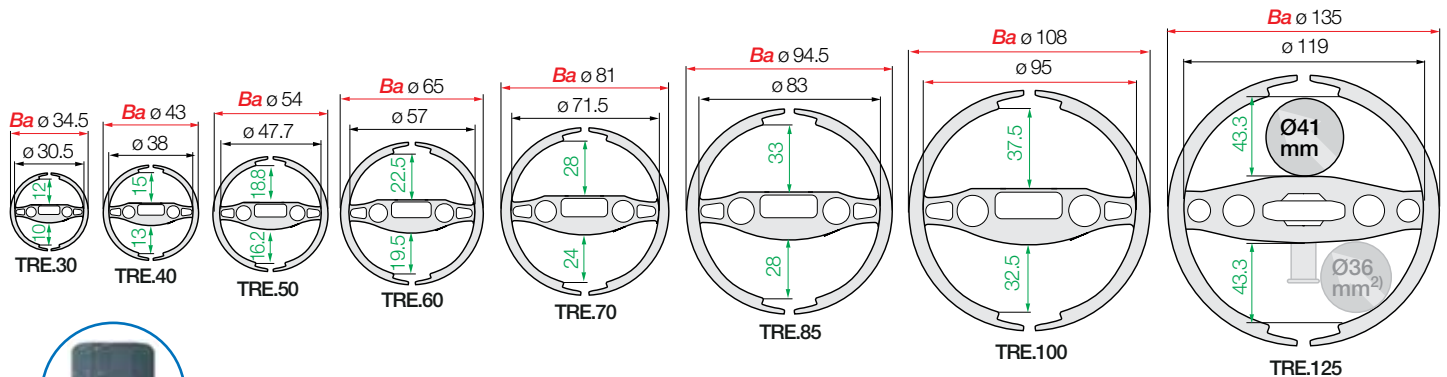

TRE-LOCK clips

Clips for a secure fit in the mounting bracket. Supplied with every mounting bracket. Please use the Part No. on the right for reordering individual parts

Part No. as an individual part	Size		Part No. as an individual part	Size	
	in.	(mm)		in.	(mm)
TRE.40.LOCK	1.18/1.57	(30/40)	TRE.70.LOCK	2.75/3.35	(70/85)
TRE.50.LOCK	1.97	(50)	TRE.100.LOCK	3.94	(100)
TRE.60.LOCK	2.36	(60)	TRE.125.LOCK	4.92	(125)

Easy to fill - simply press cables in - TRCF

TRCF - enclosed design with snap lock mechanism

High tensile strength thanks to special ball and socket design

Defined torsion stop, allows free movement in any direction but still protects the cables

Easy to open for large, stiff hoses or many cables

Easy assembly and disassembly - 4-piece, with openable lids

Impact-resistant and chip-resistant

3-chamber design for interior separation

Small bend radius and short pitch

Mounting bracket with strain relief also available as intermediate bracket

- Snap lock mechanism for fast opening to insert large cables or hoses
- Snap lock mechanism openable with a screwdriver
- Defined minimum bend radius and torsion stop-dog for optimum cable protection
- Enclosed version, for use with dirt and chip exposure
- 3 chamber design for ideal cable distribution and separation
- Easy to lengthen and shorten

Typical industries and applications

- Robotics and automation
- Painting applications
- Large hydraulic hoses
- Screw and rivet feeds
- Tool changer applications
- Laser welding applications
- Screw and rivet applications



Save time - easy disassembly tool available for triflex® R



Flip open, insert cable, and close snap lock mechanism - then ready to run!

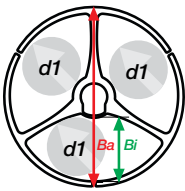

triflex® R - Series TRCF - Product Range

Closed design, chip-resistant, quick filling



TRCF



e-tubes - Series TRCF - Fully enclosed design, with snap lock mechanism

Series	Inner height		max. cable ϕ		Outer width		Bending radii		Pitch		Links		Weight	
	Bi		$d1$		Ba		R				per ft.	per m	in.	(mm)
	in.	(mm)	in.	(mm)	in.	(mm)	in.	(mm)	in.	(mm)				
TRCF-65-100-0	0.88	(22.3)	.79	(20)	2.76	(70.2)	3.94	(100)	0.91	(23.1)	13.19	(44)	\approx 0.74	\approx (1.10)
TRCF-65-200-0	0.88	(22.3)	.79	(20)	2.76	(70.2)	7.87	(200)	0.91	(23.1)	13.19	(44)	\approx 0.74	\approx (1.10)
TRCF-85-135-0	1.18	(30)	1.10	(28)	3.72	(94.5)	5.31	(135)	1.20	(30.6)	10.00	(33)	\approx 1.41	\approx (2.10)
TRCF-85-240-0 ¹⁾	1.18	(30)	1.10	(28)	3.72	(94.5)	9.45	(240)	1.20	(30.6)	10.00	(33)	\approx 1.41	\approx (2.10)
TRCF-100-145-0	1.35	(34.3)	1.27	(32.3)	4.25	(108)	5.71	(145)	1.36	(34.5)	8.82	(29)	\approx 1.81	\approx (2.70)

1) Special size Part No. TRCF-85-240-0 with 240 degree bend radius and a range of accessories

Installation dimensions

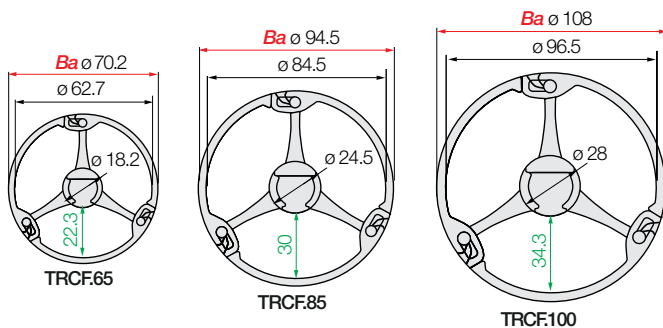

Snap lock mechanism for fast opening, video online

► www.igus.com/TRCF

Special sizes TRCF-65-200-0 and TRCF-85-240-0

- For secure guidance of fiber optic laser welding cables
- The large bend radius R 7.87" and 9.45" (200mm and 240mm) increases the service life of the fiber optic laser welding cable by preventing kinking

More information ► www.igus.com/TRCF



Lightweight and cost-effective - TRL

TRL - light and cost-effective with "easy" design

High tensile strength thanks to special ball and socket design

Defined torsion stop, allows free movement in any direction but still protects the cables

"Easy" design for fast filling with cables and hoses

Easy assembly and disassembly

Extremely lightweight due to one-piece design

Small bend radius and short pitch

Mounting bracket with strain relief also available as intermediate bracket

- Very easy to fill
- Multi-axis e-chain® for simple applications
- Easy to lengthen and shorten

Typical industries and applications

- Robot axes 1-3
- Non-robotic applications
- Bundling cables for operator controls
- Filament feeds on 3D printers
- Office applications



iF product design award

2007 igus® series TRL

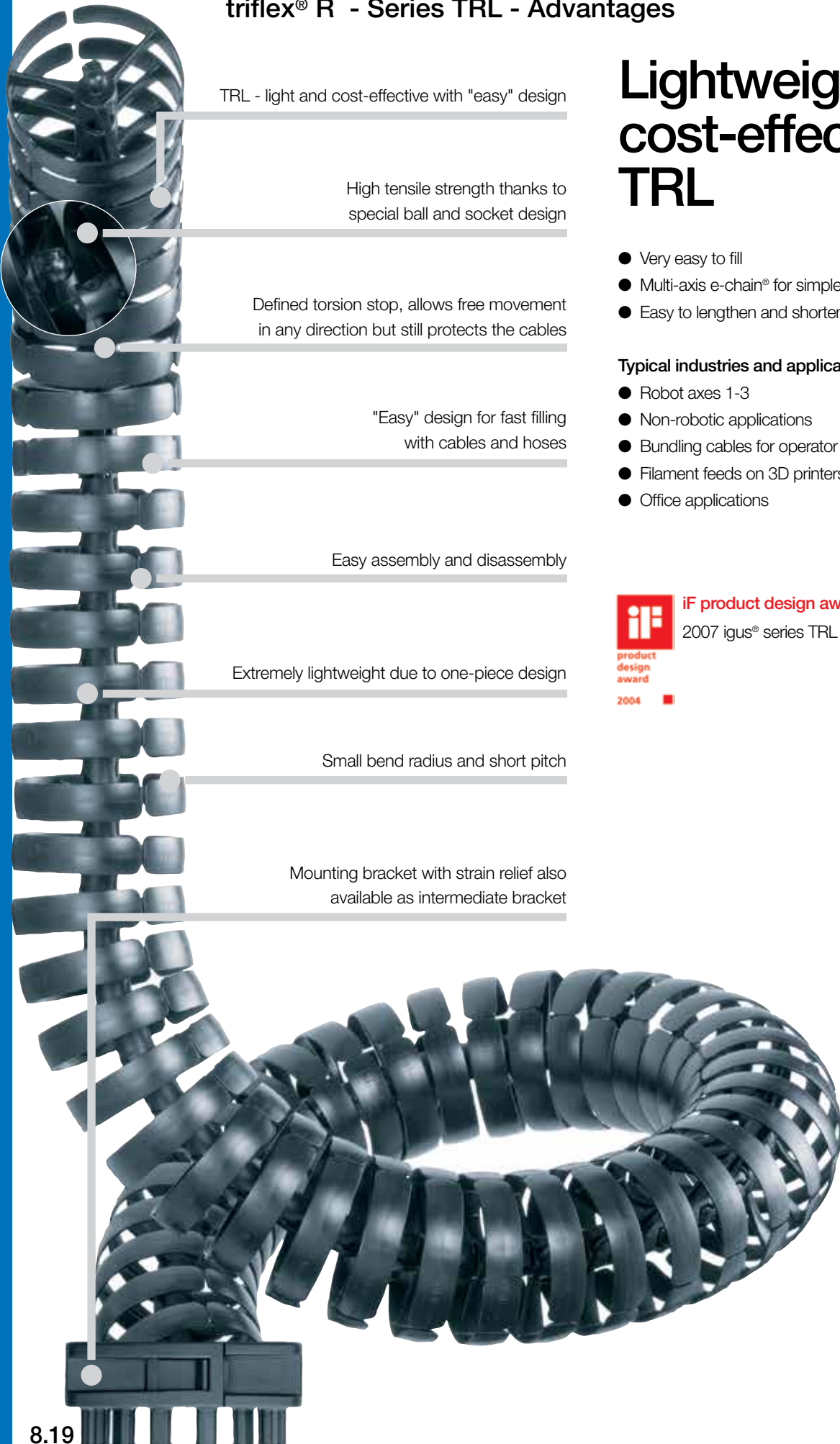

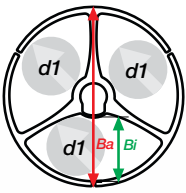

triflex® R - Series TRL - Product Range

Robotic applications, light and cost-effective



TRL



e-chains® - TRL series - Light version with "easy" design - simply press cables in

Series	Inner height				max. cable ø				Outer width		Bend radius		Pitch		Links		Weight	
	Bi 1		Bi 2		d1 ²⁾		d2 ²⁾		Ba		R		Pitch		Links		Weight	
	in.	(mm)	in.	(mm)	in.	(mm)	in.	(mm)	in.	(mm)	in.	(mm)	in.	(mm)	per ft.	per m	lbs/ft	kg/m
TRL-30-050-0 ¹⁾	.47	(12)	.43	(11)	.39	(10)	.31	(8)	1.36	(34.5)	1.97	(50)	.44	(11.3)	27.27	(89)	≈ 0.18	≈ 0.27
TRL-40-058-0	.59	(15)	–		.51	(13)	–		1.77	(45)	2.28	(58)	.55	(13.9)	21.82	(72)	≈ 0.25	≈ 0.37
TRL-60-087-0	.91	(23)	–		.81	(20.5)	–		2.56	(65)	3.43	(87)	.80	(20.4)	15.00	(49)	≈ 0.57	≈ 0.85
TRL-70-110-0	1.10	(28)	–		1.02	(26)	–		3.19	(81)	4.33	(110)	1.01	(25.6)	11.88	(39)	≈ 0.89	≈ 1.32
TRL-100-145-0	1.50	(38)	–		1.40	(35.5)	–		4.25	(108)	5.71	(145)	1.36	(34.5)	8.82	(29)	≈ 1.60	≈ 2.38

1) Only available with 2-chamber design

2) For quick and easy fitting or removal of cables using the "easy" design, we recommend a maximum cable diameter of 70% of the specified value

Installation dimensions

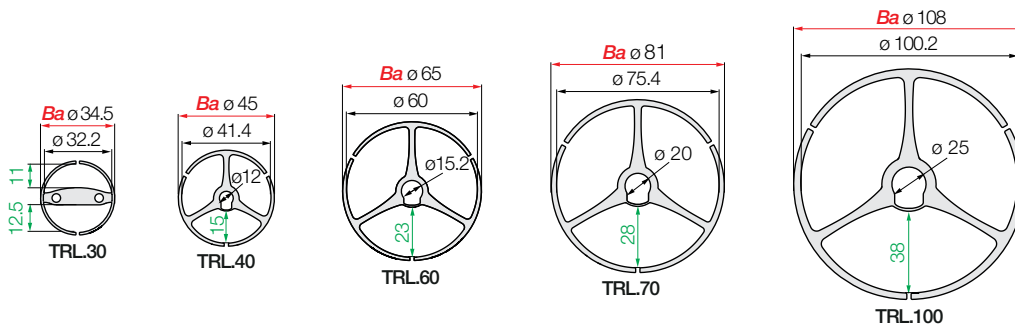

Lightweight with snap lock mechanism - TRLF

TRLF - light and cost-effective
with snap lock mechanism

High tensile strength thanks to
special ball and socket design

Defined torsion stop, allows free movement
in any direction but still protects the cables

Easy to open for large, stiff hoses or many cables

Easy assembly and disassembly

3-chamber design for interior separation

Small bend radius and short pitch

Lightweight mounting bracket available
with strain relief or as intermediate bracket

- Snap lock mechanism for fast opening
- Openable by hand or with a screwdriver
- For large, stiff hoses or many cables
- Economical multi-axis e-chain® for less demanding applications
- Easy to lengthen and shorten

Typical industries and applications

- Painting hoses
- Rivet feeds
- Robot axes 1-3
- Non-robotic applications
- Special machine construction
- High-tech design



Flip open, insert cable, and
close snap lock mechanism -
then ready to run!

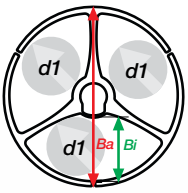

triflex® R - Series TRLF - Product Range

Quick filling with larger hoses and cables



TRLF



e-chains® - TRLF series - Light version with snap lock mechanism

Series	Inner height		max. cable ø		Outer width		Bend radius		Pitch		Links		Weight	
	<i>Bi 1</i>		<i>d1</i>		<i>Ba</i>		<i>R</i>				per ft.	per m	lbs/ft	kg/m
	in.	(mm)	in.	(mm)	in.	(mm)	in.	(mm)	in.	(mm)				
TRLF-65-100-0	.96	(24.4)	.87	(22)	2.76	(70.2)	3.94	(100)	.91	(23.1)	13.2	(44)	≈ 0.53	≈ 0.79
TRLF-85-135-0	1.29	(32.8)	1.18	(30)	3.72	(94.5)	5.31	(135)	1.20	(30.6)	10.0	(33)	≈ 0.97	≈ 1.45
TRLF-100-145-0	1.48	(37.5)	1.40	(35.5)	4.25	(108)	5.71	(145)	1.36	(34.5)	8.8	(29)	≈ 1.28	≈ 1.90
TRLF-125-182-0	1.84	(46.8)	1.75	(44.5)	5.31	(135)	7.17	(182)	1.74	(44.1)	6.9	(23)	≈ 2.78	≈ 4.13

Installation dimensions

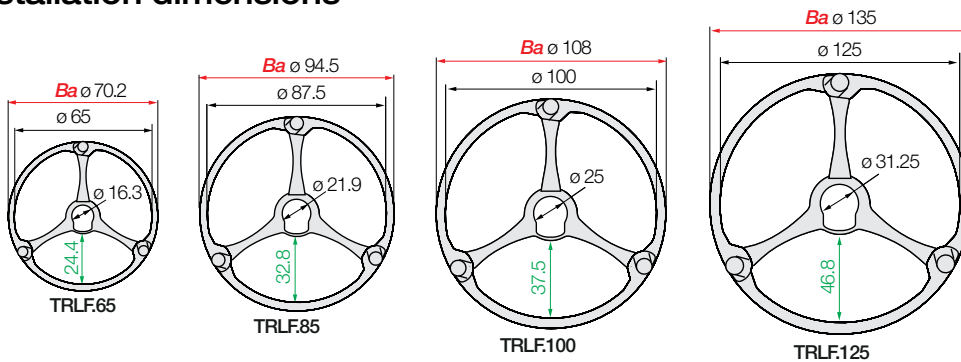

Snap lock mechanism for fast opening, video online

► www.igus.com/TRLF

With integrated strain relief tiewrap plates
TR.40.01 / TR.100.01

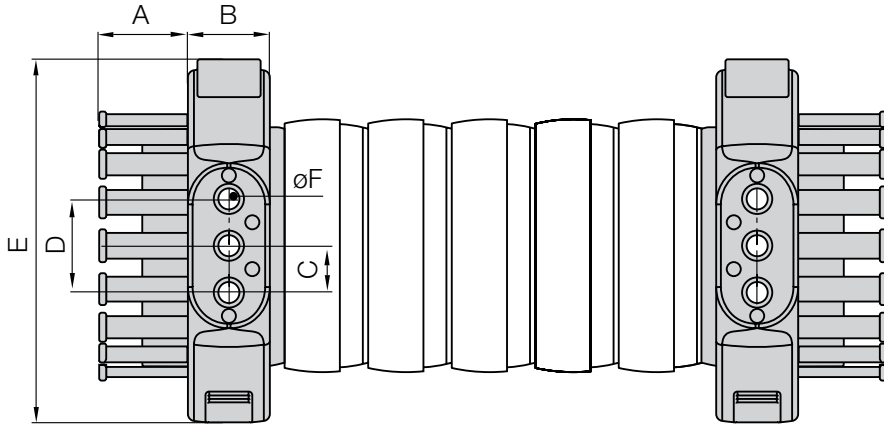

- Recommended for TRC/TRE/TRCF, also compatible with TRL/TRLF
- Standard fixation onto the robot or machine, with strain relief

Standard mounting brackets - With strain relief



TR.40.01 –
TR.100.01

Index	Part No. with strain relief	A		B		C		D		E		F	
		in.	(mm)	in.	(mm)	in.	(mm)	in.	(mm)	in.	(mm)	in.	(mm)
30.	▶ Alternative: light mounting bracket	-	-	-	-	-	-	-	-	-	-	-	-
40.	▶ TR.40.01.M6 ¹⁾²⁾	.70	(17.8)	.83	(21)	.53	(13.5)	1.06	(27)	3.33	(84.5)	.26	(6.5)
50.	▶ TR.50.01.M6 ¹⁾	.83	(21)	.83	(21)	.53	(13.5)	1.06	(27)	3.33	(84.5)	.26	(6.5)
60.	▶ TR.60.01.M8 ¹⁾²⁾	.98	(25)	1.26	(32)	.79	(20)	1.57	(40)	4.96	(126)	.35	(9)
65.	▶ TR.65.01.M8 ⁵⁾	.98	(25)	1.26	(32)	.79	(20)	1.57	(40)	4.96	(126)	.35	(9)
70.	▶ TR.70.01.M8 ¹⁾²⁾	.98	(25)	1.26	(32)	.79	(20)	1.57	(40)	4.96	(126)	.35	(9)
85.	▶ TR.85.01.M8 ¹⁾	1.50	(38)	1.38	(35)	.79	(20)	1.57	(40)	6.10	(155)	.35	(9)
85. (R 240)	▶ TR.85.240.01.M8 ¹⁾	1.50	(38)	1.38	(35)	.79	(20)	1.57	(40)	6.10	(155)	.35	(9)
100.	▶ TR.100.01.M8 ¹⁾	1.50	(38)	1.38	(35)	.79	(20)	1.57	(40)	6.10	(155)	.35	(9)
125.	▶ Alternative: standard mounting bracket without strain relief	-	-	-	-	-	-	-	-	-	-	-	-

Strain relief is for use on the fixed end and/or moving end.

Standard: through holes in Ø F - 1) option: with threaded bushings, steel, M6/M8

2) Available as ESD version from stock

5) Available for delivery upon request. Please consult igus® for delivery time.

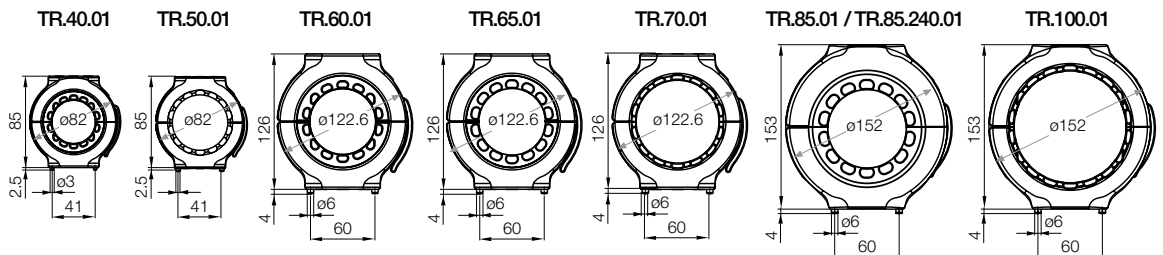

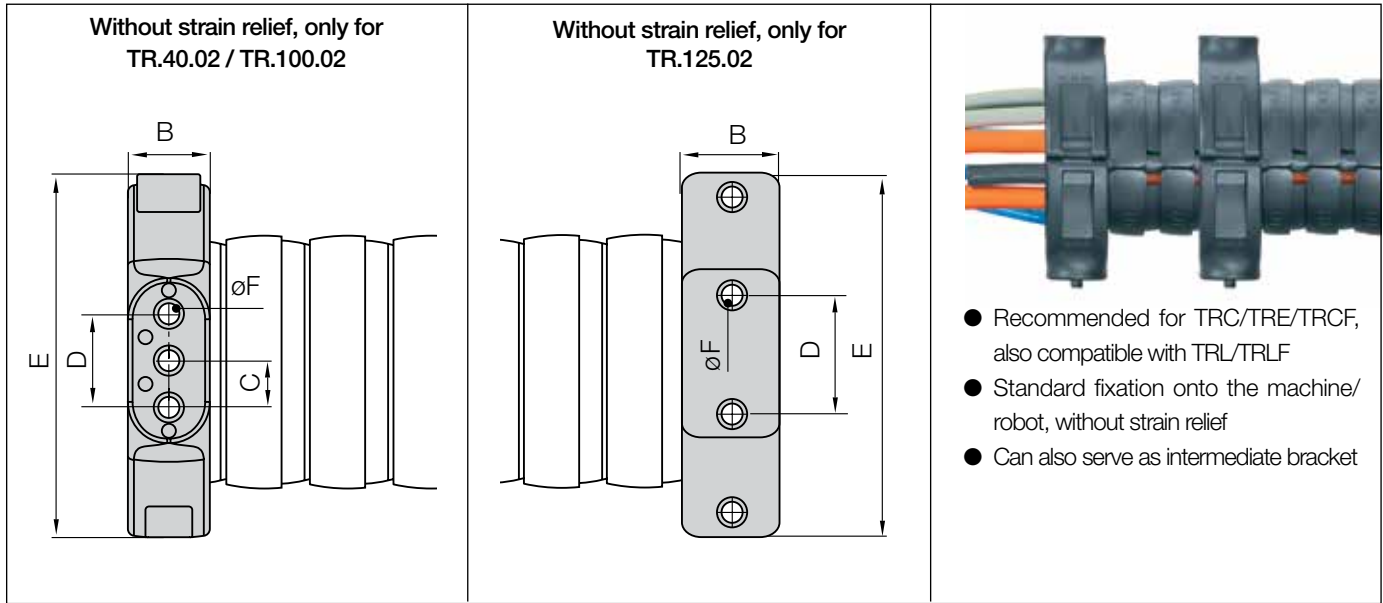

- Recommended for TRC/TRE/TRCF, also compatible with TRL/TRLF
- Standard fixation onto the machine/robot, without strain relief
- Can also serve as intermediate bracket

Standard mounting brackets - Without strain relief



TR.40.02 – TR.100.02



TR.125.02

Ø Index	Part No. without strain relief or as intermediate bracket	A		B		C		D		E		F	
		in.	(mm)	in.	(mm)	in.	(mm)	in.	(mm)	in.	(mm)	in.	(mm)
30.	▶ Alternative: light mounting bracket	-	-	-	-	-	-	-	-	-	-	-	-
40.	▶ TR.40.02.M6 ¹⁾	-	.83 (21)	.53 (13.5)	1.06 (27)	3.33 (84.5)	.26 (6.5)						
50.	▶ TR.50.02.M6 ¹⁾	-	.83 (21)	.53 (13.5)	1.06 (27)	3.33 (84.5)	.26 (6.5)						
60.	▶ TR.60.02.M8 ¹⁾	-	1.26 (32)	.79 (20)	1.57 (40)	4.96 (126)	.35 (9)						
65.	▶ TR.65.02.M8 ¹⁾	-	1.26 (32)	.79 (20)	1.57 (40)	4.96 (126)	.35 (9)						
70.	▶ TR.70.02.M8 ¹⁾	-	1.26 (32)	.79 (20)	1.57 (40)	4.96 (126)	.35 (9)						
85.	▶ TR.85.02.M8 ¹⁾	-	1.38 (35)	.79 (20)	1.57 (40)	6.10 (155)	.35 (9)						
85. (R 240)	▶ TR.85.240.02.M8 ¹⁾	-	1.38 (35)	.79 (20)	1.57 (40)	6.10 (155)	.35 (9)						
100.	▶ TR.100.02.M8 ¹⁾	-	1.38 (35)	.79 (20)	1.57 (40)	6.10 (155)	.35 (9)						
125.	▶ Alternative: standard mounting bracket without strain relief												

Standard: through holes in Ø F - 1) option: with threaded bushings, steel, M6/M8
 2) ⚠ Available as ESD version from stock

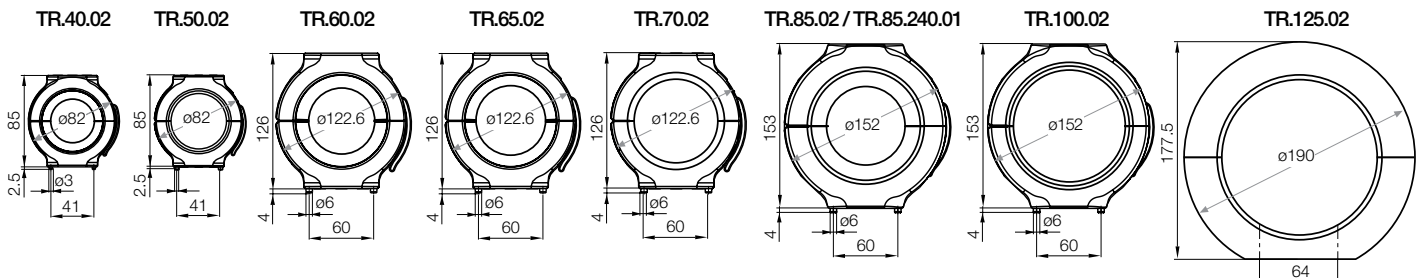

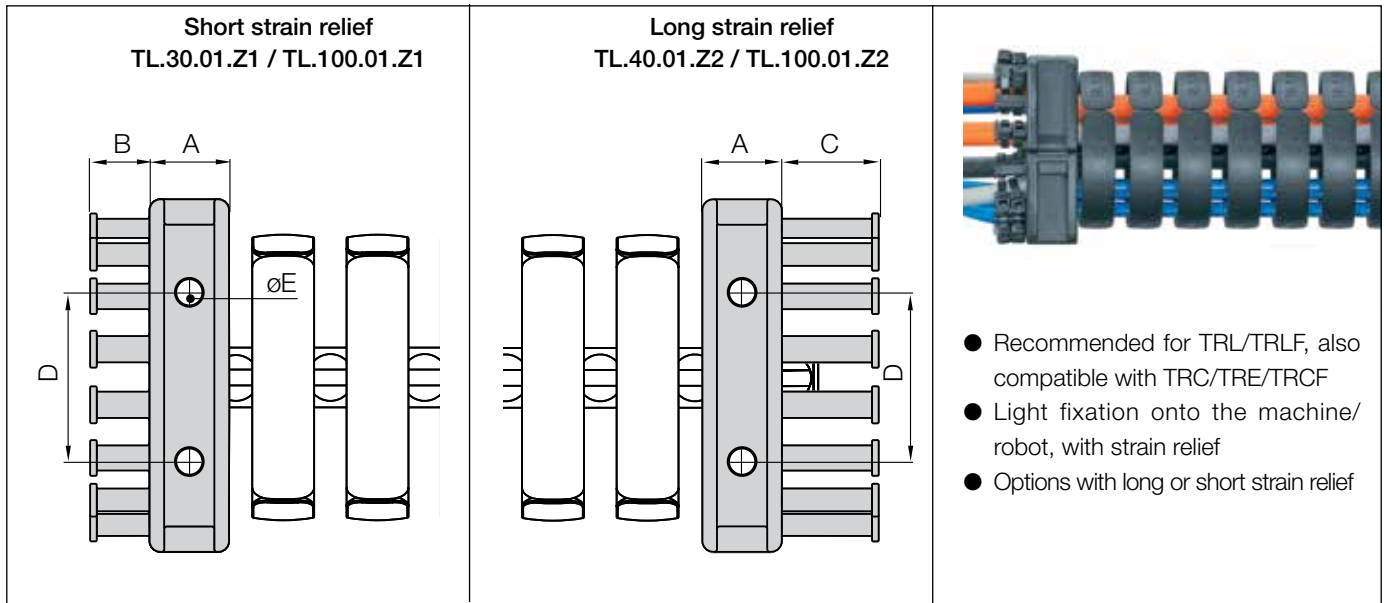

- Recommended for TRL/TRLF, also compatible with TRC/TRE/TRCF
- Light fixation onto the machine/robot, with strain relief
- Options with long or short strain relief

Light mounting brackets - With strain relief



TL.30.01.Z1 to TL.100.01.Z1



TL.40.01.Z2 to TL.100.01.Z2

Index	Part No. with short strain relief	Part No. with long strain relief	A		B		C		D		E	
			in.	(mm)	in.	(mm)	in.	(mm)	in.	(mm)	in.	(mm)
30.	▶ TL.30.01.Z1	-	.51	(13)	.49	(12.5)	-	-	.94	(24)	.18	4.5
40.	▶ TL.40.01.Z1 ¹⁾	TL.40.01.Z2	.55	(14)	.49	(12.5)	.79	(20)	1.42	(36)	.23	(5.8)
50.	▶ Alternative: standard mounting bracket		-	-	-	-	-	-	-	-	-	-
60.	▶ TL.60.01.Z1 ¹⁾	TL.60.01.Z2	.79	(20)	.67	(17)	1.06	(27)	1.89	(48)	.23	(5.8)
65.	▶ TL.65.01.Z1 ¹⁾	-	1.06	(27)	.53	(13.5)	-	-	2.52	(64)	.26	(6.5)
70.	▶ TL.70.01.Z1 ¹⁾	TL.70.01.Z2	1.06	(27)	.69	(17.5)	1.08	(27.5)	2.52	(64)	.26	(6.5)
85.	▶ TL.85.01.Z1	-	1.18	(30)	1.04	(26.5)	-	-	2.52	(64)	.26	(6.5)
85. (R 240)	▶ Alternative: standard mounting bracket		-	-	-	-	-	-	-	-	-	-
100.	▶ TL.100.01.Z ¹⁾	TL.100.01.Z2	1.18	(30)	.88	(22.5)	1.67	(42.5)	2.52	(64)	.26	(6.5)
125.	▶ Alternative: standard mounting bracket		-	-	-	-	-	-	-	-	-	-

1) For moving end (ball) suitable only for series TRL/TRLF

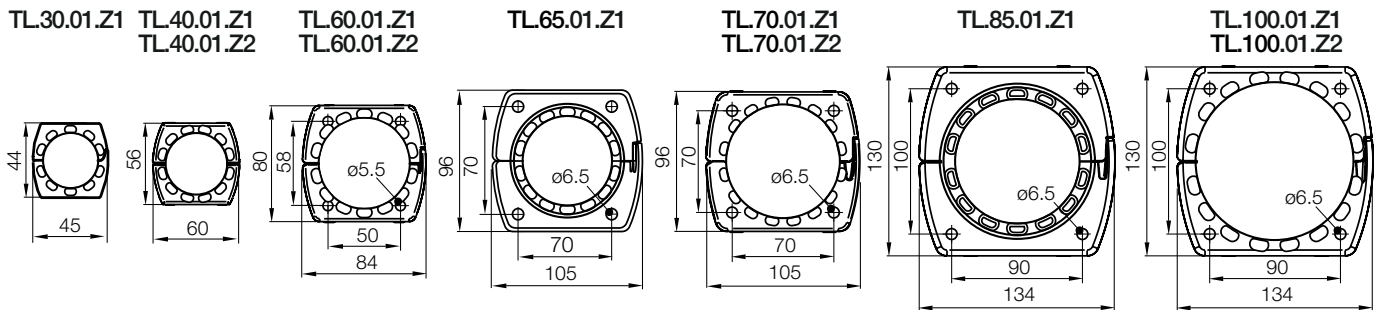

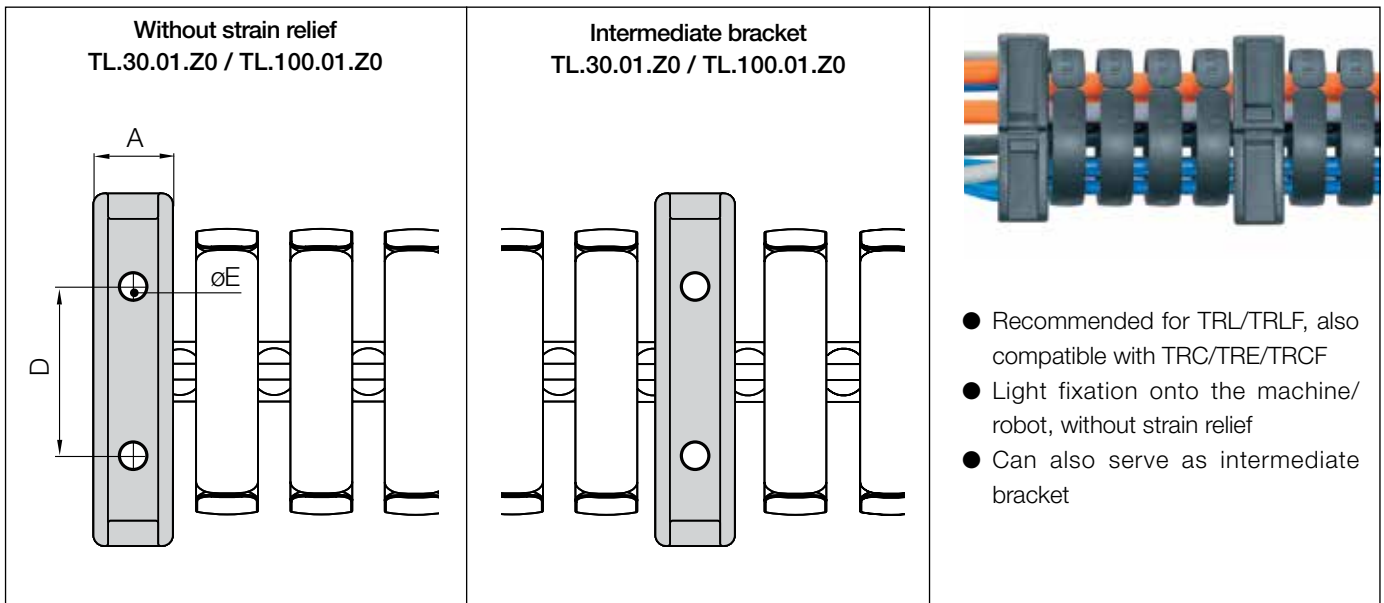

- Recommended for TRL/TRLF, also compatible with TRC/TRE/TRCF
- Light fixation onto the machine/robot, without strain relief
- Can also serve as intermediate bracket

Light mounting brackets - Without strain relief



TL.30.01.Z0 to TL.100.01.Z0

ø Index	Part No. without strain relief or as intermediate bracket	A		B		C		D		E	
		in.	(mm)	in.	(mm)	in.	(mm)	in.	(mm)	in.	(mm)
30.	▶ TL.30.01.Z0	.51	(13)	-	-	-	-	.94	(24)	.18	4.5
40.	▶ TL.40.01.Z0	.55	(14)	-	-	-	-	1.42	(36)	.23	(5.8)
60.	▶ TL.60.01.Z0	.79	(20)	-	-	-	-	1.89	(48)	.23	(5.8)
65.	▶ TL.65.01.Z0	1.06	(27)	-	-	-	-	2.52	(64)	.26	(6.5)
70.	▶ TL.70.01.Z0	1.06	(27)	-	-	-	-	2.52	(64)	.26	(6.5)
85.	▶ TL.85.01.Z0	1.18	(30)	-	-	-	-	2.52	(64)	.26	(6.5)
85. (R 240)	▶ TL.85.240.01.Z0	-	-	-	-	-	-	-	-	-	-
100.	▶ TL.100.01.Z0	1.18	(30)	-	-	-	-	2.52	(64)	.26	(6.5)
125.	▶ Alternative: standard mounting bracket	-	-	-	-	-	-	-	-	-	-

TL.30.01.Z0 TL.40.01.Z0 TL.60.01.Z0 TL.65.01.Z0 TL.70.01.Z0 TL.85.01.Z0 TL.100.01.Z0

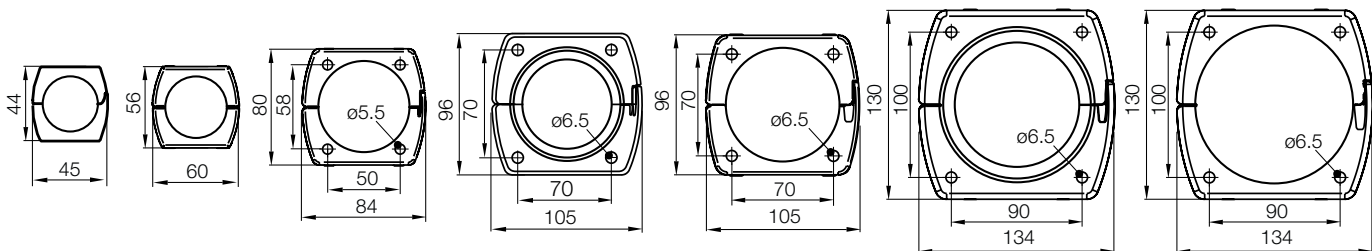

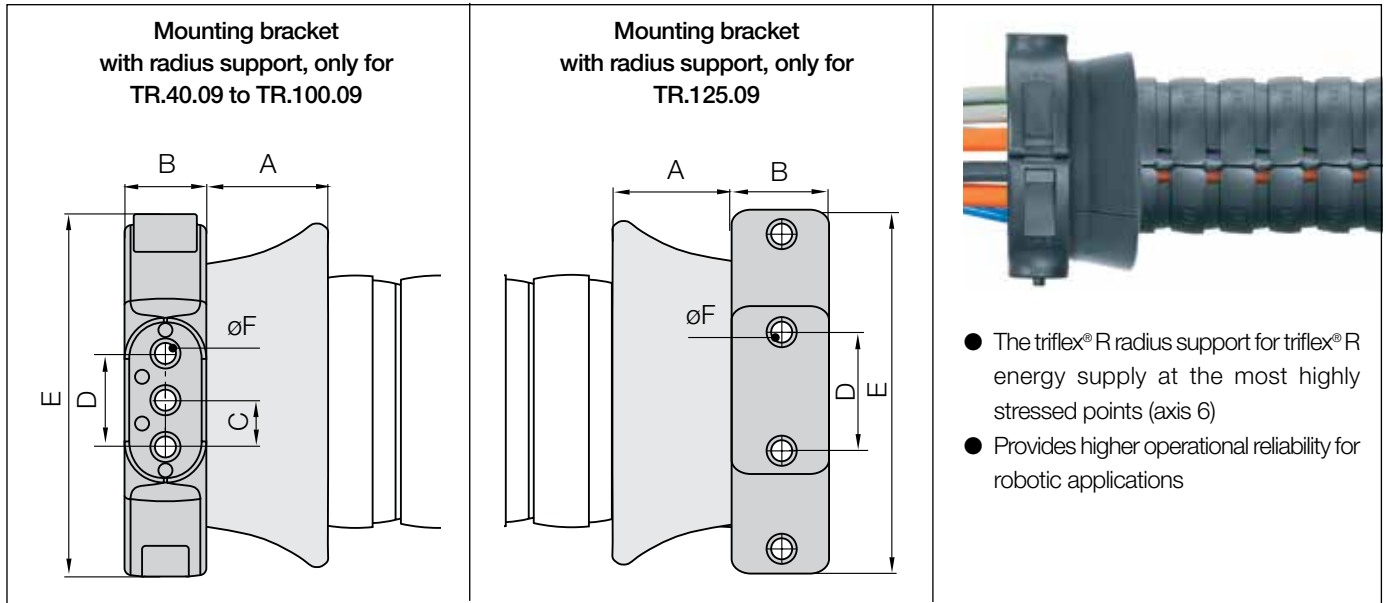

- The triflex® R radius support for triflex® R energy supply at the most highly stressed points (axis 6)
- Provides higher operational reliability for robotic applications

Mounting brackets - With radius support - For TRC·TRE·TRCF·TRL·TRLF



TR.40.09 to TR.100.09



TR.125.09

ø Index	Part No. with short strain relief	A		B		C		D		E		F	
		in.	(mm)	in.	(mm)	in.	(mm)	in.	(mm)	in.	(mm)	in.	(mm)
30.	▶ -	-	-	-	-	-	-	-	-	-	-	-	-
40.	▶ TR.40.09.M6 ¹⁾	1.10	(28)	.83	(21)	.53	(13.5)	1.06	(27)	3.33	(84.5)	.26	(6.5)
50.	▶ TR.50.09.M6 ¹⁾	1.50	(38)	.83	(21)	.53	(13.5)	1.06	(27)	3.33	(84.5)	.26	(6.5)
60.	▶ TR.60.09.M8 ¹⁾	1.50	(38)	1.26	(32)	.79	(20)	1.57	(40)	4.96	(126)	.35	(9)
65.	▶ TR.65.09.M8 ¹⁾	1.77	(45)	1.26	(32)	.79	(20)	1.57	(40)	4.96	(126)	.35	(9)
70.	▶ TR.70.09.M8 ¹⁾	1.69	(43)	1.26	(32)	.79	(20)	1.57	(40)	4.96	(126)	.35	(9)
85.	▶ TR.85.09.M8 ¹⁾	1.93	(49)	1.38	(35)	.79	(20)	1.57	(40)	6.10	(155)	.35	(9)
85. (R 240)	▶ -	-	-	-	-	-	-	-	-	-	-	-	-
100.	▶ TR.100.09.M8 ¹⁾	2.64	(67)	1.38	(35)	.79	(20)	1.57	(40)	6.10	(155)	.35	(9)
125.	▶ TR.125.09.M8 ¹⁾	2.83	(72)	1.57	(40)	-	-	2.52	(64)	7.48	(190)	.35	(9)

Standard: through holes in Ø F - 1) option: with threaded bushings, steel, M6/M8

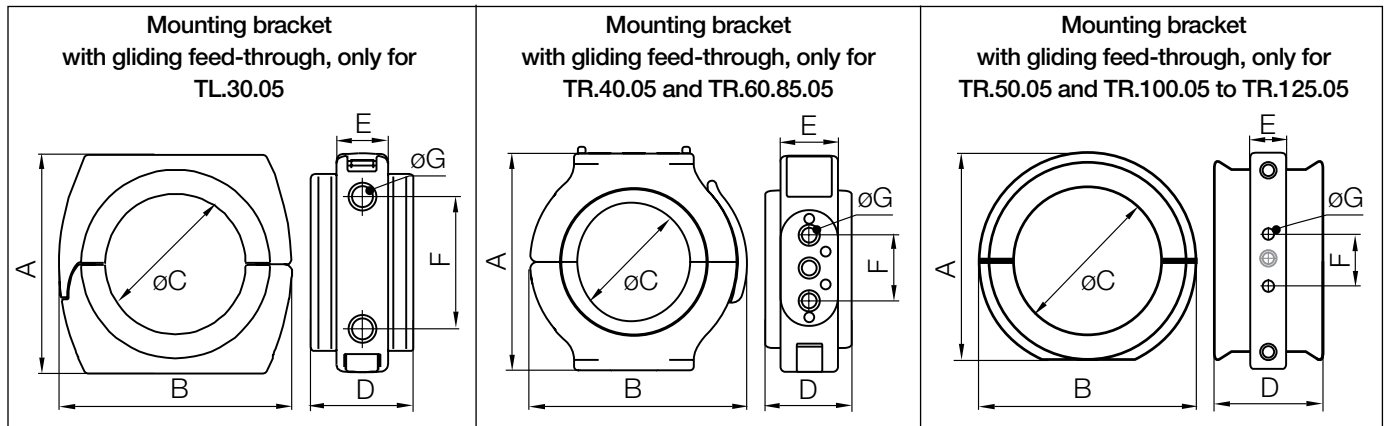

- The gliding feed-through enables easy guidance of the e-chain® and can also be used as an additional guide
- Gliding feed-through with swivel bearing also available



Gliding feed-through - For TRC·TRE·TRCF·TRL·TRLF



TL.30.05



TR.40.05 and TR.60.05 to TR.85.05



TR.50.05 and TR.100.05 to TR.125.05

Index	Part No. with short strain relief	A		B		C		D		E		F		G	
		in.	(mm)	in.	(mm)	in.	(mm)	in.	(mm)	in.	(mm)	in.	(mm)	in.	(mm)
30.	▶ TL.30.05	2.20	(56)	2.36	(60)	1.42	(36)	1.10	(28)	.55	(14)	1.42	(36)	.23	(5.8)
40.	▶ TR.40.05.M6 ¹⁾	3.35	(85)	3.33	(84.5)	1.81	(46)	1.26	(32)	.83	(21)	1.06	(27)	.26	(6.5)
50.	▶ TR.50.05.M6 ¹⁾	3.78	(96)	4.02	(102)	2.28	(58)	2.64	(67)	.83	(21)	1.06	(27)	.26	(6.5)
60.	▶ TR.60.05.M8 ¹⁾	4.96	(126)	4.96	(126)	2.76	(70)	1.97	(50)	1.26	(32)	1.57	(40)	.35	(9)
65. (R 200)	▶ TR.65.05.M8 ¹⁾	4.96	(126)	4.96	(126)	2.95	(75)	2.95	(75)	1.26	(32)	1.57	(40)	.35	(9)
70.	▶ TR.70.05.M8 ¹⁾	6.02	(153)	6.10	(155)	3.39	(86)	2.76	(70)	1.38	(35)	1.57	(40)	.35	(9)
85.	▶ TR.85.05.M8 ¹⁾	6.02	(153)	6.10	(155)	3.94	(100)	3.31	(84)	1.38	(35)	1.57	(40)	.35	(9)
85. (R 240)	▶ TR.85.05.M8 ¹⁾	6.02	(153)	6.10	(155)	3.94	(100)	3.31	(84)	1.38	(35)	1.57	(40)	.35	(9)
100.	▶ TR.100.05.M8 ¹⁾ *	6.40	(162.5)	6.67	(169.5)	4.53	(115)	3.35	(85)	1.10	(28)	1.57	(40)	.33	(8.5)
125.	▶ TR.125.05.M8 ¹⁾	7.05	(179)	7.48	(190)	5.59	(142)	3.31	(84)	1.57	(40)	2.52	(64)	.35	(9)

TR.100.05 with 3 holes

Standard: through holes in Ø G

1) option: with insert nuts, steel, M6/M8

Mounting bracket
with strain relief, only for TR.40.03 to TR.100.03

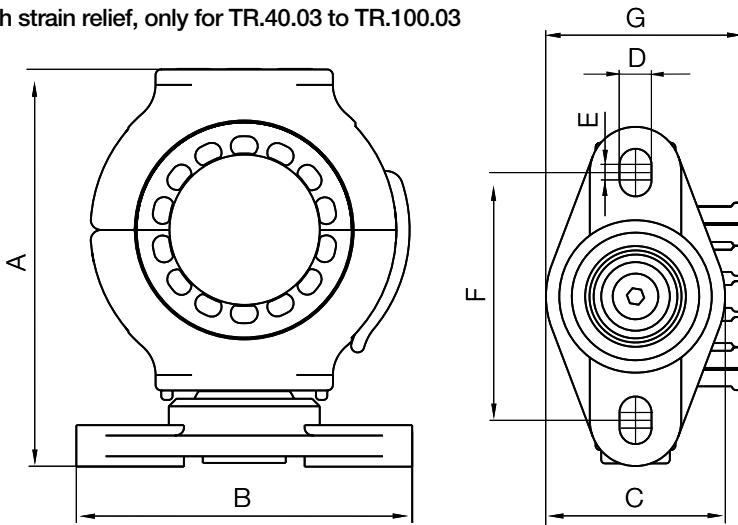

- Standard mounting bracket with strain relief and maintenance-free igubal® spherical bearing
- Pivoting mounting for extreme rotating and reverse bending movements
- For TRC·TRE·TRCF·TRL·TRLF

Swivel bearing mounting brackets - With strain relief - For TRC·TRE·TRCF·TRL·TRLF



TR.40.03 /
TR.100.03

ø Index	Part No. with strain relief	A		B		C		D		E		F		G	
		in.	(mm)	in.	(mm)	in.	(mm)	in.	(mm)	in.	(mm)	in.	(mm)	in.	(mm)
30.	▶	-		-		-		-		-		-		-	
40.	▶ TR.40.03	4.13	(105)	3.50	(89)	1.85	(47)	.33	(8.4)	.16	(4.1)	2.56	(65)	2.04	(51.8)
50.	▶ TR.50.03	4.13	(105)	3.50	(89)	1.85	(47)	.33	(8.4)	.16	(4.1)	2.56	(65)	2.17	(55)
60.	▶ TR.60.03	5.98	(152)	4.65	(118)	2.56	(65)	.41	(10.5)	.22	(5.5)	3.44	(87.5)	2.89	(73.5)
65.	▶ TR.65.03	5.98	(152)	4.65	(118)	2.56	(65)	.41	(10.5)	.22	(5.5)	3.44	(87.5)	2.89	(73.5)
70.	▶ TR.70.03	5.98	(152)	4.65	(118)	2.56	(65)	.41	(10.5)	.22	(5.5)	3.44	(87.5)	2.89	(73.5)
85.	▶ TR.85.03	7.05	(179)	4.65	(118)	2.56	(65)	.41	(10.5)	.22	(5.5)	3.44	(87.5)	3.46	(88)
85. (R 240)	▶ TR.85.240.03	7.05	(179)	4.65	(118)	2.56	(65)	.41	(10.5)	.22	(5.5)	3.44	(87.5)	3.46	(88)
100.	▶ TR.100.03	7.05	(179)	4.65	(118)	2.56	(65)	.41	(10.5)	.22	(5.5)	3.44	(87.5)	3.46	(88)
125.	▶	-		-		-		-		-		-		-	

Mounting bracket
 without strain relief, only for TR.40.04 to TR.100.04

- Standard mounting bracket without strain relief and maintenance-free igubal® spherical bearing
- Pivoting mounting for extreme rotating and reverse bending movements
- For TRC·TRE·TRCF·TRL·TRLF

Swivel bearing mounting brackets - Without strain relief - For TRC·TRE·TRCF·TRL·TRLF



**TR.40.04 /
TR.100.04**

ø Index	Part No. without strain relief	A		B		C		D		E		F		G	
		in.	(mm)	in.	(mm)	in.	(mm)	in.	(mm)	in.	(mm)	in.	(mm)	in.	(mm)
30.	▶	-		-		-		-		-		-		-	
40.	▶ TR.40.04	4.13	(105)	3.50	(89)	1.85	(47)	.33	(8.4)	.16	(4.1)	2.56	(65)	-	
50.	▶ TR.50.04	4.13	(105)	3.50	(89)	1.85	(47)	.33	(8.4)	.16	(4.1)	2.56	(65)	-	
60.	▶ TR.60.04	5.98	(152)	4.65	(118)	2.56	(65)	.41	(10.5)	.22	(5.5)	3.44	(87.5)	-	
65.	▶ TR.65.04	5.98	(152)	4.65	(118)	2.56	(65)	.41	(10.5)	.22	(5.5)	3.44	(87.5)	-	
70.	▶ TR.70.04	5.98	(152)	4.65	(118)	2.56	(65)	.41	(10.5)	.22	(5.5)	3.44	(87.5)	-	
85.	▶ TR.85.04	7.05	(179)	4.65	(118)	2.56	(65)	.41	(10.5)	.22	(5.5)	3.44	(87.5)	-	
85. (R 240)	▶ TR.85.240.04	7.05	(179)	4.65	(118)	2.56	(65)	.41	(10.5)	.22	(5.5)	3.44	(87.5)	-	
100.	▶ TR.100.04	7.05	(179)	4.65	(118)	2.56	(65)	.41	(10.5)	.22	(5.5)	3.44	(87.5)	-	
125.	▶	-		-		-		-		-		-		-	

Swivel bearing gliding feed-throughs
TR.40.07 to TR.85.07

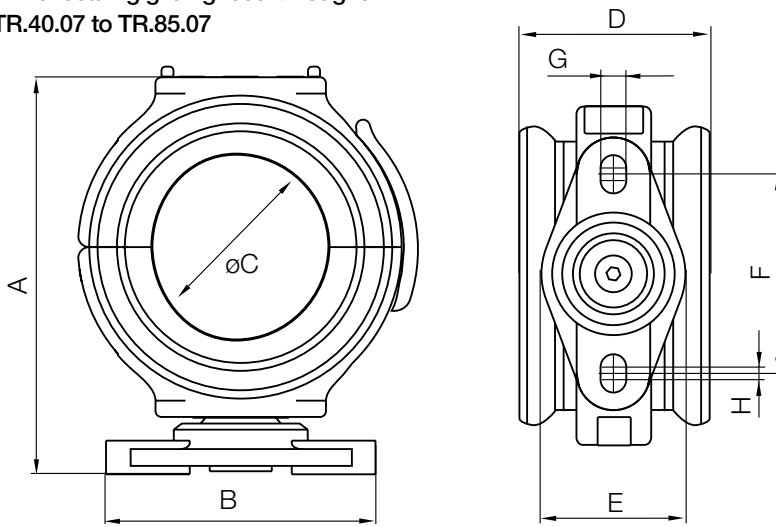

- Gliding feed-through with swivel bearing
- For TRC·TRE·TRCF e-chains®
- Pivoting mounting with maintenance-free igubal® spherical bearings

Swivel bearing gliding feed-throughs - For TRC·TRE·TRCF



TR.40.07 to
TR.100.07

Ø Index	Part No. with swivel bearing	A		B		C		D		E		F		G	
		in.	(mm)	in.	(mm)	in.	(mm)	in.	(mm)	in.	(mm)	in.	(mm)	in.	(mm)
30.	▶	-	-	-	-	-	-	-	-	-	-	-	-	-	-
40.	▶ TR.40.07	4.25	(108)	3.50	(89)	1.81	(46)	1.26	(32)	1.85	(47)	2.56	(65)	.33	(8.4)
50.	▶ TR.50.07	4.69	(119)	3.50	(89)	2.28	(58)	2.64	(67)	1.85	(47)	2.56	(65)	.33	(8.4)
60.	▶ TR.60.07	6.14	(156)	4.65	(118)	2.76	(70)	1.97	(50)	2.56	(65)	3.44	(87.5)	.41	(10.5)
60.	▶ TR.65.07	6.14	(156)	4.65	(118)	2.95	(75)	2.95	(75)	2.56	(65)	3.44	(87.5)	.41	(10.5)
70.	▶ TR.70.07	7.20	(183)	4.65	(118)	3.39	(86)	2.76	(70)	2.56	(65)	3.44	(87.5)	.41	(10.5)
85.	▶ TR.85.07	7.20	(183)	4.65	(118)	3.94	(100)	3.31	(84)	2.56	(65)	3.44	(87.5)	.41	(10.5)
85.	(R 240) ▶ TR.85.07	7.20	(183)	4.65	(118)	3.94	(100)	3.31	(84)	2.56	(65)	3.44	(87.5)	.41	(10.5)
100.	▶ -	-	-	-	-	-	-	-	-	-	-	-	-	-	-
125.	▶ -	-	-	-	-	-	-	-	-	-	-	-	-	-	-

Protector
TR.XX.10 to TR.XX.30

- Optional protectors can be fitted at contact points
- For extreme operations and long service life
- Easy gliding over edges
- Damping, light, freely positionable
- Easy to fit and quick replacement
- Protector with quick-release fastener also available

Protectors - For TRC·TRE·TRCF



TR.40.10 to
TR.125.10



TR.40.30 to
TR.100.30

\varnothing Index	Part No. with screw connection	Part No. with quick release	A in. (mm)	B in. (mm)
30.	▶	-	-	-
40.	▶ TR.40.10	TR.40.30 ²⁾	1.06 (27)	2.17 (55)
50.	▶ TR.50.10	TR.50.30 ¹⁾	1.34 (34)	2.72 (69)
60.	▶ TR.60.10	TR.60.30 ²⁾	1.57 (40)	3.15 (80)
65.	▶ TR.65.10	TR.65.30 ¹⁾	1.73 (44)	3.46 (88)
70.	▶ TR.70.10	TR.70.30	1.97 (50)	4.02 (102)
85.	▶ TR.85.10	TR.85.30	2.32 (59)	4.65 (118)
85. (R 240)	▶ TR.85.240.10	TR.85.240.30 ¹⁾	2.48 (63)	4.72 (120)
100.	▶ TR.100.10	TR.100.30	2.64 (67)	5.24 (133)
125.	▶ TR.125.10	-	3.23 (82)	6.69 (170)

1) Available upon request. Delivery time upon request
2) TR-40-30, TR-60-30 without an additional locking clip

Heavy duty connections - Standard
TR.60.20.XX to TR.125.20.XX

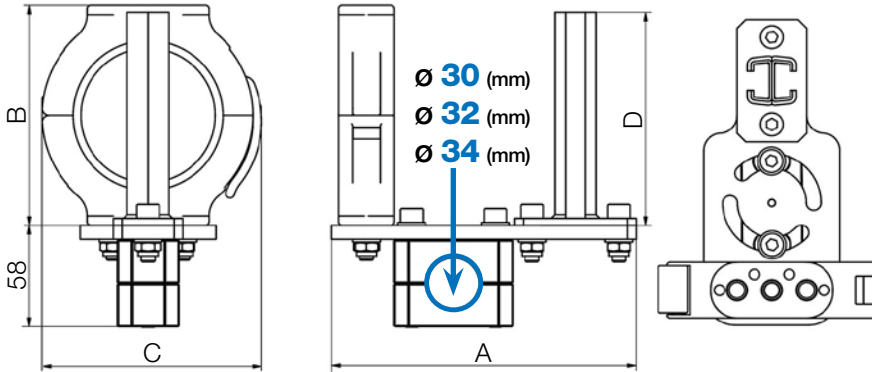

- Heavy duty connection - standard
- For cables with large cross section
- For heavy hydraulic hoses
- Double C-profile for CFX clamps
- igus® chainfix clamps must be ordered separately

Heavy duty connections - For TRC·TRE·TRCF

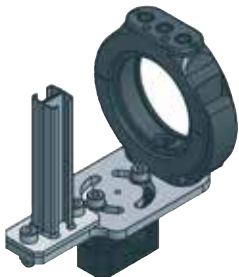

TR.60.20.XX to
TR.125.20.XX

Ø Index	Part No. standard	Clamp diameter Ø (mm)	A		B		C		D	
			in.	(mm)	in.	(mm)	in.	(mm)	in.	(mm)
30.	▶ -	-	-	-	-	-	-	-	-	-
40.	▶ -	-	-	-	-	-	-	-	-	-
50.	▶ -	-	-	-	-	-	-	-	-	-
60.	▶ TR.60.20.	30 32 34	6.89	(175)	4.96	(126)	4.96	(126)	4.80	(122)
65.	▶ TR.65.20.	30 32 34	6.89	(175)	4.96	(126)	4.96	(126)	4.80	(122)
70.	▶ TR.70.20.	30 32 34	6.89	(175)	4.96	(126)	4.96	(126)	4.80	(122)
85.	▶ TR.85.20.	30 32 34	6.89	(175)	6.02	(153)	6.10	(155)	5.87	(149)
85. (R 240)	▶ TR.85.240.20.	30 32 34	6.89	(175)	6.02	(153)	6.10	(155)	5.87	(149)
100.	▶ TR.100.20.	30 32 34	6.89	(175)	6.02	(153)	6.10	(155)	5.87	(149)
125.	▶ TR.125.20.	30 32 34	7.09	(180)	7.48	(190)	7.48	(190)	6.89	(175)

Standard clamp for axis 6: Ø (30mm) 1.18"

Part No. with desired diameter for the axis 6 clamp | 30 | 32 | 34 | e.g. TR.100.20.30

Heavy duty connections - With radius support
 TR.60.23.XX to TR.125.23.XX

- With radius support
- For cables with large cross section
- For heavy hydraulic hoses
- Double C-profile for CFX clamps
- igus® chainfix clamps must be ordered separately. Protector with quick-release fastener also available

Heavy duty connections - With radius support - For TRC·TRE·TRCF

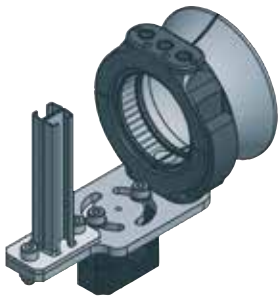

TR.60.23.XX to
TR.125.23.XX

Ø Index	Part No. with radius support	Clamp diameter Ø (mm)	A		B		C		D		E	
			in.	(mm)	in.	(mm)	in.	(mm)	in.	(mm)	in.	(mm)
30.	▶ -	-	-	-	-	-	-	-	-	-	-	-
40.	▶ -	-	-	-	-	-	-	-	-	-	-	-
50.	▶ -	-	-	-	-	-	-	-	-	-	-	-
60.	▶ TR.60.23.	30 32 34	8.23	(209)	4.96	(126)	5.12	(130)	4.80	(122)	1.50	(38)
65.	▶ TR.65.23.	30 32 34	8.43	(214)	4.96	(126)	5.12	(130)	4.80	(122)	1.77	(45)
70.	▶ TR.70.23.	30 32 34	8.43	(214)	4.96	(126)	5.12	(130)	4.80	(122)	1.69	(43)
85.	▶ TR.85.23.	30 32 34	8.74	(222)	6.10	(155)	6.10	(155)	5.87	(149)	1.93	(49)
85. (R 240)	▶ -	-	-	-	-	-	-	-	-	-	-	-
100.	▶ TR.100.23.	30 32 34	9.45	(240)	6.10	(155)	6.10	(155)	5.87	(149)	2.64	(67)
125.	▶ TR.125.23.	30 32 34	9.92	(252)	7.48	(190)	7.48	(190)	6.89	(175)	2.83	(72)

Standard clamp for axis 6: Ø (30mm) 1.18"

Part No. with desired diameter for the axis 6 clamp | 30 | 32 | 34 | e.g. TR.100.20.30

Compact connection - **With strain relief**
TR.40.21.01.XX to TR.100.21.01.XX

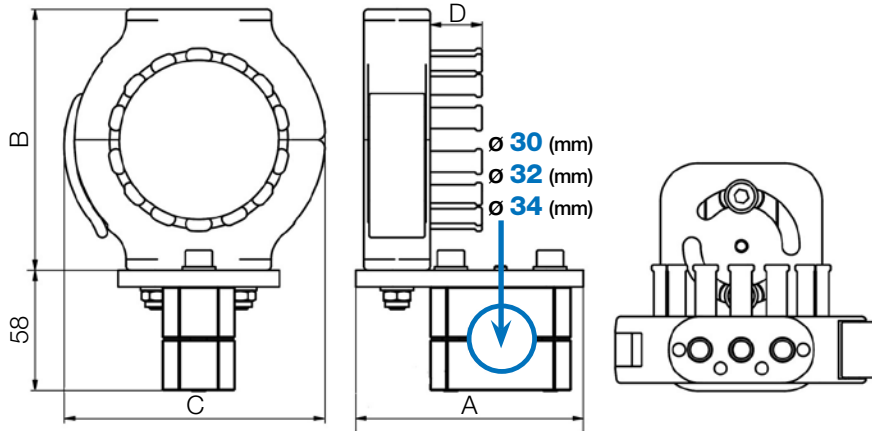

- With integrated strain relief tiwrap plates
- Safe and simple securing of the cables with cable ties
- Various adjustment options

Compact connections - With strain relief - For TRC-TRE-TRCF



TR.40.21.01.XX to
TR.100.21.01.XX

Ø Index	Part No. with strain relief	Clamp diameter Ø (mm)	A		B		C		D	
			in.	(mm)	in.	(mm)	in.	(mm)	in.	(mm)
30.	▶ -	-	-	-	-	-	-	-	-	-
40.	▶ TR.40.21.01.	30 32 34	4.33	(110)	3.35	(85)	3.33	(84.5)	.70	(17.8)
50.	▶ TR.50.21.01.	30 32 34	4.33	(110)	3.35	(85)	3.33	(84.5)	.83	(21)
60.	▶ TR.60.21.01.	30 32 34	4.33	(110)	4.96	(126)	4.96	(126)	.98	(25)
70.	▶ TR.70.21.01.	30 32 34	4.33	(110)	4.96	(126)	4.96	(126)	.98	(25)
85.	▶ TR.85.21.01.	30 32 34	4.33	(110)	6.02	(153)	6.10	(155)	1.50	(38)
85. (R 240)	▶ TR.85.240.21.01.	30 32 34	4.33	(110)	6.02	(153)	6.10	(155)	1.50	(38)
100.	▶ TR.100.21.01.	30 32 34	4.33	(110)	6.02	(153)	6.10	(155)	1.50	(38)
125.	▶ -	-	-	-	-	-	-	-	-	-

Standard clamp for axis 6: Ø (30mm) 1.18"

Part No. with desired diameter for the axis 6 clamp | 30 | 32 | 34 | e.g. TR.100.21.30

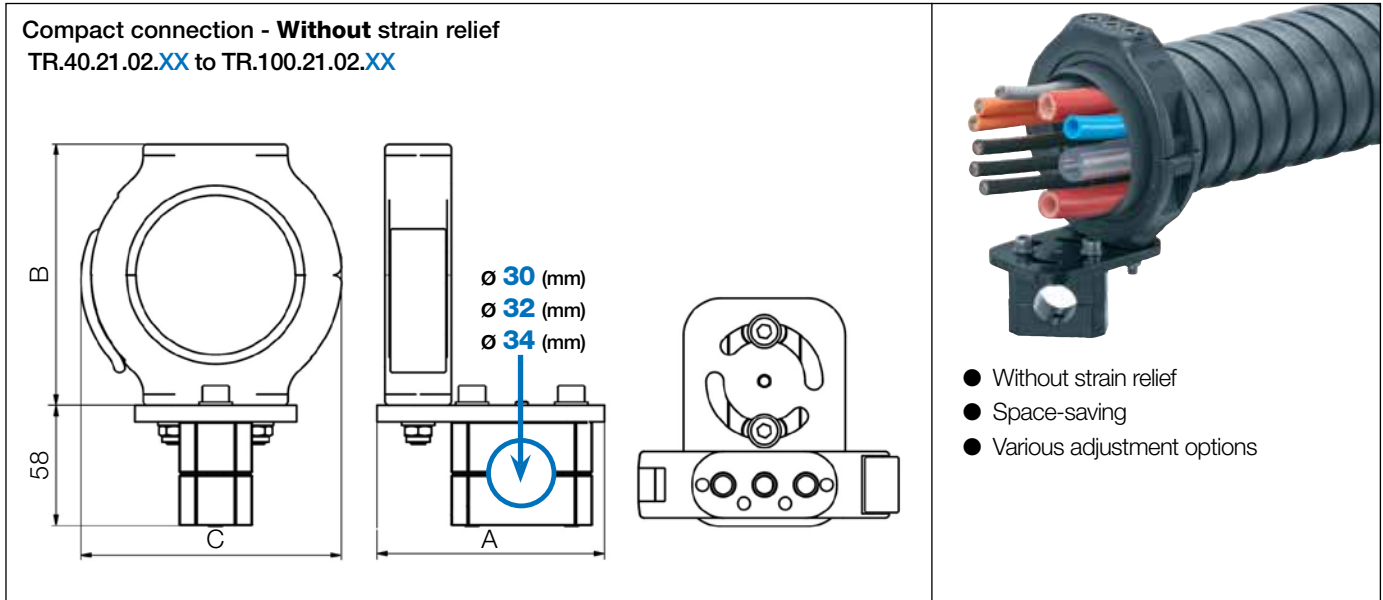

Compact connections - Without strain relief - For TRC-TRE-TRCF



TR.40.21.02.XX to
TR.100.21.02.XX

Ø Index	Part No. without strain relief	Clamp diameter Ø (mm)	A in. (mm)	B in. (mm)	C in. (mm)
30.	▶ -	-	-	-	-
40.	▶ TR.40.21.02.	30 32 34	4.33 (110)	3.35 (85)	3.33 (84.5)
50.	▶ TR.50.21.02.	30 32 34	4.33 (110)	3.35 (85)	3.33 (84.5)
60.	▶ TR.60.21.02.	30 32 34	4.33 (110)	4.96 (126)	4.96 (126)
65.	▶ TR.65.21.02.	30 32 34	4.33 (110)	4.96 (126)	4.96 (126)
70.	▶ TR.70.21.02.	30 32 34	4.33 (110)	6.02 (153)	6.10 (155)
85.	▶ TR.85.21.02.	30 32 34	4.33 (110)	6.02 (153)	6.10 (155)
85. (R 240)	▶ TR.85.240.21.02.	30 32 34	4.33 (110)	6.02 (153)	6.10 (155)
100.	▶ TR.100.21.02.	30 32 34	9.45 (240)	6.10 (155)	6.10 (155)
125.	▶ -	-	-	-	-

Standard clamp for axis 6: Ø (30mm) 1.18"

Part No. with desired diameter for the axis 6 clamp | 30 | 32 | 34 | e.g. TR.100.21.02.30

Quick exchange kit
TR.60.22.XX to TR.100.22.XX

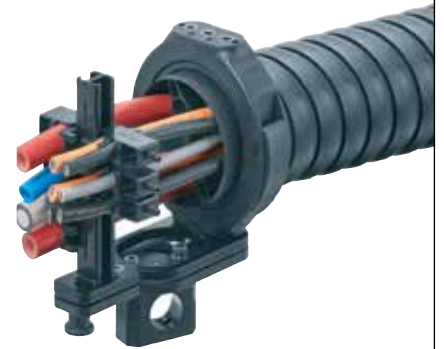
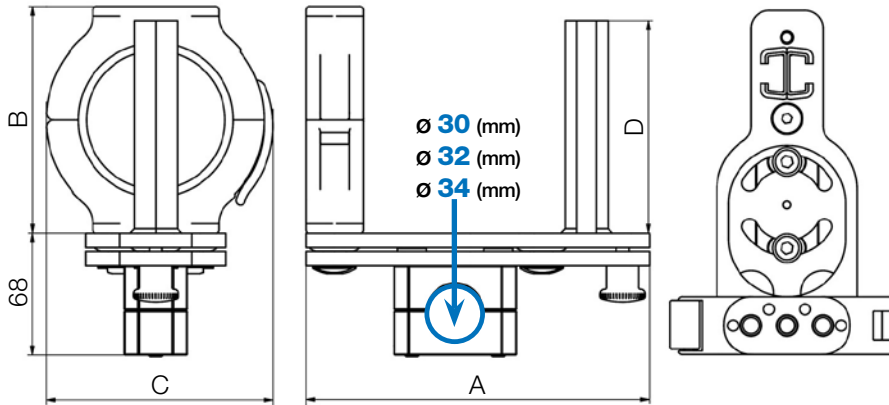

- Exchange in seconds
- No repeat alignment required
- Exchange the triflex® R unit incl. cables without tools
- Option available with strain relief

Quick exchange kit - For TRC-TRE-TRCF

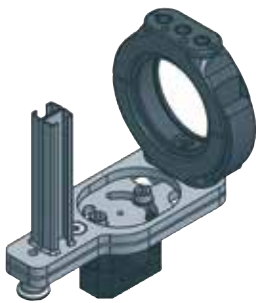

TR.60.22.XX to
TR.100.22.XX

Ø Index	Part No. quick change unit	Clamp diameter Ø (mm)	A		B		C		D	
			in.	(mm)	in.	(mm)	in.	(mm)	in.	(mm)
30.	▶ -	-	-	-	-	-	-	-	-	-
40.	▶ -	-	-	-	-	-	-	-	-	-
50.	▶ -	-	-	-	-	-	-	-	-	-
60.	▶ TR.60.22.	30 32 34	7.52	(191)	4.96	(126)	4.96	(126)	4.96	(126)
65.	▶ TR.65.22.	30 32 34	7.52	(191)	4.96	(126)	4.96	(126)	4.96	(126)
70.	▶ TR.70.22.	30 32 34	7.52	(191)	4.96	(126)	4.96	(126)	4.96	(126)
85.	▶ TR.85.22.	30 32 34	7.52	(191)	6.02	(153)	6.10	(155)	6.02	(153)
85. (R 240)	▶ TR.85.240.22.	30 32 34	7.52	(191)	6.02	(153)	6.10	(155)	6.02	(153)
100.	▶ TR.100.22.	30 32 34	7.52	(191)	6.02	(153)	6.10	(155)	6.02	(153)
125.	▶ -	-	-	-	-	-	-	-	-	-

Standard clamp for axis 6: \varnothing (30mm) 1.18"

Part No. with desired diameter for the axis 6 clamp | 30 | 32 | 34 | e.g. TR.100.22-30

chainfix - Single clamp including bottom saddles

- For use with heavy-duty connection
TR.XX.20 / TR.XX.23 and quick release unit **TR.XX.22**
- Reliably absorbs tensile forces even for larger cable diameters
- Specifically recommended for solid welding cables and rigid hydraulic hoses
- Space- and time-saving assembly onto the profile rail
- Simple assembly with hex head set screw
- High strength for dynamic applications with improved stacker elements
- Built-in ribs on the stacker elements give secure grip on the cables
- Steel (material galvanized steel) or stainless steel (material 1.4301/AISI 304) available



Part No. steel	Part No. stainless steel*	≤ Ø		B*2		H	
		in.	(mm)	in.	(mm)	in.	(mm)
CFX12-1	CFX12-1-E	.24 - .47	06 - 12	.63	16	1.57	40
CFX14-1	CFX14-1-E	.47 - .55	12 - 14	.71	18	1.97	50
CFX16-1	CFX16-1-E	.55 - .63	14 - 16	.79	20	2.05	52
CFX18-1	CFX18-1-E	.63 - .71	16 - 18	.87	22	2.13	54
CFX20-1	CFX20-1-E	.71 - .79	18 - 20	.94	24	2.20	56
CFX22-1	CFX22-1-E	.79 - .87	20 - 22	1.02	26	2.28	58
CFX26-1	CFX26-1-E	.87 - 1.02	22 - 26	1.18	30	2.64	67
CFX30-1	CFX30-1-E	1.02 - 1.18	26 - 30	1.34	34	2.80	71
CFX34-1	CFX34-1-E	1.18 - 1.34	30 - 34	1.50	38	2.95	75

*Stainless steel material: 1.4301/AISI 304

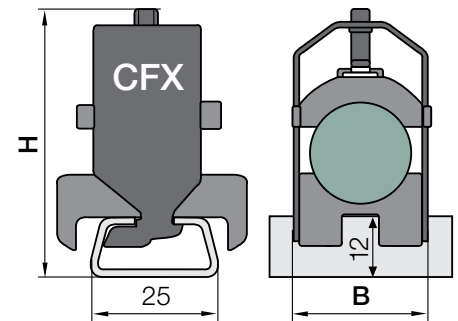

Individual strain relief for every cable offers security and easy replacement



Cable management systems for Cobots

Secure mounting brackets combined with superior triflex® cable management for all collaborative robots

Now, you can quickly attach or retrofit your cobot's cable management system in just a few simple steps using our plastic mounting brackets with hook and loop attachment straps. The adjustable straps fit around virtually any cobot manufacturer's arm. Each kit includes a length of triflex® R TRE cable carrier, designed for superior cable management and protection. The triflex® R TRE is designed with two easy access chambers to keep cables protected and features high tensile strength due to the ball-and-socket design. The triflex® R TRE has a small bend radius and short pitch as well as a defined torsion stop which allows for multi-axis movement in any direction.

Benefits:

- For various robot arm diameters, universal applications
- Compact, smooth design
- Silicone-free, suitable for the automotive industry
- Assembled and retrofitted in just a few steps
- Low-cost addition to cobot accessories product range



Cobot kit with hook and loop brackets



TR.COB.VEL.30 / TR.COB.VEL.40

Cost-effective mounting with hook-and-loop on both the robot and the cable carrier sides

Included in the kit:

- 1 triflex® cable carrier (approx. 6 ft.)
- 4 one-meter hook-and-loop lengths
- 4 Plastic bases
- 1 strain relief bracket
- 1 set of lock clips
- 1 set of screws
- 1 triflex® assembly tool



Cobot kit with light plastic brackets



TR.COB.LT.30 / TR.COB.LT.40

Lightweight plastic brackets for securing the cable carrier

Included in the kit:

- 1 triflex® cable carrier (approx. 6 ft.)
- 4 one-meter hook-and-loop lengths
- 4 Plastic bases
- 4 light brackets (screws included)
- 1 strain relief bracket
- 1 set of lock clips
- 1 triflex® assembly tool



Cobot kit with protected plastic brackets brackets



TR.COB.PRO.40



Plastic brackets with rounded edges for increased safety

Included in the kit:

- 1 triflex® cable carrier (approx. 6 ft.)
- 4 one-meter hook-and-loop lengths
- 4 Plastic bases
- 4 protector brackets (screws included)
- 1 strain relief bracket
- 1 set of lock clips
- 1 triflex® assembly tool



Cobot kit accessories

Part. No.	Description	Availability		
		30mm	40mm	50mm
TR.COB.01.00.0	 Plastic Base with hook and loop adjustable strap	●	●	●
TR.COB.LT.30	 Plastic Base with hook and loop adjustable strap and light mounting bracket	●	—	—
TR.COB.LT.40		—	●	—
TR.COB.PRO.40	 Plastic Base with hook and loop adjustable strap and protector bracket	—	●	—

Universal robot kits with metal clamp brackets

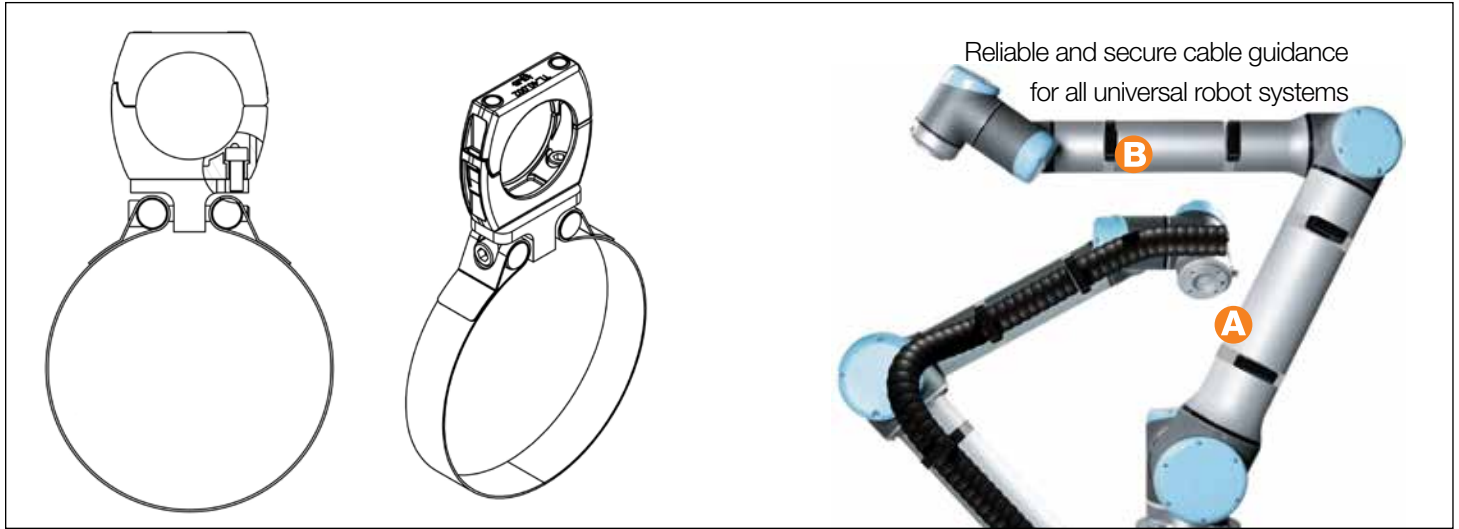

Universal Robot Kits using igus® metal brackets

igus part number	For UR-robot system	Triflex size
TR.UR3.TRE.30	UR3/UR3e	TRE.30
TR.UR3.TRE.40B	UR3/UR3e	TRE.40B
TR.UR3.TRC.30	UR3/UR3e	TRC.30
TR.UR3.TRC.40	UR3/UR3e	TRC.40
TR.UR5.TRE.30	UR5/UR5e	TRE.30
TR.UR5.TRE.40B	UR5/UR5e	TRE.40B

igus part number	For UR-robot system	Triflex size
TR.UR5.TRC.30	UR5/UR5e	TRC.30
TR.UR5.TRC.40	UR5/UR5e	TRC.40
TR.UR10.TRE.30	UR10/UR10e/UR16e	TRE.30
TR.UR10.TRE.40B	UR10/UR10e/UR16e	TRE.40B
TR.UR10.TRC.30	UR10/UR10e/UR16e	TRC.30
TR.UR10.TRC.40	UR10/UR10e/UR16e	TRC.40

Metal brackets - suitable for TRC-30 / TRE-30 / TRL-30 e-chains®

Part No. without strain relief	Part No. with strain relief	For UR-robot system	∅		Position
			in.	(mm)	
TR.911.965.054.Z0	TR.911.965.054.Z1	UR3/UR3e	2.13	(054)	B
TR.911.965.066.Z0	TR.911.965.066.Z1	UR3/UR3e	2.60	(066)	A
TR.911.965.075.Z0	TR.911.965.075.Z1	UR5/UR5e	2.95	(075)	B
TR.911.965.086.Z0	TR.911.965.086.Z1	UR5/UR5e	3.39	(086)	A
TR.911.965.086.Z0	TR.911.965.086.Z1	UR10/UR10e/UR16e	3.39	(086)	B
TR.911.965.108.Z0	TR.911.965.108.Z1	UR10/UR10e/UR16e	4.25	(108)	A

Metal brackets - suitable for TRC-40 / TRE-40 / TRL-40 e-chains®

Part No. without strain relief	Part No. with strain relief	For UR-robot system	∅		Position
			in.	(mm)	
TR.911.966.054.Z0	TR.911.966.054.Z1	UR3/UR3e	2.13	(054)	B
TR.911.966.066.Z0	TR.911.966.066.Z1	UR3/UR3e	2.60	(066)	A
TR.911.966.075.Z0	TR.911.966.075.Z1	UR5/UR5e	2.95	(075)	B
TR.911.966.086.Z0	TR.911.966.086.Z1	UR5/UR5e	3.39	(086)	A
TR.911.966.086.Z0	TR.911.966.086.Z1	UR10/UR10e/UR16e	3.39	(086)	B
TR.911.966.108.Z0	TR.911.966.108.Z1	UR10/UR10e/UR16e	4.25	(108)	A

Standard protective jacket



- Base support: fabric
- Plastic coated
- Easy to replace with Velcro fastenings
- Elastic sealing strips
- Standard lengths available from stock
- For paint or sealing applications
- PVC material
- Polyester coated fabrics

Heat shield protective jacket



- Made from heat resistant, wear-resistant Kevlar
- Short-term protection against welding and metal spatter, temperatures up to 540°C
 - High abrasion resistance
 - Sealed design
 - For tough environments
 - Easy to replace or retrofit with zipper closure
 - Velcro straps at each end
 - Tough design Silicone-free
 - Asbestos-free
- Standard lengths from stock

Wear resistant protective jacket



- Extremely high abrasion resistance
 - Black leather
 - For use in temperatures from -40°F to +212°F (-40°C to +100°C)
 - Very Flexible
 - Easy to exchange or retrofit
 - Silicone-free
 - Asbestos-free
- Standard lengths from stock

ø Index	Part No. jacket	Standard lengths ²⁾ XXXX (mm)
30.	▶ -	-
40.	▶ TR.40.14.	500 1000 1500 2000
50.	▶ TR.50.14.	500 1000 1500 2000
60.	▶ TR.60.14.	500 1000 1500 2000
65.	▶ TR.65.14.	500 1000 1500 2000
70.	▶ TR.70.14.	500 1000 1500 2000
85.	▶ TR.85.14.	500 1000 1500 2000
100.	▶ TR.100.14.	500 1000 1500 2000
125.	▶ TR.125.14.	500 1000 1500 2000

2) Special lengths upon request

Part No. with the desired standard value for the length **XXXX**

Example: **TR.60.14.500**

ø Index	Part No. jacket	Standard lengths ²⁾ XXXX (mm)
30.	▶ -	-
40.	▶ TR.40.18.	500 1000 1500 2000
50.	▶ TR.50.18.	500 1000 1500 2000
60.	▶ TR.60.18.	500 1000 1500 2000
65.	▶ TR.65.18.	500 1000 1500 2000
70.	▶ TR.70.18.	500 1000 1500 2000
85.	▶ TR.85.18.	500 1000 1500 2000
100.	▶ TR.100.18.	500 1000 1500 2000
125.	▶ TR.125.18.	500 1000 1500 2000

2) Special lengths upon request

Part No. with the desired standard value for the length **XXXX**

Example: **TR.60.18.500**

ø Index	Part No. jacket	Standard lengths ²⁾ XXXX (mm)
30.	▶ -	-
40.	▶ TR.40.19.	500 1000 1500 2000
50.	▶ TR.50.19.	500 1000 1500 2000
60.	▶ TR.60.19.	500 1000 1500 2000
65.	▶ TR.65.19.	500 1000 1500 2000
70.	▶ TR.70.19.	500 1000 1500 2000
85.	▶ TR.85.19.	500 1000 1500 2000
100.	▶ TR.100.19.	500 1000 1500 2000
125.	▶ TR.125.19.	500 1000 1500 2000

2) Special lengths upon request

Part No. with the desired standard value for the length **XXXX**

Example: **TR.60.19.500**

triflex® R interior separation - configure e-chains® easily

Quick and easy creation of interior separation layouts for triflex® R. After selecting the cables, they can be dragged & dropped into the e-chain® layout. The interior separation configurator creates a parts list of the e-chain® and the cables contained in the configuration. The configurations can be saved and reloaded. The entire configuration can be transferred to the shopping cart with a click.

- Quick and easy interior separation configurator
- Accounts for maximum filling rules for cables and hoses
- Creation of parts lists
- Easy inquiry and ordering

More information and interior separation configurator

► www.igus.com/triflexR-IA

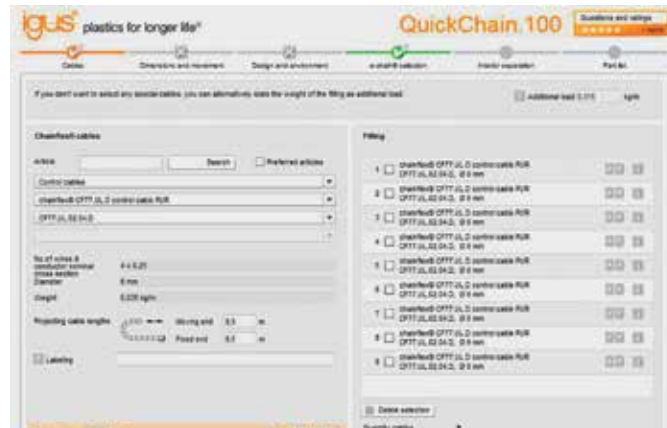

1. Select cables, hoses and lengths



2. Select e-chain® and size

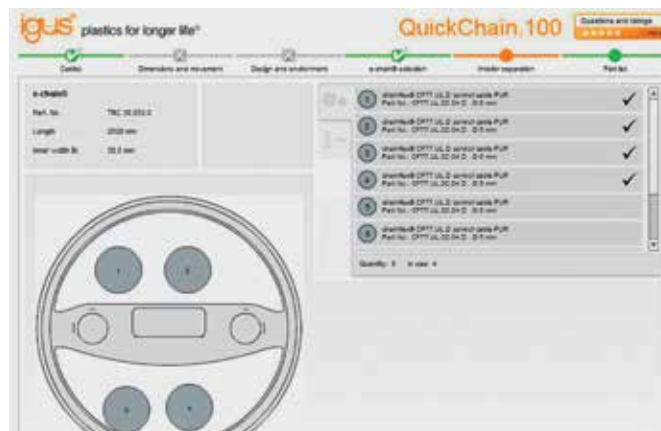

3. Fill the e-chain® with cables and hoses



4. Result: parts list, price and drawings

triflex® R - readychain® dress-packs

Customized system consisting of the triflex® R, chainflex® and connectors

- Eliminate storage costs for cables, e-chains® and plugs
- Shorten turnaround times by half, minimize your machine downtime
- Reduce the number of suppliers and orders by 75%

More information ► www.igus.com/readychain





RSE linear
retraction system

+ **Advantages:**

- Special linear guide avoids small bend radii
- Simple, linear retraction without loops, fiber-rods or guide rollers
- Up to 19.29" (490mm) retraction length possible
- Space-saving
- Maintenance-free igus® drylin® W linear unit
- For series TRC·TRE·TRCF* with \varnothing -index 1.57-3.94" (40-100mm)

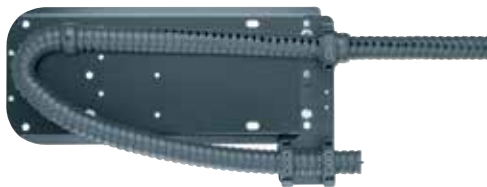

RS modular
retraction system

+ **Advantages:**

- For use with adverse environmental influences
- Retraction force provided by integrated fiber-rods
- For robots with a load capacity from approximately 22.05 lbs (10kg)
- Up to 26.38" (670mm) retraction length possible
- If a linear guide system is not needed
- For series TRC·TRE with \varnothing -index 1.57-3.94" (40-100mm)

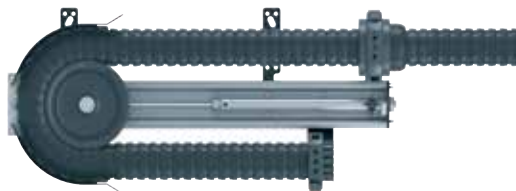

RSP pneumatic
retraction system

+ **Advantages:**

- Standard pneumatic components
- Sensor based monitoring possible
- For applications with a high fill weight
- Constant force over the complete travel
- For robots with a load capacity from approximately 110.2 lbs (50kg)
- Up to 30.71" (780mm) retraction length possible
- For series TRC·TRE·TRCF with a \varnothing -index of 2.36-4.92" (60-125mm)

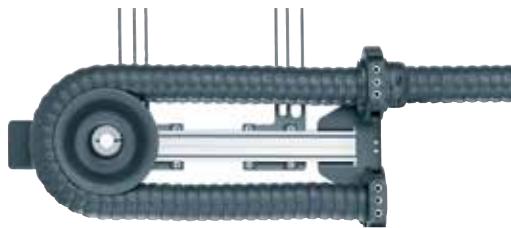

RSE wheel
retraction system

+ **Advantages:**

- For small robots, very light
- Up to 19.69" (500mm) retraction length possible
- For highly dynamic movements
- Cost-effective
- Maintenance-free igus® drylin® W linear unit
- For series TRC·TRE with \varnothing -index 1.57-1.97" (40-50mm)



RSEL linear,
retraction system

+ **Advantages:**

- Linear guidance even for highly dynamic applications
- For robots with high and medium payloads
- Up to 14.96" (380mm) retraction length possible
- Cost-effective
- For series TRC·TRE·TRCF with a \varnothing -index of 2.76-3.35" (70-85mm)

Choosing the right e-chain® size and retraction system

If you want to select a suitable retraction system yourself, please ensure that you observe the maximum cable diameter and usage data.

1

The largest cable diameter \varnothing ...

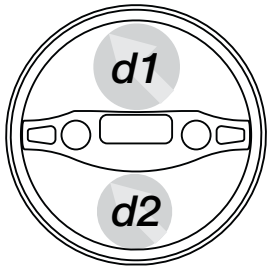

2

... and max. usable e-chain® cross section area ...

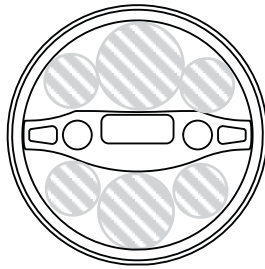

3

... determine the necessary \varnothing index of the triflex® R ...

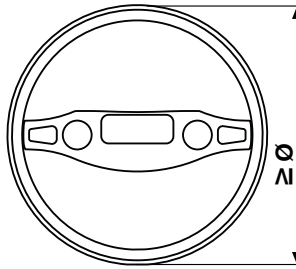

4

... select from 4 retraction systems options:



Max. cable \varnothing				Coverage of the entire area		Minimum \varnothing -index triflex® R	Retraction system				
1. chamber d1		2. chamber d2		in ²	(mm ²)		RSE linear	RS	RSP	RSE wheel	RSEL linear
in.	(mm)	in.	(mm)								
-	-	-	-		-	30-	-	-	-	-	-
< 0.59	< 15	< 0.51	< 13	< 0.775	< 500	40-	●	●	-	●	-
< 0.74	< 18.8	< 0.64	< 16.2	< 1.163	< 750	50-	●	-	-	●	-
< 0.89	< 22.5	< 0.77	< 19.5	< 1.550	< 1000	60-	●	●	●	-	-
< 0.88	< 22.3	< 0.88	< 22.3	< 61.5	< 1562	65-	●	-	●	-	-
< 1.10	< 28	< 0.94	< 24	< 2.713	< 1750	70-	●	●	●	-	●
< 1.30	< 33	< 1.10	< 28	< 3.875	< 2500	85-	●	●	●	-	●
< 1.48	< 37.5	< 1.28	< 32.5	< 4.650	< 3000	100-	●	●	●	-	-
< 1.69	< 43	< 1.69	< 43	< 6.975	< 4500	125-	-	-	●	-	-

● Available - Not Available



Interior separation configurator - quick and easy creation of interior layouts for triflex® R.
More information ► www.igus.com/triflexR-IA

Selection tool for triflex® R retraction systems

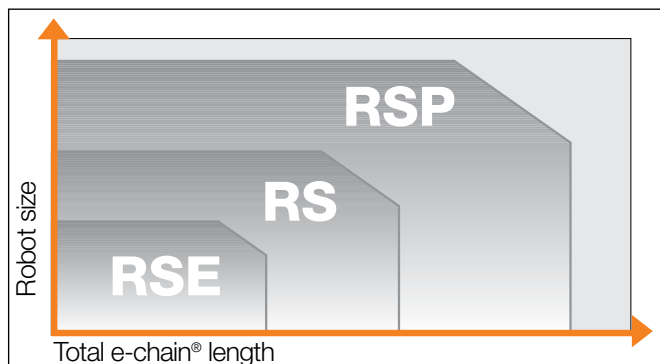

For series	RSE linear \varnothing Index	RS \varnothing Index	RSP \varnothing Index	RSE Wheel \varnothing Index	RSEL linear \varnothing Index
TRC	40 - 100	40 - 100	60 - 125	40 - 50	70 - 85
TRE	40 - 100	40 - 100	60 - 125	40 - 50	70 - 85
TRCF	65 - 100	-	65 - 100	-	-
TRL*	-	-	-	-	-
TRLF*	-	-	-	-	-

* Retraction systems not available for this series

Up to 19.29" (490mm) retraction length possible with triflex® RSE

For TRC-TRE-TRCF series with a Ø index of 1.57 - 4.92" (40-125mm)

Simple, linear retraction without loops, fiber-rods or guide rollers

Special linear guide avoids small bend radii

Maintenance-free igus® drylin® W linear unit

Custom connection possibilities using adapter consoles

Compact design, no loops

Cost-effective

triflex® RSE linear retraction system

The more complex the automated production technology, the greater the requirements placed on the energy supply system. It is increasingly the case that not only electric power and fluids have to be supplied to production robots; but also laser cables and supply hoses for rivets, pins and screws. As these often cannot function with small bend radii, the new triflex® RSE relies on very easy linear retraction without loops and spring rods or deflection rollers. The purpose of the triflex® RSE retraction system is to hold the e-chain® as closely as possible to the robot arm in order to prevent the e-chain® from intruding upon or blocking the robot's movements.

- Simple, linear retraction without bends, fiber-rods or guide rollers
- For series TRC-TRE-TRCF with a ø-index of 1.57 - 4.92" (40-125mm)
- Special linear guide avoids small bend radii
- Up to 19.29" (490mm) retraction length possible
- Cost-effective
- Maintenance-free igus® drylin® W linear unit

Optional accessories - RSE linear, cost-effective linear retraction system



Adapter brackets for customized mounting options



Clamps - axis 6 - for triflex® R mounting bracket



igus® TR.RSE system on test robot



Lightweight, linear retraction system for small robots in sizes 40 and 50



Linear TR.RSE retraction system for sizes 2.36 - 3.94" (60-100) with attachment brackets for a wide variety of robot models

Dimensions - RSE linear retraction system

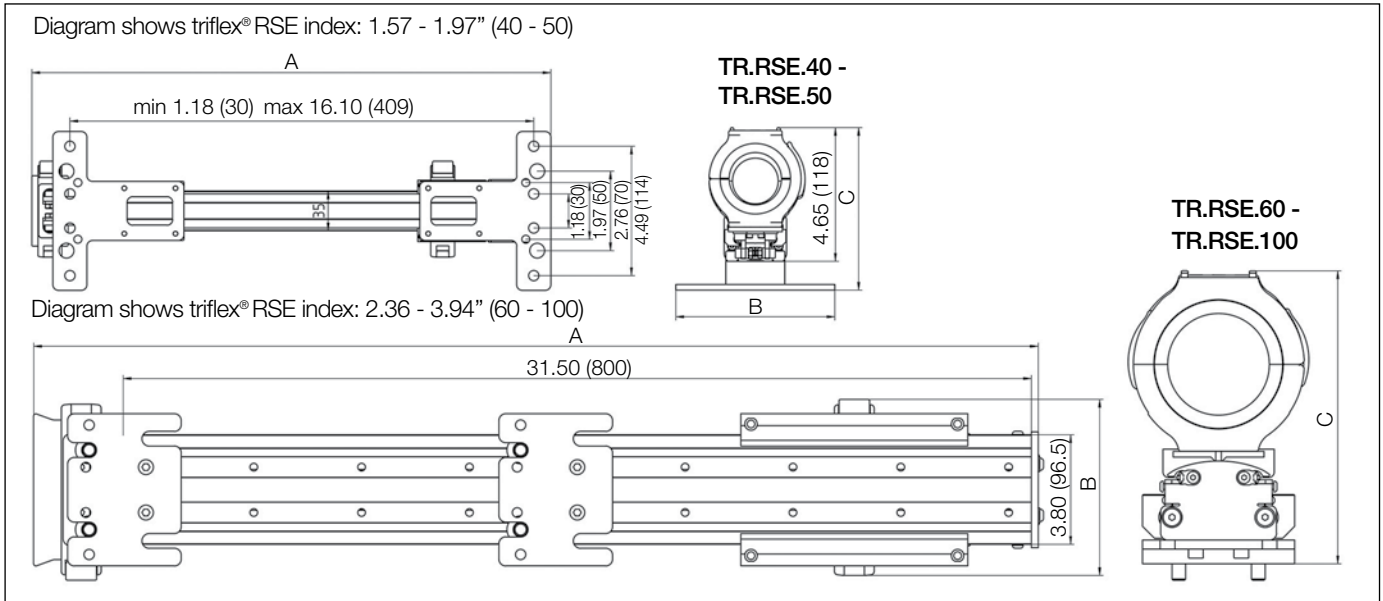

Possible installation positions for TR.RS.60 - TR.RS.100 | RSE linear

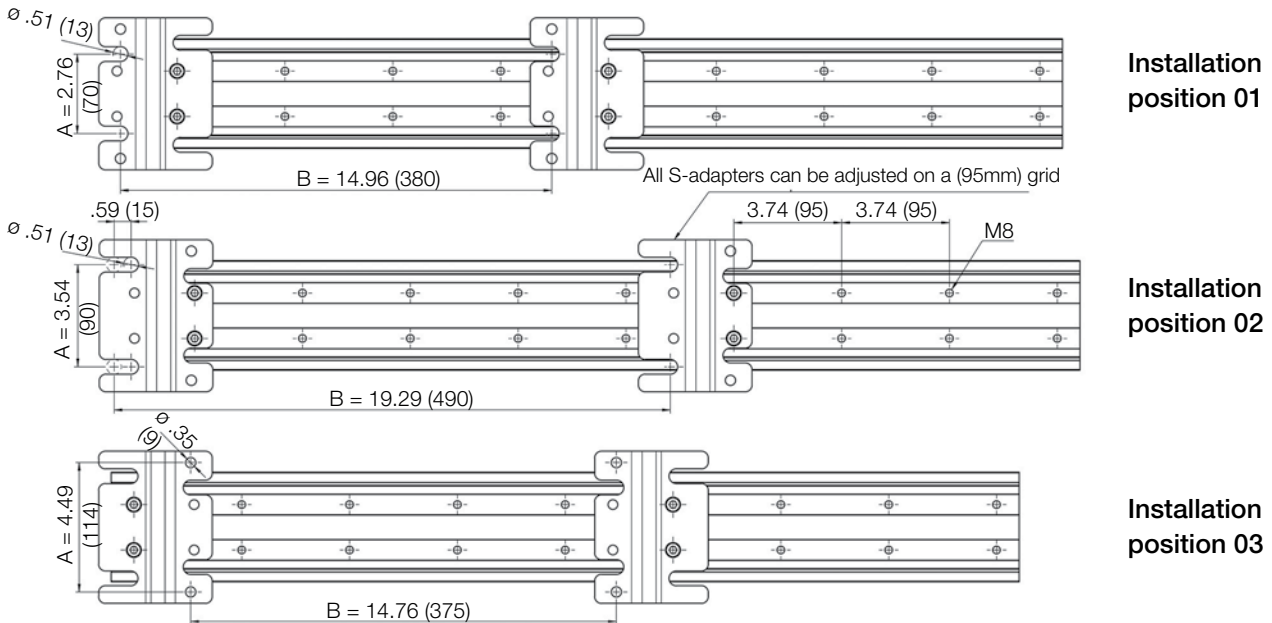

Installation position 01

A	B	Thread size
in. (mm)	in. (mm)	
2.76 (70)	7.48 (190)	M12
2.76 (70)	11.22 (285)	M12
2.76 (70)	14.96 (380)	M12
2.76 (70)	18.70 (475)	M12
2.76 (70)	22.44 (570)	M12
2.76 (70)	26.18 (665)	M12
2.76 (70)	29.92 (760)	M12

Installation position 02

A	B	Thread size
in. (mm)	in. (mm)	
3.54 (90)	6.89 - 8.07 (175 - 205)	M12
3.54 (90)	10.63 - 11.81 (270 - 300)	M12
3.54 (90)	14.37 - 15.55 (365 - 395)	M12
3.54 (90)	18.11 - 19.29 (460 - 490)	M12
3.54 (90)	21.85 - 23.03 (555 - 585)	M12
3.54 (90)	25.59 - 26.77 (650 - 680)	M12
3.54 (90)	29.33 - 30.51 (745 - 775)	M12

Installation position 03

A	B	Thread size
in. (mm)	in. (mm)	
4.49 (114)	7.28 (185)	M8
4.49 (114)	11.02 (280)	M8
4.49 (114)	14.76 (375)	M8
4.49 (114)	18.50 (470)	M8
4.49 (114)	22.24 (565)	M8
4.49 (114)	25.98 (660)	M8

Ø Index	Part No. RSE linear	Retraction length ¹⁾		A		B		C		Weight		Part No. RSE support
		≤ in.	≤ (mm)	in.	(mm)	in.	(mm)	in.	(mm)	lb	(kg)	
30.	-	-	-	-	-	-	-	-	-	-	-	-
40.	▶ TR.RSE.40	11.42	(290)	17.99	(457)	5.51	(140)	5.63	(143)	3.09	(1.4)	-
50.	▶ TR.RSE.50	11.42	(290)	18.70	(475)	5.51	(140)	5.94	(151)	3.75	(1.7)	-
60.	▶ TR.RSE.60	19.29	(490)	34.17	(868)	5.28	(134)	9.09	(231)	21.83	(9.9)	TR.914.973.60
65.	▶ TR.RSE.65	19.29	(490)	34.65	(880)	5.28	(134)	9.09	(231)	22.04	(10.0)	TR.914.973.65
70.	▶ TR.RSE.70	19.29	(490)	34.57	(878)	6.10	(155)	1.02	(258)	22.04	(10.0)	TR.914.973.70
85.	▶ TR.RSE.85	19.29	(490)	34.84	(885)	6.10	(155)	1.02	(258)	22.04	(10.0)	TR.914.973.85
85. (R 240)	▶ TR.RSE.85.240	19.29	(490)	34.84	(885)	6.10	(155)	1.02	(258)	22.04	(10.0)	-
100.	▶ TR.RSE.100	19.29	(490)	34.88	(886)	6.69	(170)	1.04	(264)	22.49	(10.2)	TR.914.973.100

1) These are the maximum values. In normal operation a filling of no more than 70% is advised.

Please order matching triflex® R e-chain® separately. Optional RSE support must be ordered separately.

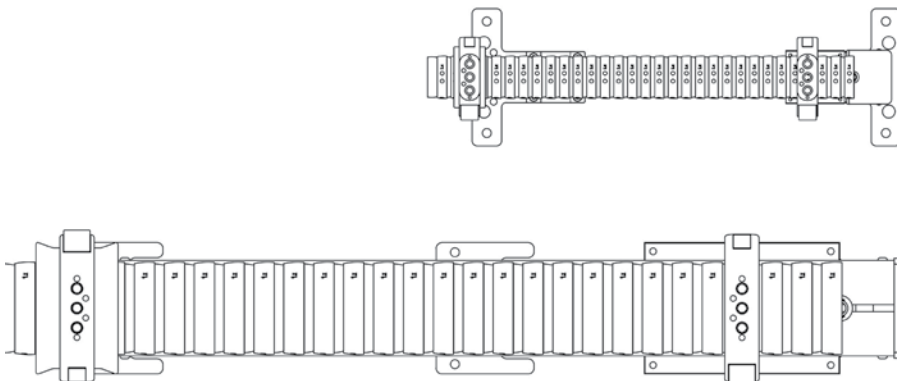
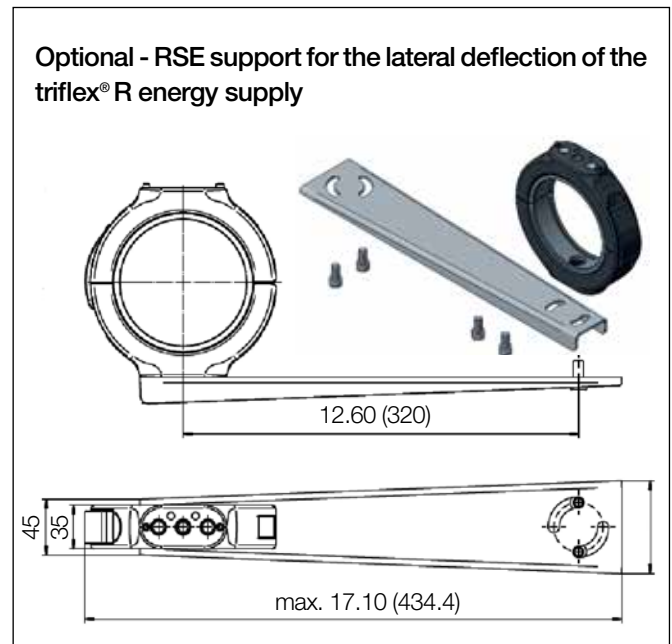
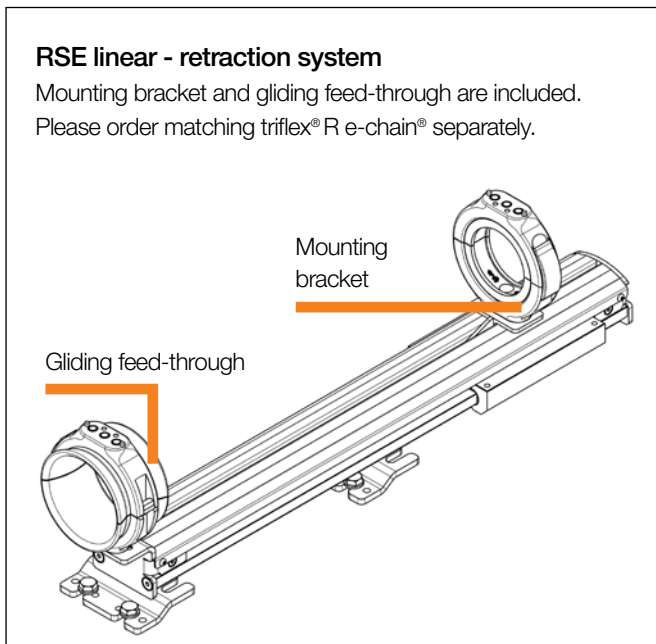

Order key

TR.RSE.XX



System design | RSE linear and matching e-chain®

Matching triflex® R e-chain® for RSE linear

TRC .XX.R.0

TRE .XX.R.0.B

TRCF.XX.R.0



Excess length in direction **A1** +

Dimension **A** +

Excess length in direction **A6** =

Total e-chain® length

Limit protector

RSE linear system

(without e-chain®) +

Mounting bracket +

Gliding feed-through =

TR.RSE.XX

IMPORTANT - Ball end of triflex® must run in direction of the end of arm tool

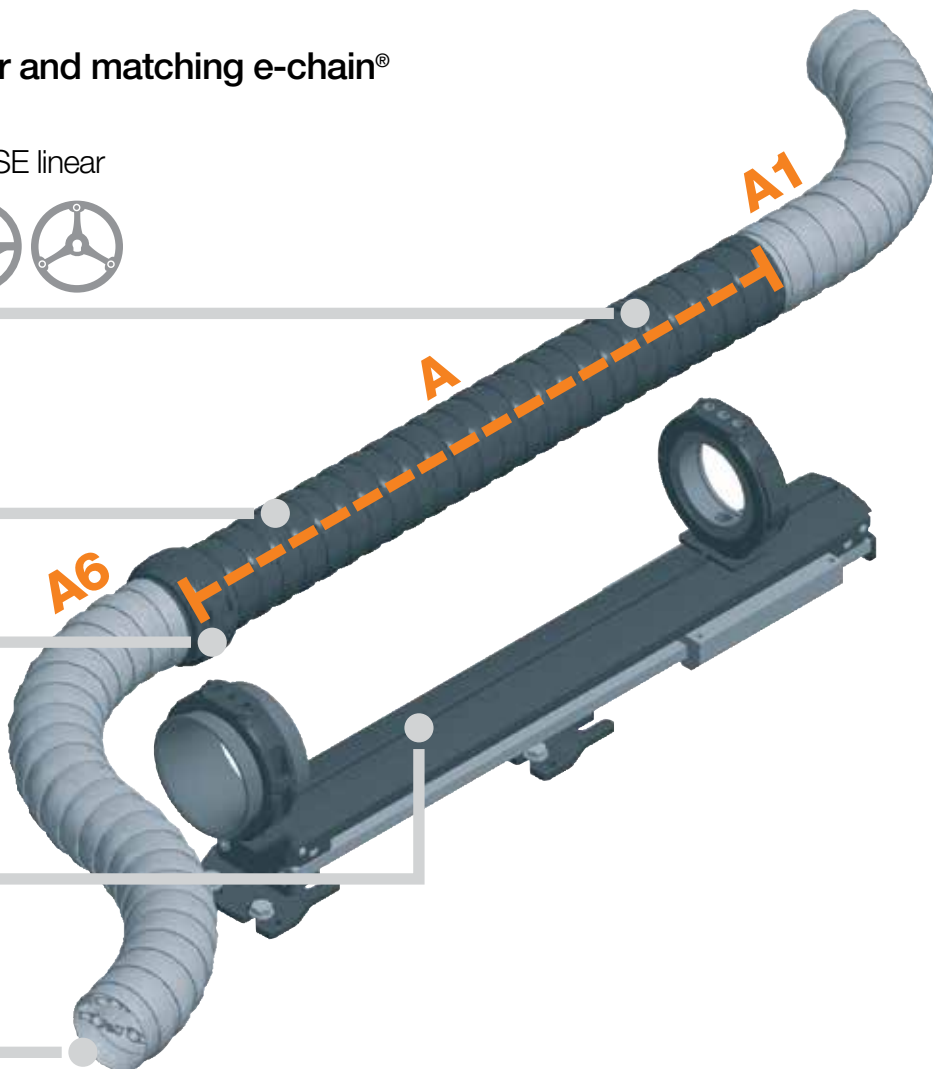

Sample order of a complete TR.RSE linear system, Ø index 1.57" (40), and e-chain® length: 6.56" (2 m)

System	Insert Ø index XX	TR.RSE.XX
+ e-chain®	Insert Ø index XX / Insert bend radius R / Insert standard length LLLL in meters	2 m TRC.XX.R.0
+ protector	Protector with quick-lock fastener	TR.XX.30
Order text:	TR.RSE.40. + 2 m TRC.40.058.0 + TR.40.30	



Order key e-chains®

TRC .XX.R.0

TRE .XX.R.0.B

TRCF .XX.R.0



Default color black

R Bend radius

Ø Index

e-chains® series

Product range - Matching e-chains® and protectors for RSE linear

∅ Index	Part No. TRC enclosed	Part No. TRE "easy" design	Part No. TRCF with snap lock mechanism	Protector with screw fastener	Protector with quick-lock fastener
30.	▶ -	-	-	-	-
40.	▶ TRC.40.058.0	TRE.40.058.0.B	-	TR.40.10	TR.40.30
50.	▶ TRC.50.080.0	TRE.50.080.0.B	-	TR.50.10	-
60.	▶ TRC.60.087.0	TRE.60.087.0.B	-	TR.60.10	TR.60.30
65.	▶ -	-	TRCF.65.100.0	TR.65.10	-
70.	▶ TRC.70.110.0	TRE.70.110.B	-	TR.70.10	TR.70.30
85.	▶ TRC.85.135.0	TRE.85.135.B	TRCF.85.135.0	TR.85.10	TR.85.30
85. (R 240)	▶ -	-	TRCF.85.240.0	TR.85.240.10	-
100.	▶ TRC.100.145.0	TRE.100.145.0.B/C ¹⁾	TRCF.100.145.0	TR.100.10	TR.100.30

1) Available for B- and C-versions

Please order e-chains® as piece parts and purchase a protector for each one.

Please order protectors with screw connections or quick release as limit protectors.

To calculate the total chain length, add the desired excess length from axis 1 and axis 6 to dimension A (lower table). Additionally, at least 1 limit protector must be ordered. Please note that all triflex® R e-chains can be lengthened and shortened individually and can be customized to meet the needs of your application.

Calculating the overall chain length - RSE linear e-chains®

∅ Index	Bend radius <i>R</i>		A	
	in.	(mm)	in.	[mm]
30.	▶ -	-	-	-
40.	▶ 2.28	058	15.35	390
50.	▶ 3.15	080	15.35	390
60.	▶ 3.43	087	29.53	750
65.	▶ 3.94	100	29.53	750
70.	▶ 4.33	110	29.53	750
85.	▶ 5.31	135	29.53	750
85. (R 240)	▶ 9.45	240	29.53	750
100.	▶ 5.71	145	29.53	750
125.	▶ 7.17	182	29.53	750

Excess length in direction **A6** + Dimension **A** +
 excess length in direction **A1** = total chain length

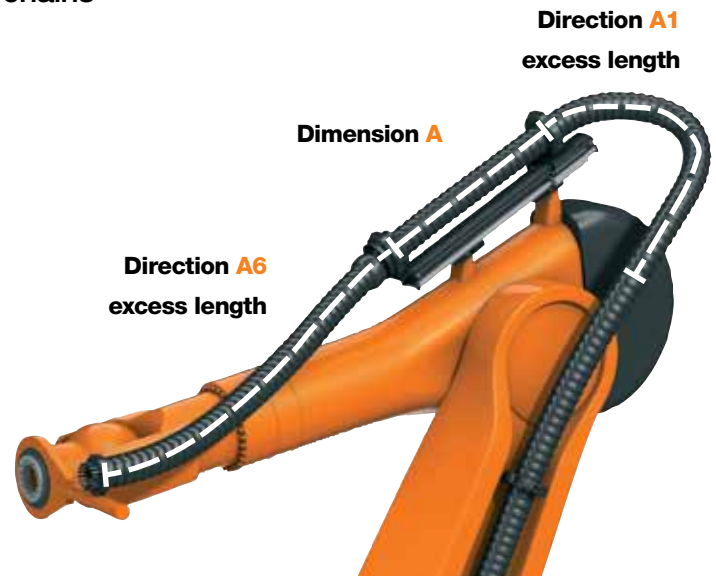

triflex® R length calculation for RSE linear

Up to 26.38" (670mm) retraction length possible with triflex® RS

Gliding feed-through for close parallel guidance to the robotic arm

Mounting brackets for secure fastening

For TRC and TRE (matching e-chains® must be ordered separately)

Single module, space-saving and quickly mounted on robot

End stop for a defined yet free movement

Retraction force provided by integrated fiber-rods

triflex® RS Modular retraction system

triflex® RS is a retraction system for robots with medium and high load-bearing capacity. The triflex® RS is used as a space-saving guide for the multi-dimensionally moving triflex® R in parallel to the robot arm. Integrated fiber rods generate a directed camber to prevent undesirable loops from forming in the working space of the robot. This permits applications with very tight installation space to be realized as well. triflex® RS provides the option to reliably implement the energy supply system to the tool, without placing stress on the cable, therefore making a key contribution to minimizing downtimes.

- Saves space - low interfering contours, closely routed on the robotic arm
- System solution tested by the tens of thousands
- Universally applicable
- Integrated fiber rods - no external mechanical components such as springs or steel wires needed!

Optional accessories - RS modular retraction system



Cover - for additional installation space and extreme motions



Adjustment unit - accurate adjustment of the assembly position



Adapter brackets for customized mounting options



Clamps - axis 6 - for triflex® R mounting bracket

triflex® R - RS - Application example
For Series TRC / TRE
RS - R(etraction) S(ystem)



triflex® RS for a lean chain guide. The triflex® RS is used as a space-saving guide for the multi-dimensionally moving triflex® R in parallel to the robot arm.
Video at ► www.igus.com/triflexR



Optional: triflex® RS with cover - creates additional installation space on the robot

Installation height - RS modular retraction system

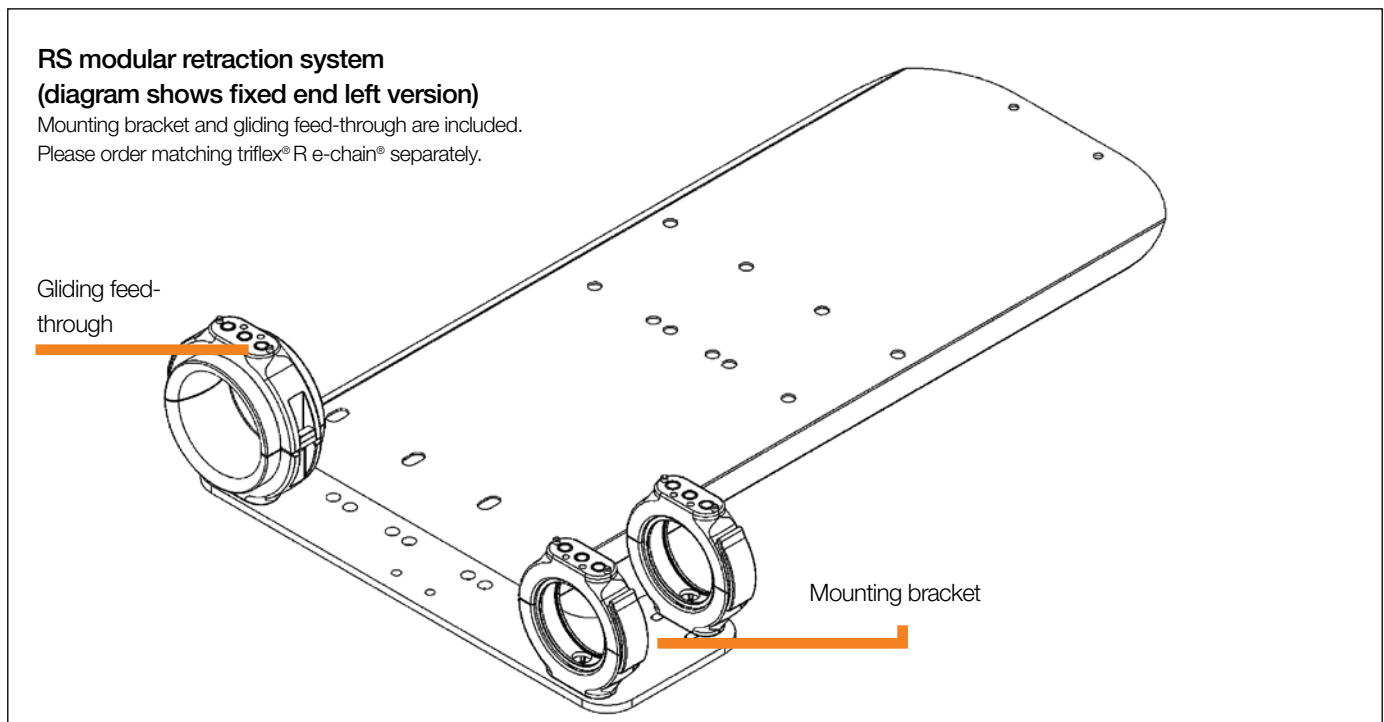
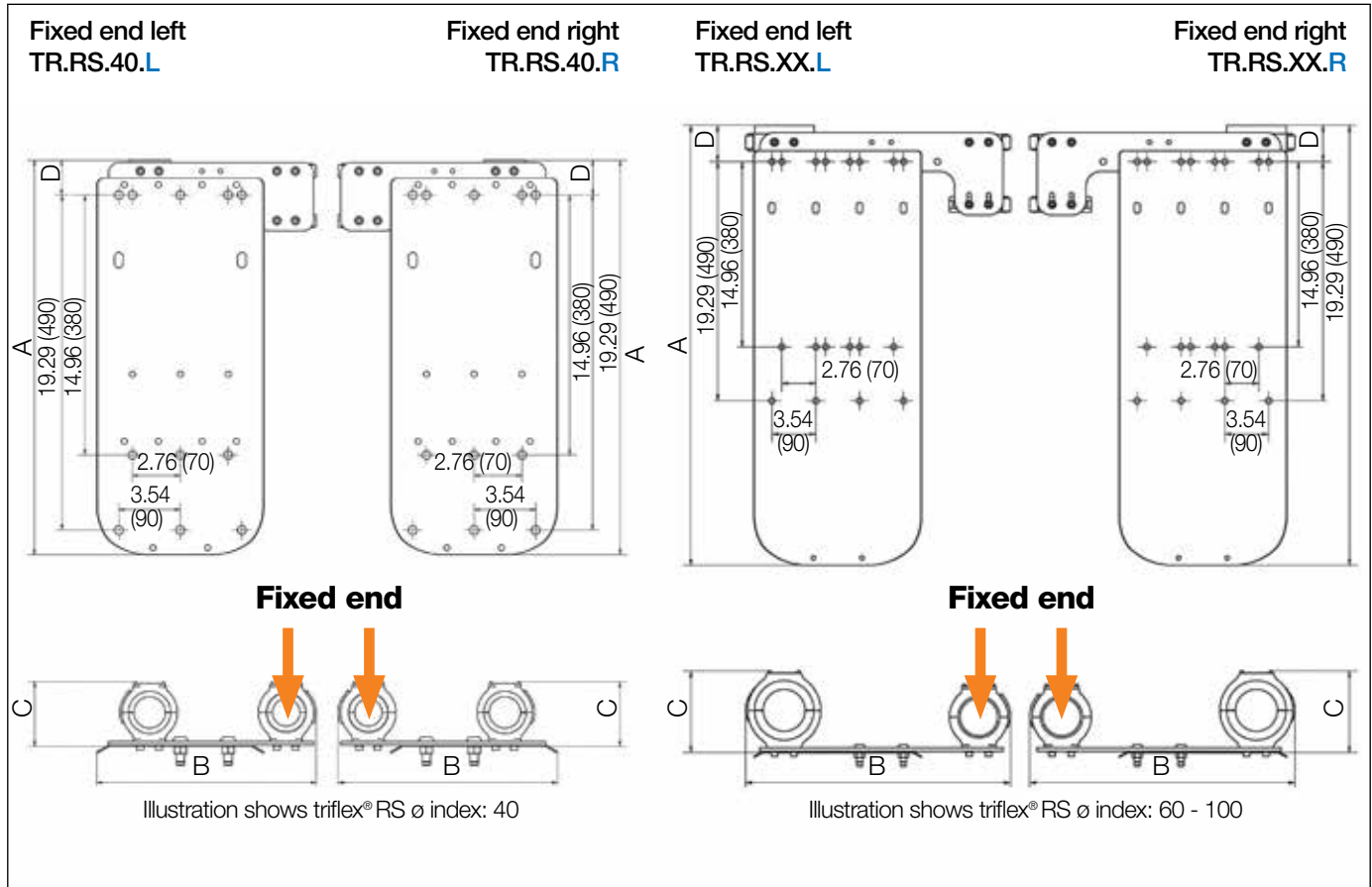

Product range - RS modular retraction system

triflex® RS - Fastening point, right		Retraction										Weight	
Universal module TRS	Part No.	Length ¹⁾		A		B		C		D		lb	(kg)
For Series TRC	For Series TRE	≤ in.	≤ (mm)	in.	(mm)	in.	(mm)	in.	(mm)	in.	(mm)		
TRC.RS.40.R	▶ TRE.RS.40.R.B	18.11	(460)	24.41	(620)	11.85	(301)	3.74	(95)	2.01	(51)	7.72	(3.5)
TRC.RS.60.R	▶ TRE.RS.60.R.B	21.65	(550)	34.84	(885)	20.79	(528)	5.91	(150)	2.56	(65)	19.18	(8.7)
TRC.RS.70.R	▶ TRE.RS.70.R.B	24.41	(620)	34.84	(885)	21.46	(545)	6.57	(167)	2.56	(65)	20.28	(9.2)
TRC.RS.85.R	▶ TRE.RS.85.R.B	26.38	(670)	34.84	(885)	22.24	(565)	6.57	(167)	2.56	(65)	20.94	(9.5)
TRC.RS.100.R	▶ TRE.RS.100.R.B	22.83	(580)	35.93	(912.5)	24.17	(614)	6.57	(167)	4.25	(108)	25.35	(11.5)

triflex® RS - Fastening point, left		Retraction										Weight	
Universal module	Part No.	Length ¹⁾		A		B		C		D		lb	(kg)
For Series TRC	For Series TRE	≤ in.	≤ (mm)	in.	(mm)	in.	(mm)	in.	(mm)	in.	(mm)		
TRC.RS.40.L	▶ TRE.RS.40.L.B	18.11	(460)	24.41	(620)	11.85	(301)	3.74	(95)	2.01	(51)	7.72	(3.5)
TRC.RS.60.L	▶ TRE.RS.60.L.B	21.65	(550)	34.84	(885)	20.79	(528)	5.91	(150)	2.56	(65)	19.18	(8.7)
TRC.RS.70.L	▶ TRE.RS.70.L.B	24.41	(620)	34.84	(885)	21.46	(545)	6.57	(167)	2.56	(65)	20.28	(9.2)
TRC.RS.85.L	▶ TRE.RS.85.L.B	26.38	(670)	34.84	(885)	22.24	(565)	6.57	(167)	2.56	(65)	20.94	(9.5)
TRC.RS.100.L	▶ TRE.RS.100.L.B	22.83	(580)	35.93	(912.5)	24.17	(614)	6.57	(167)	4.25	(108)	25.35	(11.5)

Product range - with cover

triflex® RS - Fastening point, right, with cover		Retraction										Weight	
Universal module TRS	Part No.	Length ¹⁾		A		B		C		D		lb	(kg)
For Series TRC	For Series TRE	≤ in.	≤ (mm)	in.	(mm)	in.	(mm)	in.	(mm)	in.	(mm)		
TRC.RS.40.RC	▶ TRE.RS.40.RC.B	18.11	(460)	24.41	(620)	11.85	(301)	3.74	(95)	2.01	(51)	7.72	(3.5)
TRC.RS.60.RC	▶ TRE.RS.60.RC.B	21.65	(550)	34.84	(885)	20.79	(528)	5.91	(150)	2.56	(65)	19.18	(8.7)
TRC.RS.70.RC	▶ TRE.RS.70.RC	24.41	(620)	34.84	(885)	21.46	(545)	6.57	(167)	2.56	(65)	20.28	(9.2)
TRC.RS.85.RC	▶ TRE.RS.85.RC	26.38	(670)	34.84	(885)	22.24	(565)	6.57	(167)	2.56	(65)	20.94	(9.5)
TRC.RS.100.RC	▶ TRE.RS.100.RCB	22.83	(580)	35.93	(912.5)	24.17	(614)	6.57	(167)	4.25	(108)	25.35	(11.5)

triflex® RS - Fastening point, left, with cover		Retraction										Weight	
Universal module	Part No.	Length ¹⁾		A		B		C		D		lb	(kg)
For Series TRC	For Series TRE	≤ in.	≤ (mm)	in.	(mm)	in.	(mm)	in.	(mm)	in.	(mm)		
TRC.RS.40.LC	▶ TRE.RS.40.LC.B	18.11	(460)	24.41	(620)	11.85	(301)	3.74	(95)	2.01	(51)	7.72	(3.5)
TRC.RS.60.LC	▶ TRE.RS.60.LC.B	21.65	(550)	34.84	(885)	20.79	(528)	5.91	(150)	2.56	(65)	19.18	(8.7)
TRC.RS.70.LC	▶ TRE.RS.70.LC.B	24.41	(620)	34.84	(885)	21.46	(545)	6.57	(167)	2.56	(65)	20.28	(9.2)
TRC.RS.85.LC	▶ TRE.RS.85.LC	26.38	(670)	34.84	(885)	22.24	(565)	6.57	(167)	2.56	(65)	20.94	(9.5)
TRC.RS.100.LC	▶ TRE.RS.100.LCB	22.83	(580)	35.93	(912.5)	24.17	(614)	6.57	(167)	4.25	(108)	25.35	(11.5)

Up to 30.71" (780mm) retraction length possible
with TRC, TRE and TRCF e-chains®
(please order matching e-chain® separately)

triflex® RSP Pneumatic retraction system

Increased protection against failure by
optional end position monitoring

Standard pneumatic
components for
easy integration

Pressure compensation unit for
an adjustable retraction force

Open system, low profile design

Custom connection possibilities
using adapter consoles

Double retraction distance
relative to the overall length

triflex® RSP prevents loops on the robot head, with a continuously adjustable retraction force. Extension lengths of up to 30.71" (780mm) enable a secure guidance of the cables and hoses, even with large arm diameters and very complex movements. The retraction forces can be adjusted using a pneumatic cylinder. Whether light or heavy fill weights, long or short robot arms - with the igus® RSP retraction system the retraction force can be adjusted to the individual application.

- For axis 3-6 on industrial robots
- Larger retraction forces than RS system
- Even larger e-chains® up to Ø 4.92" (125mm) can be guided safely
- Almost constant force over the complete travel, even with heavy fill weights
- The end position can be monitored so damage can be prevented
- Mounting options for numerous robot models and manufacturers with adapter consoles
- Very low energy consumption with integrated air reservoir

Optional accessories - RSP pneumatic retraction system



Adjustment unit - for accurate adjustment of the system position



Adapter consoles - for custom mounting options



Axis 6 clamp - for triflex®R mounting bracket

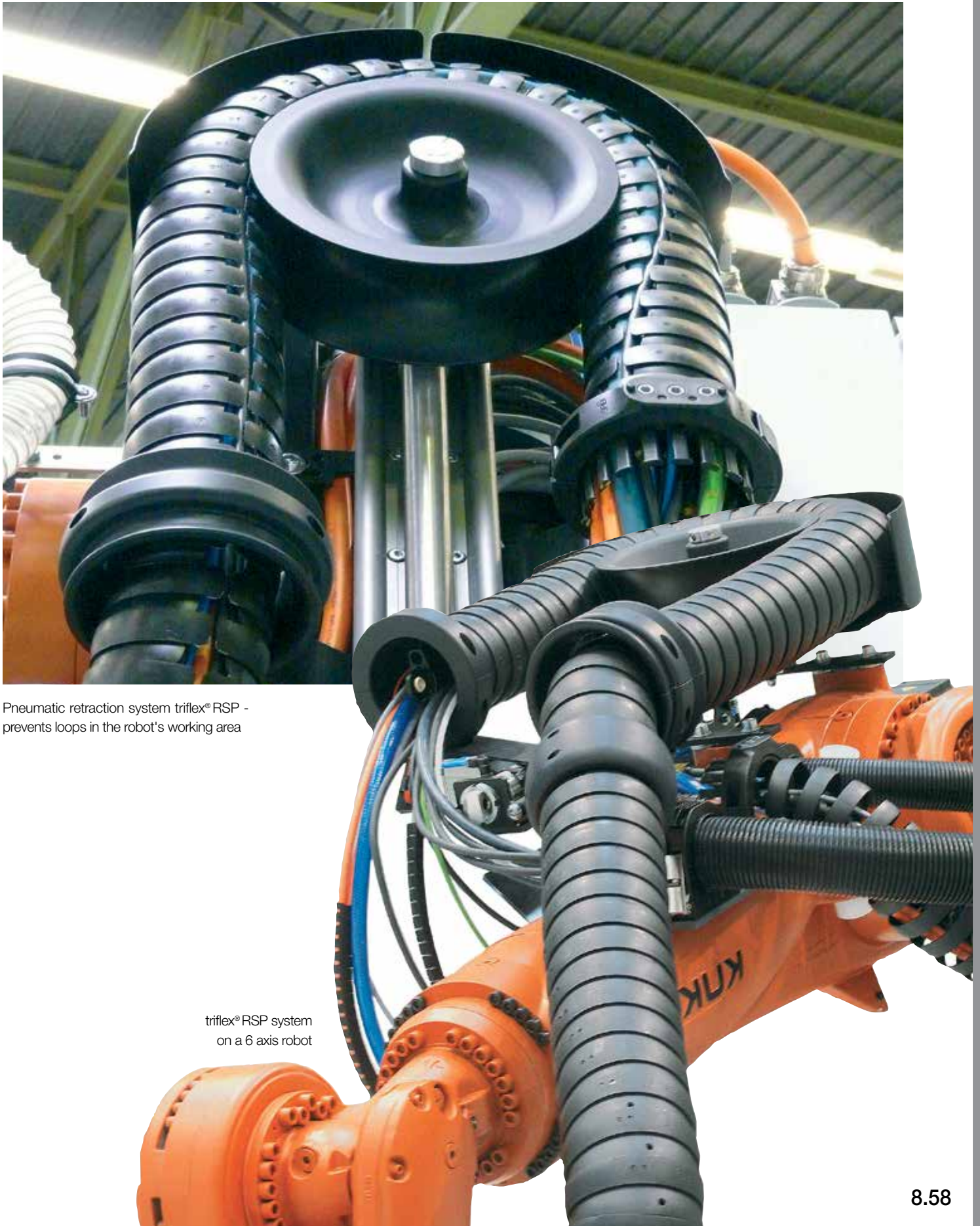

Pneumatic retraction system triflex® RSP - prevents loops in the robot's working area

triflex® RSP system
on a 6 axis robot

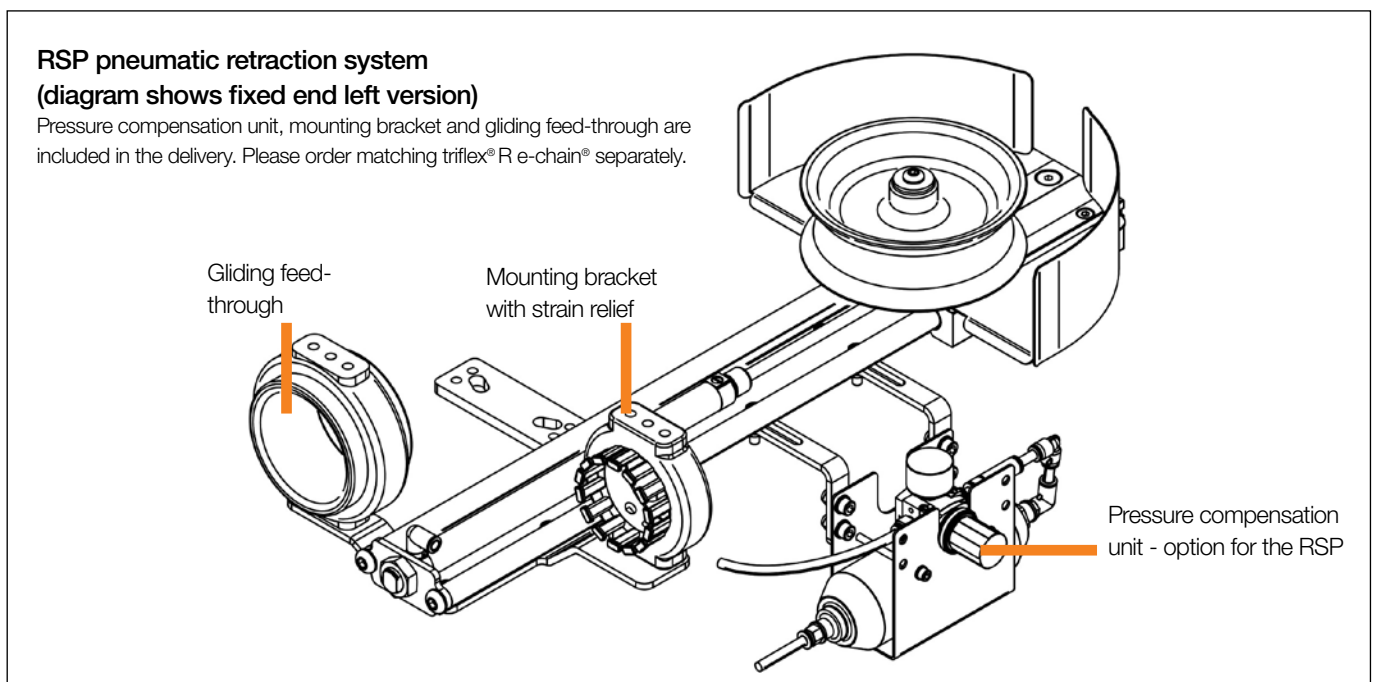
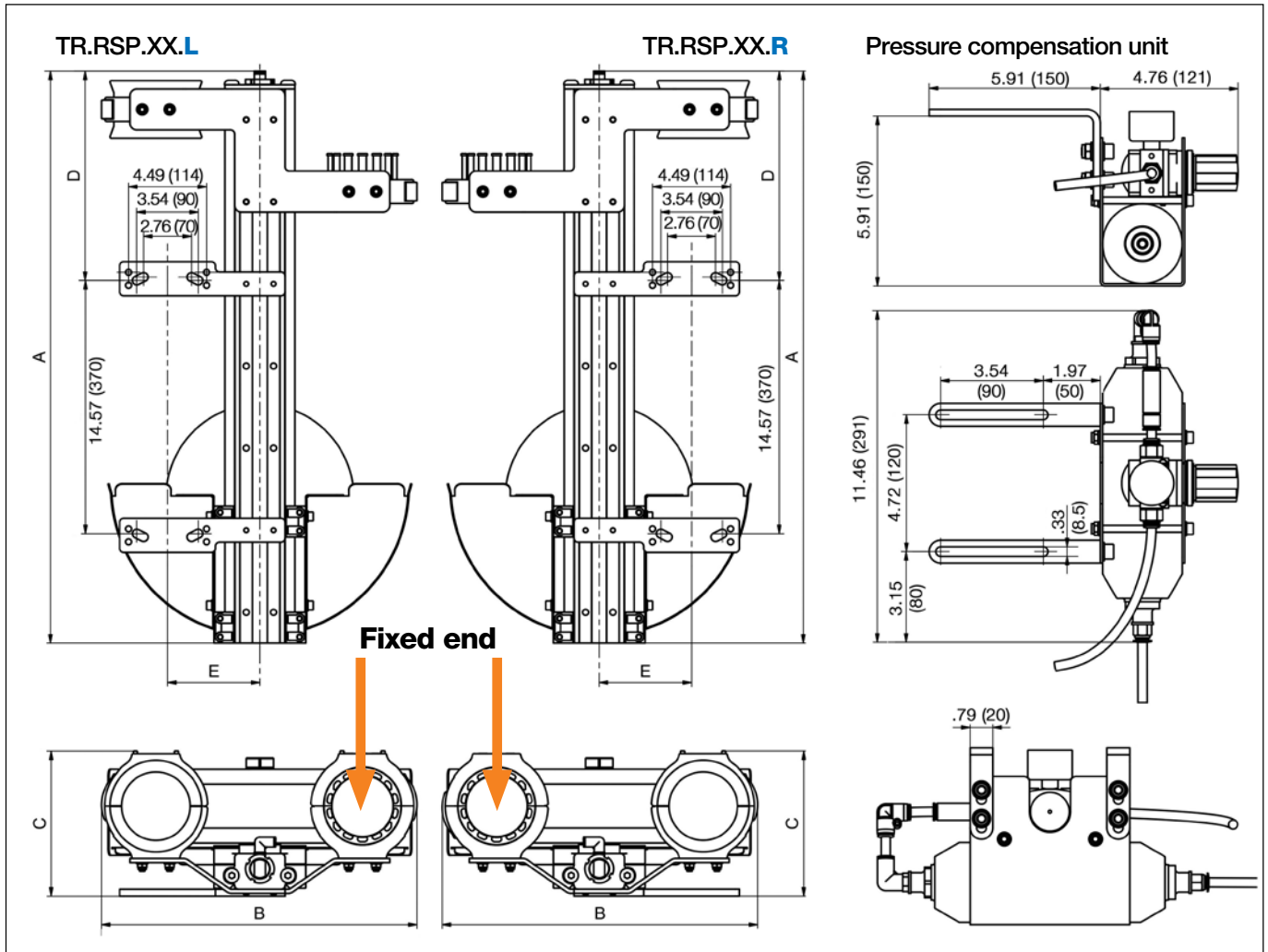

Product range - RSP Pneumatic Retraction System - for TRC TRE

For Series Ø	RSP Left fixed point Part. No.	RSP Right fixed point Part. No.	Retract travel maximum in. (mm) ¹⁾	Dimension A in. (mm)	Dimension B in. (mm)	Dimension C in. (mm)	Dimension D in. (mm)	Dimension E in. (mm)	Weight lb. (kg)
.30.	▶ -	-	-	-	-	-	-	-	-
.40.	▶ -	-	-	-	-	-	-	-	-
.50.	▶ -	-	-	-	-	-	-	-	-
.60.	▶ TR.RSP.60.L	TR.RSP.60.R	22.83 (580)	31.18 (792)	15.59 (396)	6.97 (177)	10.91 (277)	5.31 (135)	35.49 (16.1)
.65.	▶ TR.RSP.65.L	TR.RSP.65.R	22.83 (580)	31.18 (792)	15.59 (396)	6.97 (177)	10.91 (277)	5.31 (135)	35.49 (16.1)
.70.	▶ TR.RSP.70.L	TR.RSP.70.R	22.83 (580)	31.18 (792)	15.59 (396)	6.97 (177)	10.91 (277)	5.31 (135)	35.71 (16.2)
.85.	▶ TR.RSP.85.L	TR.RSP.85.R	24.41 (620)	32.91 (836)	18.15 (461)	8.39 (213)	12.05 (306)	5.31 (135)	42.77 (19.4)
.85.(R240)	▶ -	-	-	-	-	-	-	-	-
.100.	▶ TR.RSP.100.L	TR.RSP.100.R	24.41 (620)	33.27 (845)	18.39 (467)	8.39 (213)	12.05 (306)	5.31 (135)	42.99 (19.5)
.125.	▶ TR.RSP.125.L	TR.RSP.125.R	30.71 (780)	41.06 (1043)	22.44 (570)	9.65 (245)	15.94 (405)	5.31 (135)	53.13 (24.1)

Pressure compensation unit, mounting bracket, and feed-through guides are included.

Please order matching triflex® e-chain® separately.

1) These are maximum values. We do not recommend using more than 70% during normal operations to preserve a margin of error.

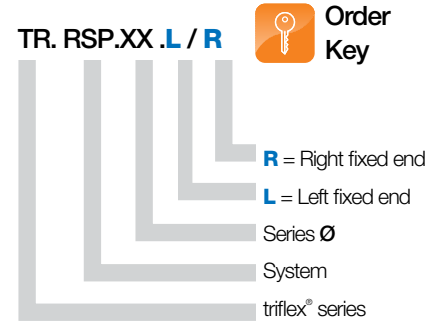
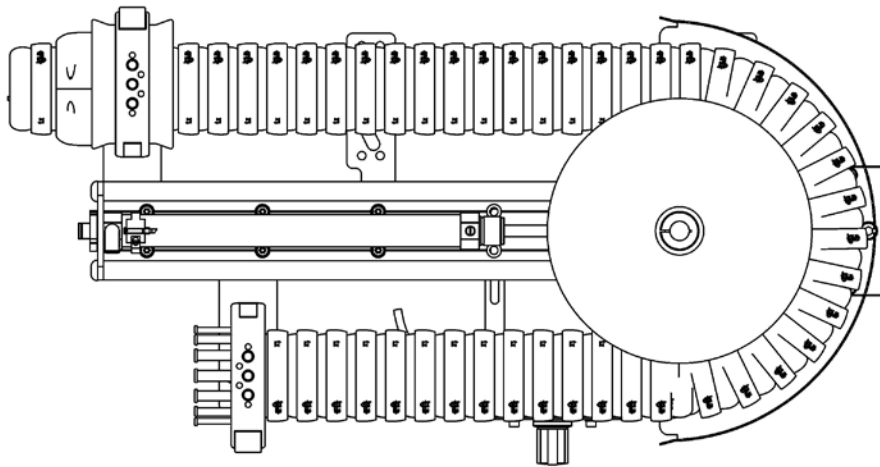

System design | RSP and matching e-chains®

Standard chain length for each system. See chart below



Additional chain from gliding feed-through bracket to end of arm tool

IMPORTANT - Ball end of triflex® must run in direction of the end of arm tool

RSP system (without e-chain®)
+ pressure compensation unit
+ mounting bracket
+ gliding feed-through =
TR.RSP.XX.L or **TR.RSP.XX.R**

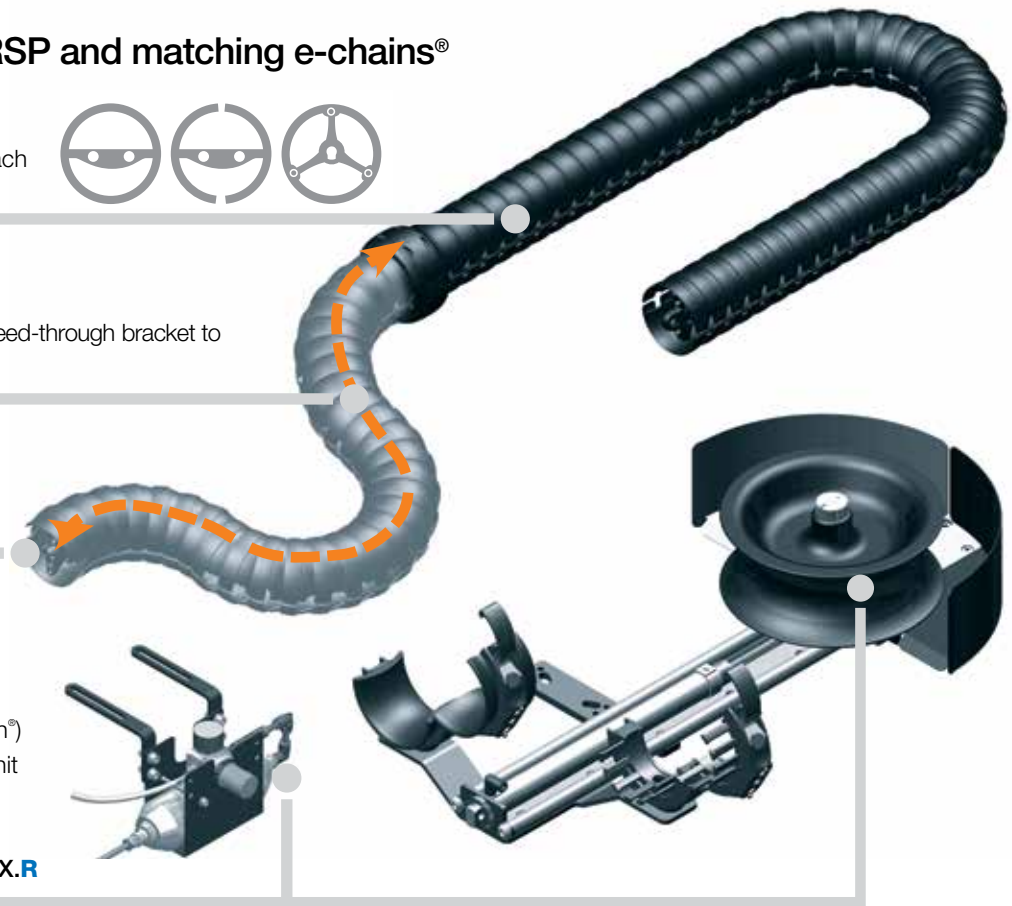

Sample order of a complete TR-RSP system, Ø-Index 60, fixed end on the left, and e-chain®

System	Insert Ø index XX / select fixed end -L / -R	TR.RSP.60.L
+ e-chain®	Standard Length TRE-60-080-0-B x 1489mm + Additional Length TRE-60-080-0-B x 1500mm = 2989mm	
+ Protector:		TR.60.30

Calculating the overall chain length - RSP e-chains®

ø		Bend radius <i>R</i>		e-chain® length*		Number of e-chains® links	Total e-chain® length (mm)
		in.	(mm)	in.	(mm)		
30.	▶	-	-	-	-	-	-
40.	▶	-	-	-	-	-	-
50.	▶	-	-	-	-	-	-
60.	▶	3.43	087	58.62	1489	73	LLLL + 58.62 (1489)
65.	▶	3.94	100	56.38	1432	62	LLLL + 56.38 (1432)
70.	▶	4.33	110	58.43	1484	58	LLLL + 58.43 (1484)
85.	▶	5.31	135	63.86	1622	53	LLLL + 63.86 (1622)
85. (<i>R 240</i>)	▶	-	-	-	-	-	-
100.	▶	5.71	145	65.20	1656	48	LLLL + 65.20 (1656)
125.	▶	7.17	182	77.24	1962	44	LLLL + 77.24 (1962)

*Values are related to the e-chain® length within the system

Please add the e-chain® length within the system to the standard length **LLLL** (measured from the gliding feed-through) to get the **overall chain length**

triflex® RSE Wheel retraction system

Up to 19.69" (500mm) retraction
length possible with triflex® RSE

For TRC and TRE with ø index 1.57 and 1.97" (40 and 50mm)

Delivered with left or right
fixed end already assembled

Custom connection possibilities
using adapter consoles

Maintenance-free igus®
drylin® W linear unit

Adjustable mounting position

Open system, low profile design

Also for high accelerations
(due to low weight)

Specially developed for robots with small to medium cable and hose filling, the igus® triflex® RSE retraction system offers a way to prevent loop formation in the workspace of the robot, even in highly dynamic applications.

- For series TRC-TRE sizes 40 and 50mm
- Extremely fast response, even in highly dynamic robot programs
- Low weight, very little reduction in robot handling capacity
- Universal adjustable installation brackets
- Maintenance and lubrication-free igus® drylin® W linear unit
- For maximum degrees of freedom
- For cable diameters up to .74" (18.8mm)

Optional accessories - RSE Wheel Retraction System



Adapter brackets for
customized mounting options



Mounting brackets - for
installing directly on the tool



Clamps - axis 6 - for triflex® R
mounting bracket



Cover - for additional mounting
space and complex movements

triflex® R - triflex® RSE Wheel - Application example
For Series TRC / TRE
RSE - **(R)**etraction **(S)**ystem **(E)**lastic



triflex®
RSE



Even in confined space - reliable and defined energy supply system



triflex® R is guided closely to the arm with a low profile

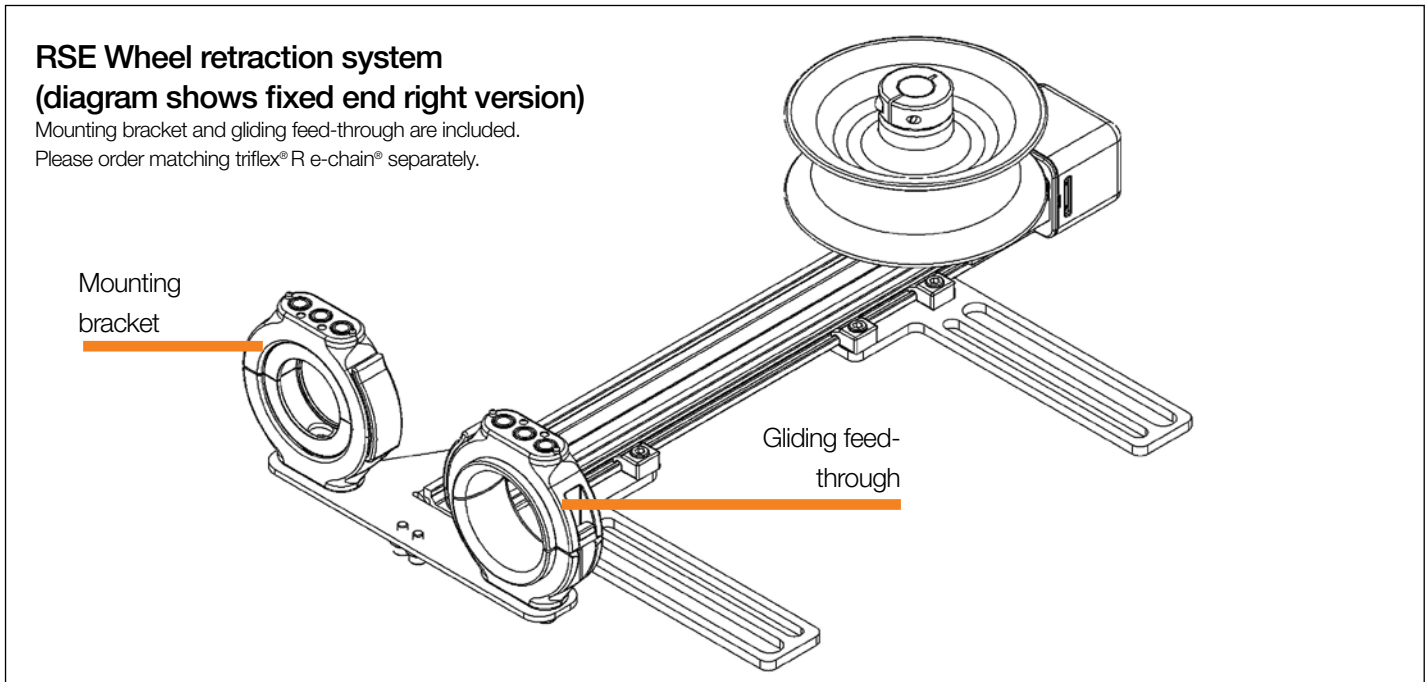
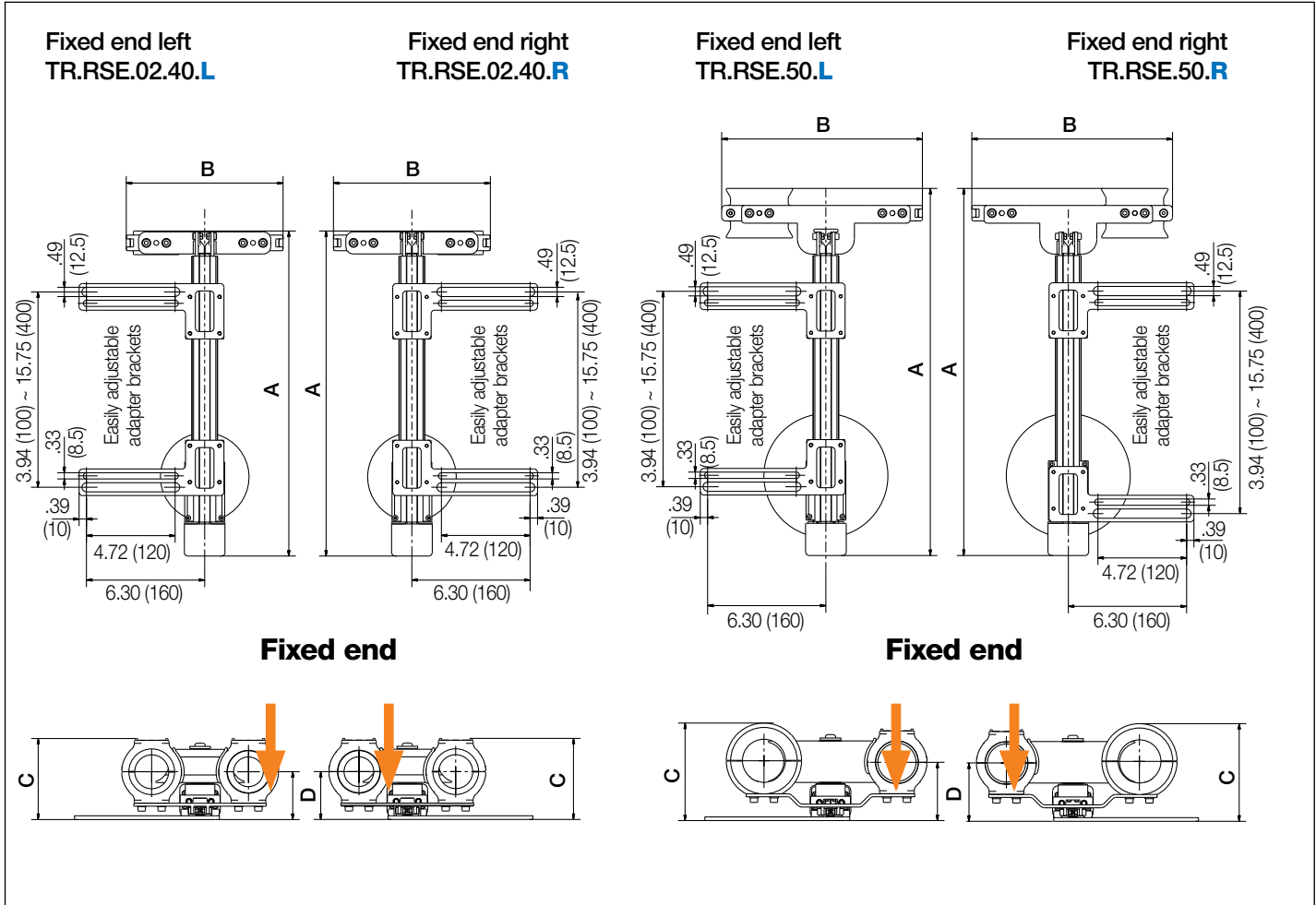

Product range for RSE

triflex® RSE - Fastening point, right			Retraction Length ¹⁾											
ø	Part No. For Series TRC		A		B		C		D		Weight			
			≤ in.	≤ (mm)	in.	(mm)	in.	(mm)	in.	(mm)	in.	(mm)	lb	(kg)
40.	TR.RSE.40.R	▶	19.69	(500)	17.32	(440)	8.66	(220)	4.33	(110)	2.55	(64.7)	3.53	(1.6)
50.	TR.RSE.50.R	▶	19.69	(500)	19.57	(497)	10.83	(275)	5.20	(132)	3.11	(79)	4.63	(2.1)
triflex® RS - Fastening point, left			Retraction Length ¹⁾											
ø	Part No. For Series TRC		A		B		C		D		Weight			
			≤ in.	≤ (mm)	in.	(mm)	in.	(mm)	in.	(mm)	in.	(mm)	lb	(kg)
40.	TR.RSE.40.L	▶	19.69	(500)	17.32	(440)	8.66	(220)	4.33	(110)	2.55	(64.7)	3.53	(1.6)
50.	TR.RSE.50.L	▶	19.69	(500)	19.57	(497)	10.83	(275)	5.20	(132)	3.11	(79)	4.63	(2.1)
Optional cover			Retraction Length ¹⁾											
ø	Part No. For Series TRC		A		B		C		D		Weight			
			≤ in.	≤ (mm)	in.	(mm)	in.	(mm)	in.	(mm)	in.	(mm)	lb	(kg)
40.	TR.RSE.40.COV	▶	19.69	(500)	17.32	(440)	8.66	(220)	4.33	(110)	2.55	(64.7)	3.53	(1.6)
50.	TR.RSE.50.COV	▶	19.69	(500)	19.57	(497)	10.83	(275)	5.20	(132)	3.11	(79)	4.63	(2.1)

1) These are the maximum values. In normal operation a filling of no more than 70% is advised.

Please order matching triflex® R e-chain® separately.

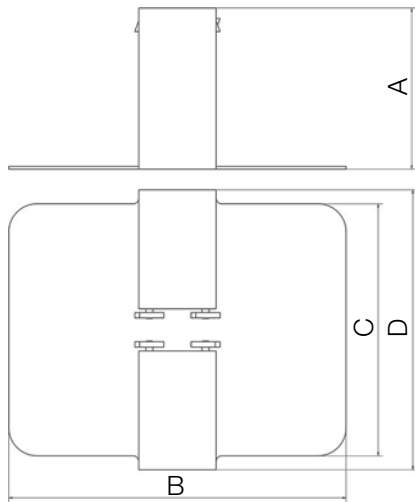

Standard chain length
found in chart below



Additional length from guide through bracket
to end of arm tool.

IMPORTANT - Ball end of
triflex® must run in direction of
the end of arm tool

RSE system (e-chain® not included)
+ Mounting bracket
+ Feed-through guide =
TR-RSE-40-L or **TR-RSE-40-R**

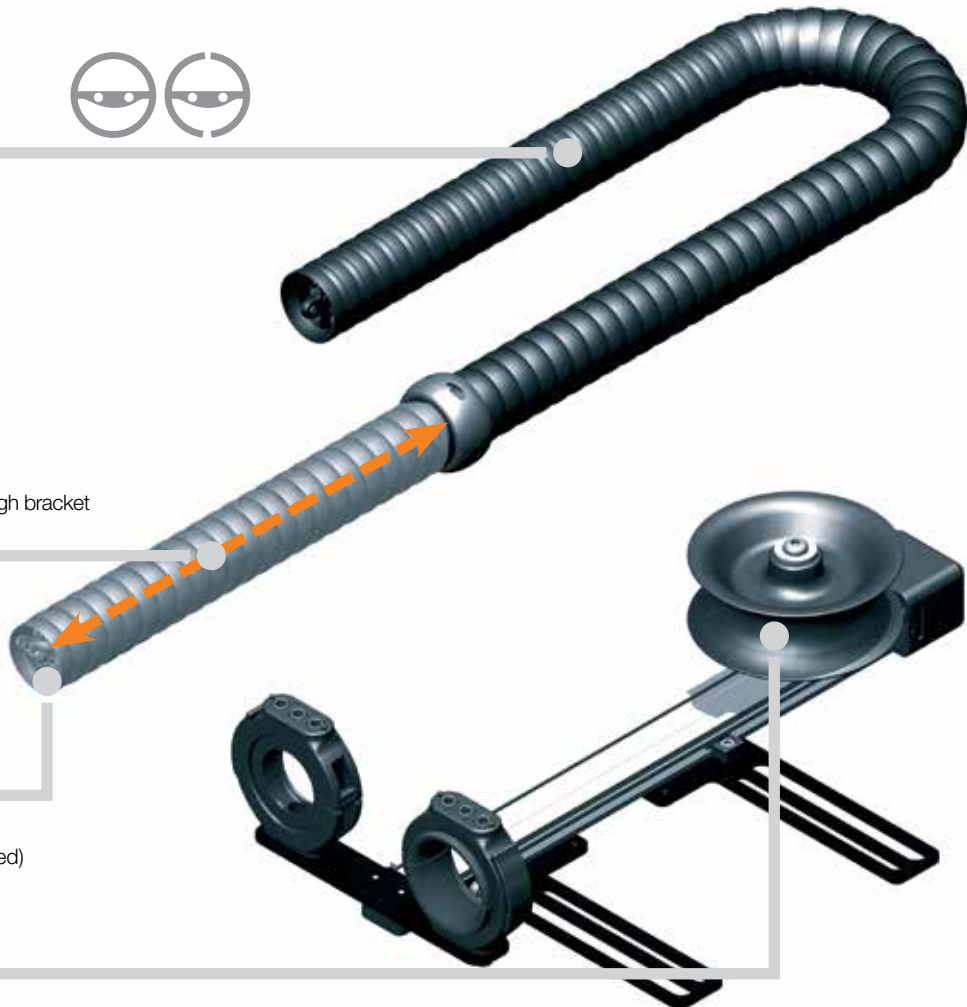

Sample order of a complete TR.RSE system, Ø Index 40, fixed end on the left,
including cover and e-chain® (standard length: 500mm)

System	Insert Ø index XX / select fixed end .L / .R	TR.RSE.40.L
+ e-chain®	Standard Length TRE-40-058-0-B x 904mm + Additional Length TRE-40-058-0-B x 1500mm = 2404mm	
+ protector		TR.40.30
+ cover:	Optional	TR.RSE.40.COV

Calculating the overall chain length - RSE e-chains®

ø Index	Bend radius <i>R</i>		e-chain® length*		Number of e-chains® links	Total e-chain® length (mm)
	in.	<i>R</i> (mm)	in.	(mm)		
40. ▶	2.28	(058)	35.59	(904)	65	LLLL + 904
50. ▶	3.15	(080)	41.10	(1044)	60	LLLL + 1044

*Values are related to the e-chain® length within the system

Please add the e-chain® length within the system to the standard length **LLLL** (measured from the gliding feed-through) to get the **overall chain length**

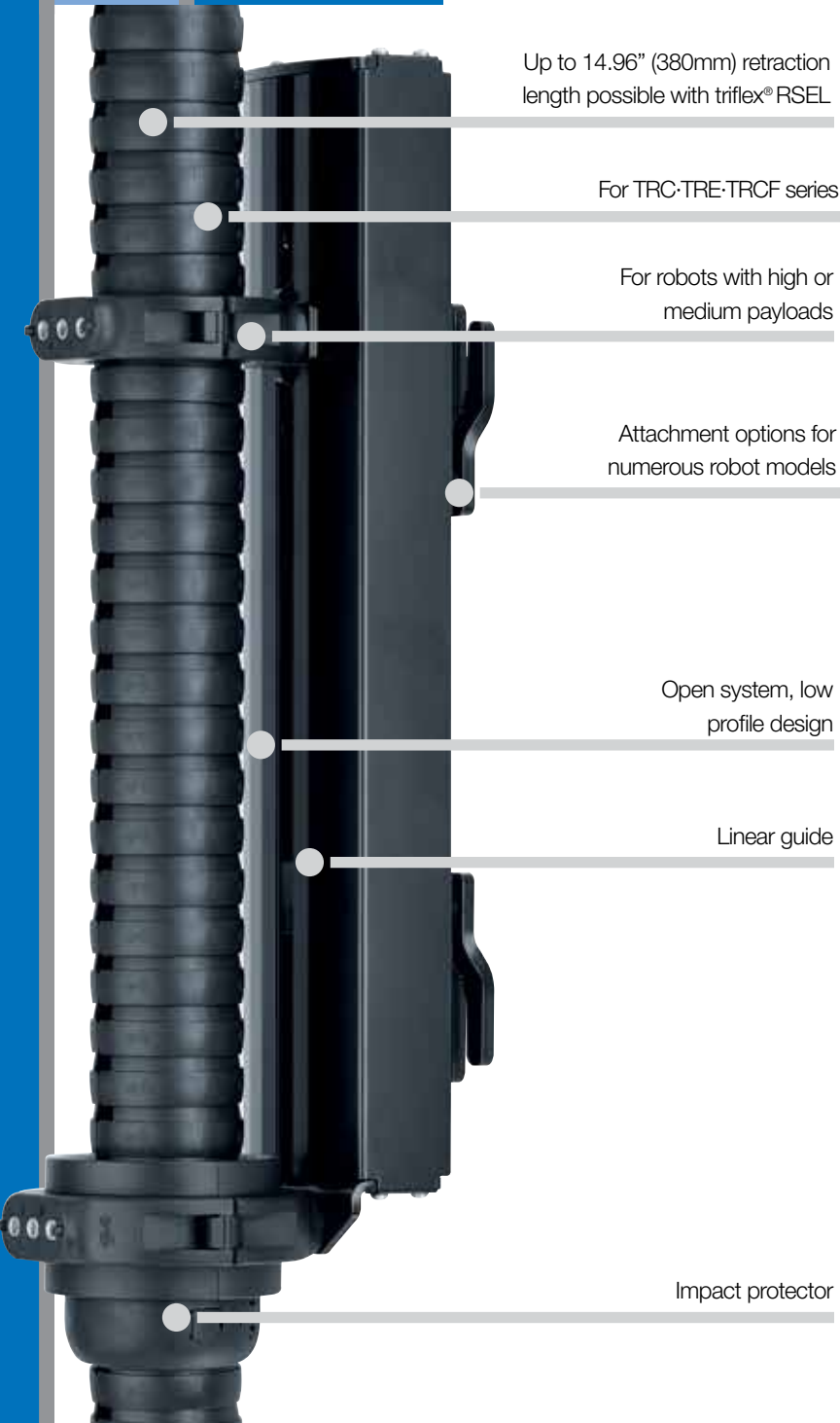

Up to 14.96" (380mm) retraction length possible with triflex® RSEL

For TRC·TRE·TRCF series

For robots with high or medium payloads

Attachment options for numerous robot models

Open system, low profile design

Linear guide

Impact protector

triflex® RSEL linear retraction system

Avoid looping on the robot head - even more cost-effective and even for corrugated tubes, with the RSEL retraction system. Especially designed for robots with medium to high payload, the igus® triflex® RSEL retraction system offers an option to actively avoid looping in the working area of the robot by keeping the e-chain® as close as possible to the robot arm.

- Cost-optimized retraction system, easy to retrofit
- Due to its standard dimensions and the very compact design, the RSEL retraction system can be mounted directly on the 3rd axis of all common types of robots
- Retraction element with elastomer band
- Prevents the e-chain® from looping or blocking the motion, even in highly dynamic applications
- Short type
- Attachment options for numerous robot models
- For robots with high and medium payloads
- The fixed end of the e-chain® can be freely selected due to the linear design of the RSE retraction system

Optional accessories - RSEL Linear retraction system



Adapter brackets for customized mounting options



Clamps - axis 6 - for triflex® R mounting bracket

triflex® R - RSEL - Application example
For Series TRC / TRE / TRCF
RSEL - **(R)**etraction **(S)**ystem **(E)**lastic **(L)**ow-cost



triflex®
RSEL



triflex® RSEL - cost-effective and space-saving
guidance of the e-chain®

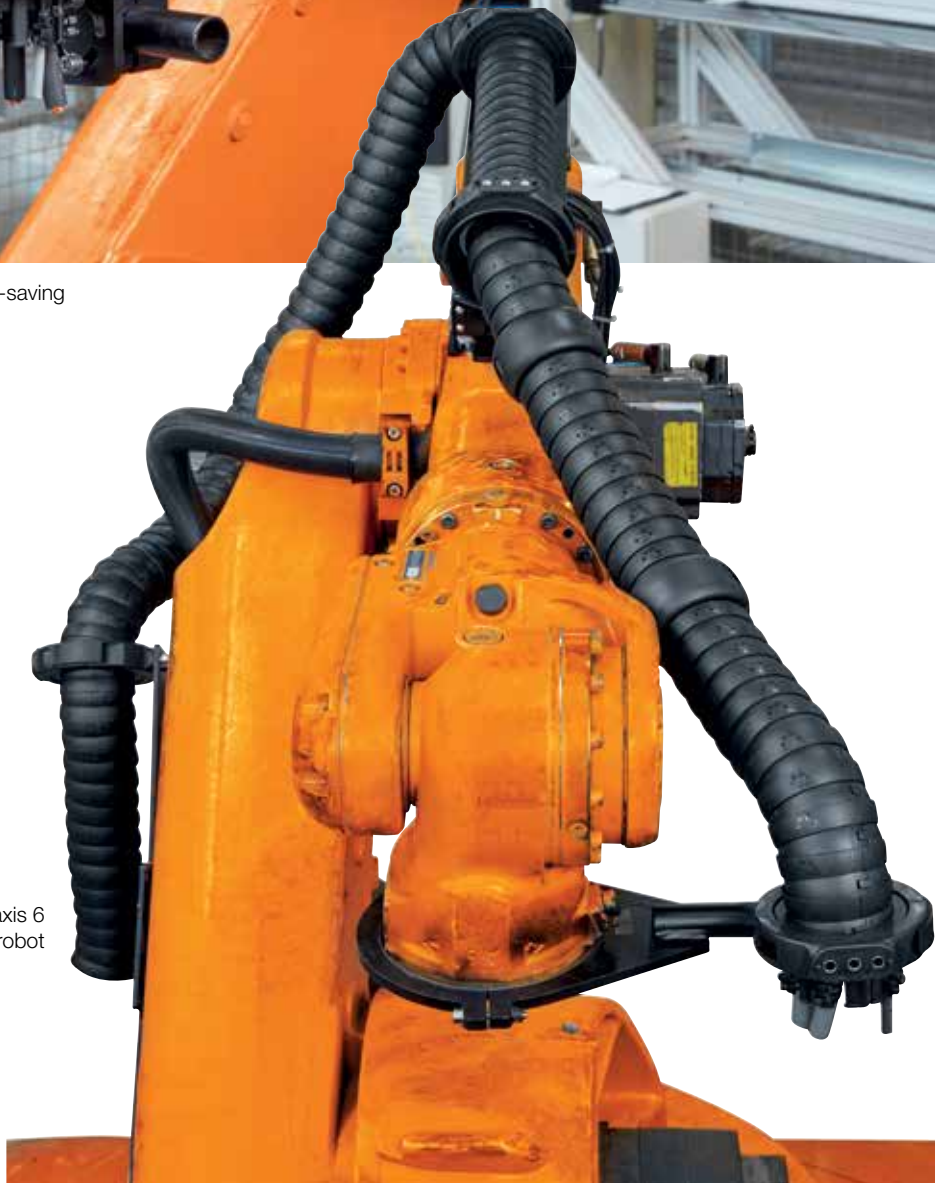

Cable routing from axis 2 to axis 6
on a robot

Matching triflex® R e-chains® for RSEL

- TRC .XX.R.0
- TRE .XX.R.0.B
- TRCF.XX.R.0



Overall e-chain® length* =
Excess length in direction **A1** +
Dimension **A** +
Excess length in direction **A6**

Limit protector

IMPORTANT - Ball end of triflex® must run in direction of the end of arm tool

RSEL system
(without e-chain®) +
mounting bracket +
gliding feed-through =
TR.RSEL.XX

*For calculation of the overall e-chain® length: Please add the desired excess length in direction **A1** and the excess length in direction **A6** and the dimension **A**.

Complete retraction system RSEL and triflex® R e-chain® TRC series. Mounting bracket and gliding feed-through are included. Please order triflex® R e-chains®, limiting protectors separately!

triflex® R - RSEL
 For Series TRC / TRE / TRCF
 Order examples for retraction system including e-chain®



triflex®
 RSEL

 Sample order of a complete TR.RSEL system,
 Ø index 85, and e-chain® (length: 2m)

System	Select Ø index	TR.RSEL.85
+ e-chain®	Insert Ø index / Insert bend radius <i>R</i> / Insert standard length in meters	6.56ft (2m) TRCF.85.135.0
+ protector	Select protector option / specify Ø index	TR.85.30
Order text:	TR.RSEL.85. + 6.56ft (2 m) TRCF.85.135.0 + TR.85.30	

 Order key
 retraction system

TR.RSEL.85



 Order key
 e-chains®

TRC .85.135.0
 TRE .85.135.0.B
 TRCF.85.135.0



More optional accessories - RSEL retraction system



Protectors
 with screw connections
 or quick release



Adapter brackets
 For custom
 mounting options



Axis 6 clamp
 For triflex® R mounting
 brackets



Product range - RSEL retraction system

ø Index	Part Number RSEL	Retraction length ¹⁾		A		B		C		Weight	
		≤ in.	≤ [mm]	in.	(mm)	in.	(mm)	in.	(mm)	lbs	(kg)
70.	▶ TR.RSEL.70	14.96	(380)	24.84	(631)	6.10	(155)	10.59	(239)	19.4	(8.8)
85.	▶ TR.RSEL.85	14.96	(380)	25.12	(638)	6.10	(155)	9.88	(251)	19.6	(8.9)

Please order matching triflex® R e-chain® separately. 1) Maximum retraction length

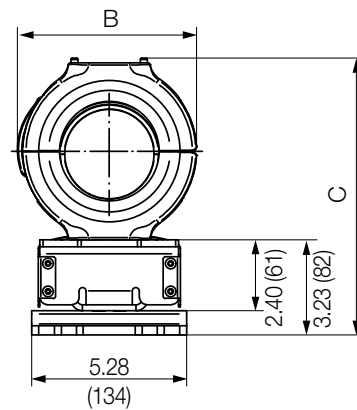
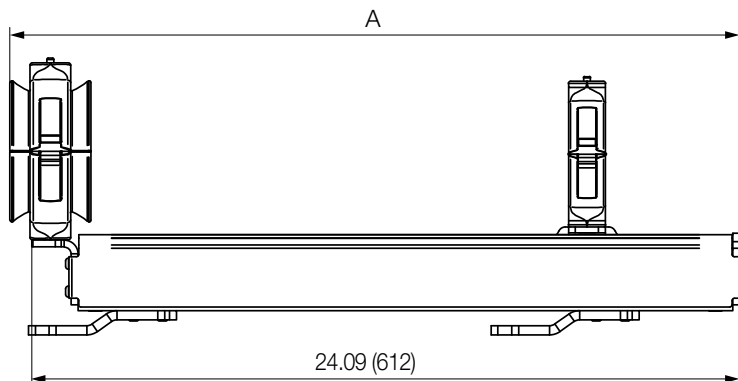

Installation height RSEL
Series TR.RSEL.70 - TR.RSEL.85

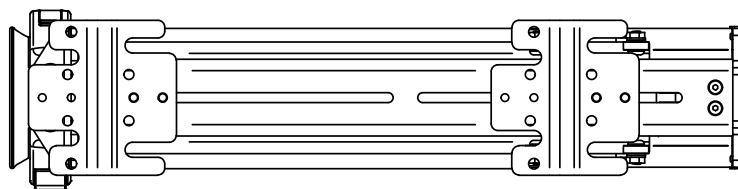

Gliding feed-through

Mounting bracket



RSEL retraction system

Mounting bracket and gliding feed-through are included.
Please order matching triflex® R e-chain® separately.



Product range - Matching e-chains® for RSEL

∅ Index	Part No. TRC enclosed	Part No. TRE "easy" design	Part No. TRCF with snap lock mechanism
70.	▶ TRC.70.110.0	TRE.70.110.B	–
85.	▶ TRC.85.135.0	TRE.85.135.B	TRCF.85.135.0

1) Available for B- and C-versions

Please note that all triflex® R e-chains can be lengthened and shortened individually and can be customized to meet the needs of your application.

Please order e-chains® as piece parts and purchase a protector for each one.

Product range - Matching protectors for RSEL

∅	① Part No. protector with screw fastener	② Part No. protector with quick-lock fastener	General image protector options
70.	▶ TR.70.10	TR.70.30	
85.	▶ TR.85.10	TR.85.30	

*Available upon request. Please consult igus® for delivery time.

Please order protectors with screw connections or quick release as limit protectors.

More information
 on protectors page X.XX

∅ Index	Bend radius <i>R</i>		Dimension <i>A</i>		General image overall e-chain® length
	in.	(mm)	in.	(mm)	
70.	▶ 4.33	(110)	20.87	(530)	
85.	▶ 5.31	(135)	20.87	(530)	

Dimension *A*

Direction *A6*
 excess length

Direction *A1*
 excess length

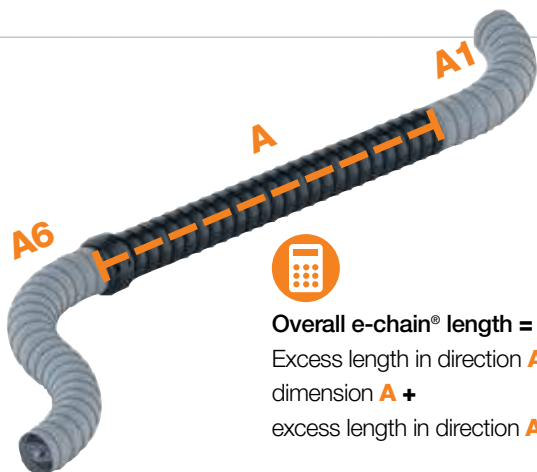

Overall e-chain® length =
 Excess length in direction *A6* +
 dimension *A* +
 excess length in direction *A1*

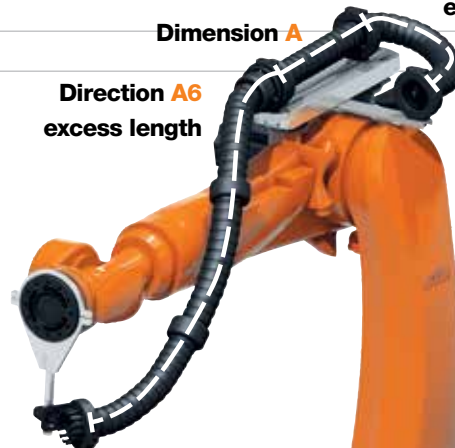

For calculation of the overall e-chain® length: Please add the desired excess length in direction *A1* and the excess length in direction *A6* and the dimension *A*. Additionally, at least 1 limit protector must be ordered.

Compensates relative motion of the integrated fiber rods
with five rigidly connected chain links

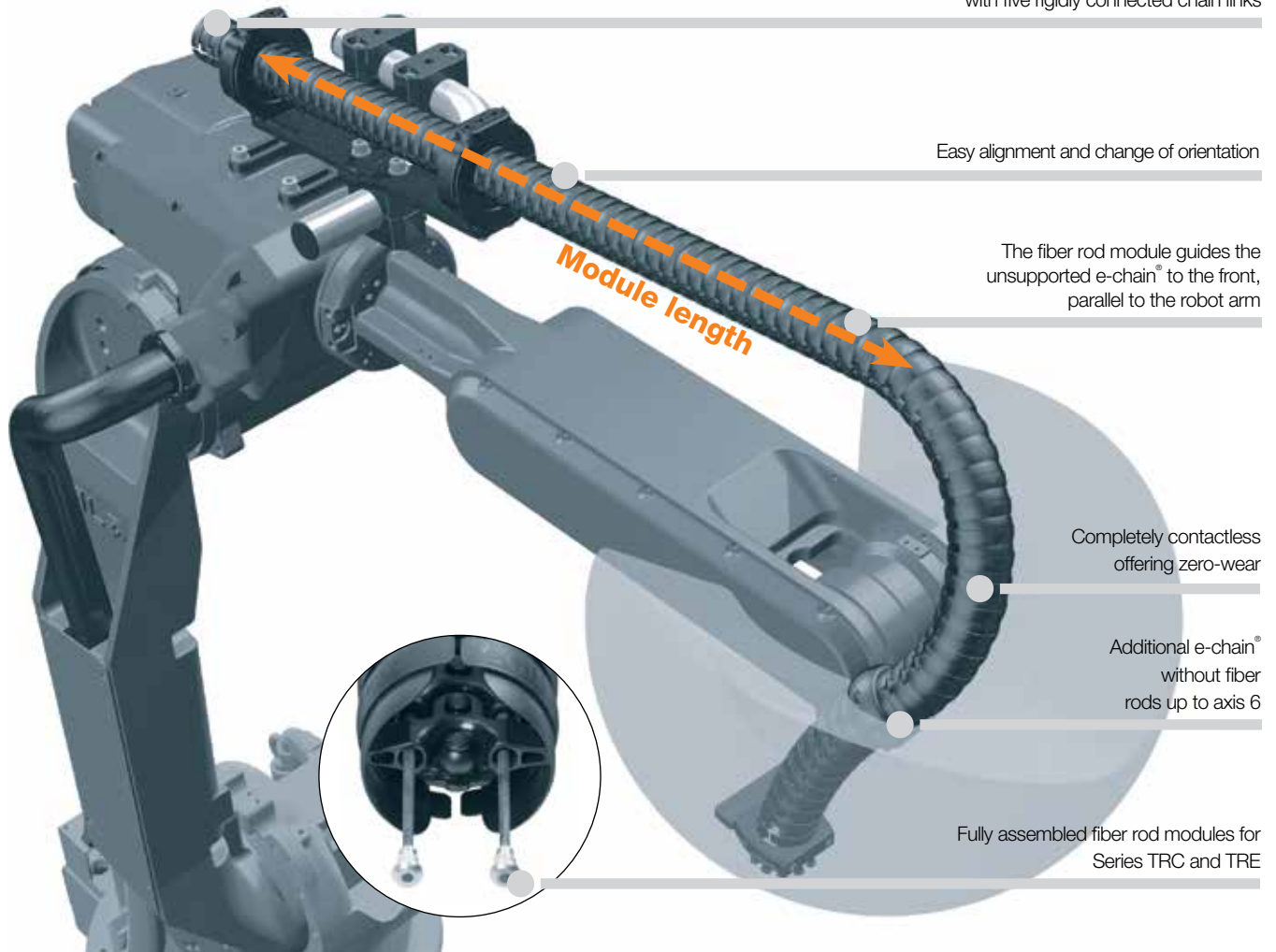

Fiber rod modules for a directional camber of the e-chain® - for TRC & TRE

We supply fully assembled fiber rod modules for triflex® R e-chain® Series TRC and TRE. The integrated fiber rods generate a directional camber of the e-chain®. This system creates a unique choice of combinations for the energy supply system on manual axis of industrial robots. The fiber rod module guides the unsupported e-chain® to the front, parallel to the robot arm. The bending properties of the modules depends on the installation orientation: only the front area is designed for flexible movement (accordingly, align with moving tool during assembly). The five rear chain links are rigidly connected and compensate the relative movement of the integrated fiber rods. A fully contactless and therefore zero-wear energy supply system can be realized, particularly for moderate movements with limited pivot motion of the axis. An additional e-chain® without fiber rods for the hand area needs to be ordered separately.



Part. No. fiber rod modules for TRC / TRE		Approx. length ft. (m)	
TRC-40	TRE-40		
TRC.F.40.1000.1.0	TRE.F.40.1000.1.0.B	3.28	1.0
TRC.F.40.0900.1.0	TRE.F.40.0900.1.0.B	2.95	0.9
TRC.F.40.0800.1.0*	TRE.F.40.0800.1.0.B*	2.62	0.8
TRC.F.40.0700.1.0	TRE.F.40.0700.1.0.B	2.30	0.7
TRC.F.40.0600.1.0	TRE.F.40.0600.1.0.B	1.97	0.6
TRC.F.40.0500.1.0	TRE.F.40.0500.1.0.B	1.64	0.5
TRC.F.40.0400.1.0	TRE.F.40.0400.1.0.B	1.31	0.4
TRC-50	TRE-50		
TRC.F.50.1400.1.0	TRE.F.50.1400.1.0.B	4.59	1.4
TRC.F.50.1200.1.0	TRE.F.50.1200.1.0.B	3.94	1.2
TRC.F.50.1000.1.0*	TRE.F.50.1000.1.0.B*	3.28	1.0
TRC.F.50.0800.1.0	TRE.F.50.0800.1.0.B	2.62	0.8
TRC.F.50.0600.1.0	TRE.F.50.0600.1.0.B	1.97	0.6
TRC.F.50.0400.1.0	TRE.F.05.0400.1.0.B	1.31	0.4
TRC-60	TRE-60		
TRC.F.60.1400.1.0	TRE.F.60.1400.1.0.B	4.59	1.4
TRC.F.60.1200.1.0	TRE.F.60.1200.1.0.B	3.94	1.2
TRC.F.60.1000.1.0*	TRE.F.60.1000.1.0.B*	3.28	1.0
TRC.F.60.0800.1.0	TRE.F.60.0800.1.0.B	2.62	0.8
TRC.F.60.0600.1.0	TRE.F.60.0600.1.0.B	1.97	0.6
TRC.F.60.0400.1.0	TRE.F.60.0400.1.0.B	1.31	0.4
TRC-70	TRE-70		
TRC.F.70.1800.1.0	TRE.F.70.1800.1.0.B	5.91	1.8
TRC.F.70.1600.1.0	TRE.F.70.1600.1.0.B	5.25	1.6
TRC.F.70.1400.1.0	TRE.F.70.1400.1.0.B	4.59	1.4
TRC.F.70.1200.1.0*	TRE.F.70.1200.1.0.B*	3.94	1.2
TRC.F.70.1000.1.0	TRE.F.70.1000.1.0.B	3.28	1.0
TRC.F.70.0800.1.0	TRE.F.70.0800.1.0.B	2.62	0.8

Part. No. fiber rod modules for TRC / TRE		Approx. length ft. (m)	
TRC-85	TRE-85		
TRC.F.85.2000.1.0	TRE.F.85.2000.1.0.B	6.56	2.0
TRC.F.85.1800.1.0	TRE.F.85.1800.1.0.B	5.91	1.8
TRC.F.85.1600.1.0	TRE.F.85.1600.1.0.B*	5.25	1.6
TRC.F.85.1400.1.0*	TRE.F.85.1400.1.0.B*	4.59	1.4
TRC.F.85.1200.1.0	TRE.F.85.1200.1.0.B	3.94	1.2
TRC.F.85.1000.1.0	TRE.F.85.1000.1.0.B	3.28	1.0
TRC.F.85.0800.1.0	TRE.F.85.0800.1.0.B	2.62	0.8
TRC-100	TRE-100		
TRC.F.100.2000.1.0	TRE.F.100.2000.1.0.B /C	6.56	2.0
TRC.F.100.1800.1.0	TRE.F.100.1800.1.0.B /C	5.91	1.8
TRC.F.100.1600.1.0	TRE.F.100.1600.1.0.B /C	5.25	1.6
TRC.F.100.1400.1.0*	TRE.F.100.1400.1.0.B /C*	4.59	1.4
TRC.F.100.1200.1.0	TRE.F.100.1200.1.0.B /C	3.94	1.2
TRC.F.100.1000.1.0	TRE.F.100.1000.1.0.B /C	3.28	1.0
TRC-125	TRE-125		
TRC.F.125.2000.1.0	TRE.F.125.2000.1.0	6.56	2.0
TRC.F.125.1800.1.0*	TRE.F.125.1800.1.0*	5.91	1.8
TRC.F.125.1600.1.0	TRE.F.125.1600.1.0	5.25	1.6
TRC.F.125.1400.1.0	TRE.F.125.1400.1.0	4.59	1.4
TRC.F.125.1200.1.0	TRE.F.125.1200.1.0	3.94	1.2
TRC.F.125.1000.1.0	TRE.F.125.1000.1.0	3.28	1.0

*Maximum recommended length for fiber rod modules
For the C version, please add the index .C

Universal assembly kit - for TRC, TRE

- Stainless steel angle tube with attachment brackets
- Freely positionable
- The energy supply system can be quickly and easily adapted to the new programming sequences of the robot
- With 2 mounting brackets for sizes 40 and 60 - with 3 mounting brackets starting at size 70

Product range - Universal mounting kit

For Series ø	Part No.	A		B		C		D		E		Weight	
		in.	(mm)	in.	(mm)	in.	(mm)	in.	(mm)	in.	(mm)	lb	(kg)
40- ▶	TR-40-80	2.91	(74)	1.57	(40)	.33	(8.4)	18.70	(475)	12.80	(325)	7.9	(3.6)
50- ▶	TR-50-80	2.91	(74)	1.57	(40)	.33	(8.4)	18.70	(475)	12.80	(325)	7.9	(3.6)
60- ▶	TR-60-80	2.91	(74)	1.57	(40)	.33	(8.4)	24.61	(625)	12.80	(325)	10.4	(4.7)
70- ▶	TR-70-80	2.95	(75)	3.15	(80)	.50	(12.6)	34.45	(875)	22.64	(575)	13.0	(5.9)
85- ▶	TR-85-80	2.95	(75)	3.15	(80)	.50	(12.6)	34.45	(875)	22.64	(575)	13.9	(6.3)
100- ▶	TR-100-80	2.95	(75)	3.15	(80)	.50	(12.6)	34.45	(875)	22.64	(575)	13.9	(6.3)
125- ▶	TR-125-80	2.95	(75)	3.15	(80)	.50	(12.6)	34.45	(875)	22.64	(575)	18.74	(8.5)

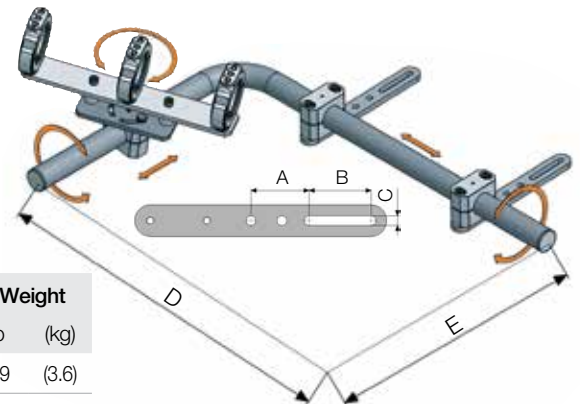

Adjustment unit for RSP and RS retraction systems

The optionally available adjustment unit is installed between the robot arm and the retraction system, and supports accurate adjustments of the assembly position of our igus® retraction systems on the robot arm. Particularly recommended when various large robots will be equipped with a uniform cable package.

Wide adjustment range
of $\pm 250\text{mm}$

Can be combined with
igus® adapter brackets

Simplifies alignment for robot
cells with restricted space

Part No. TR.907.595
weight: 11 lb.

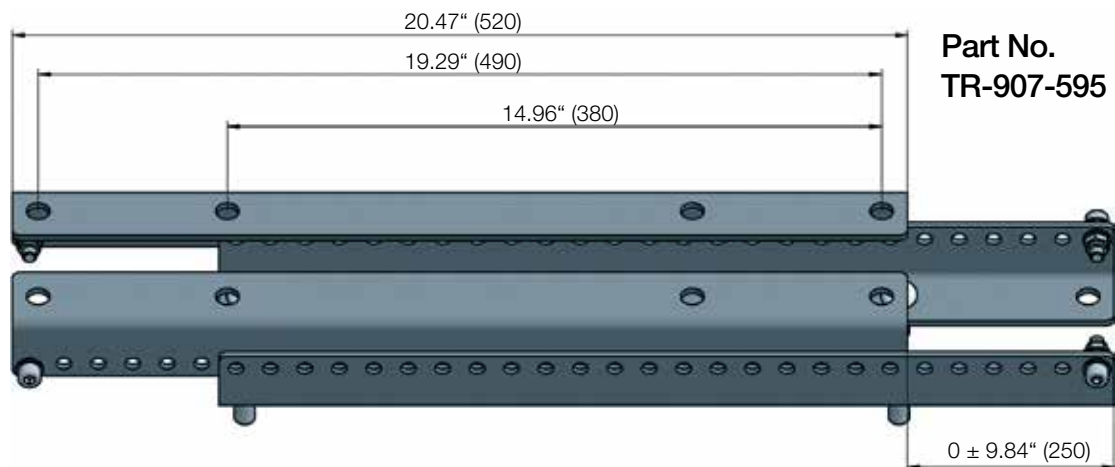
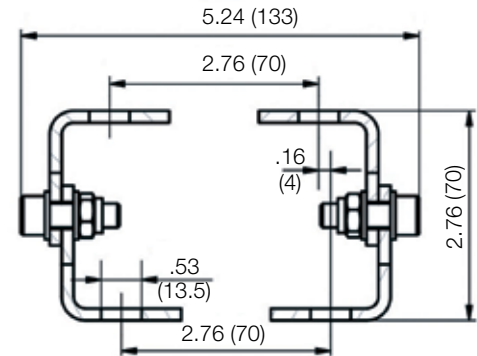
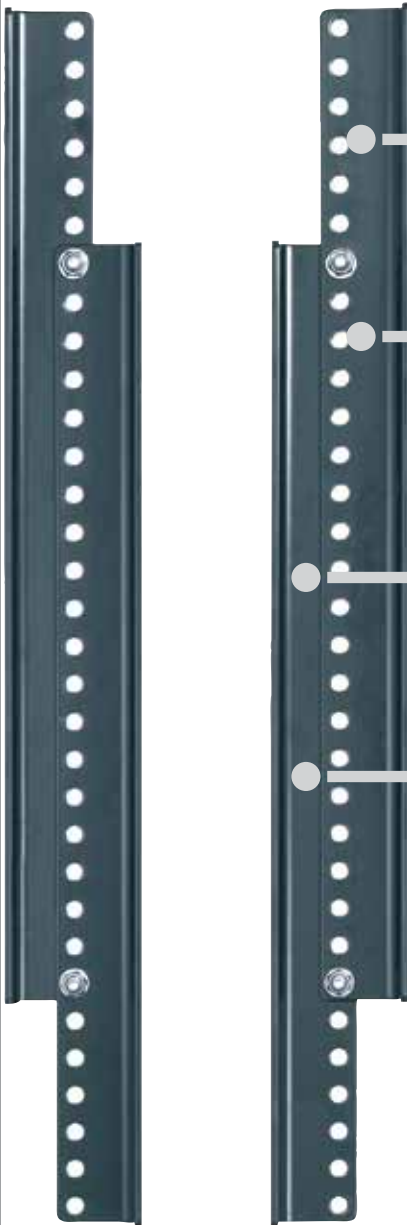

Part No.
TR-907-595

Adjustment unit to easily change the position of the retraction system

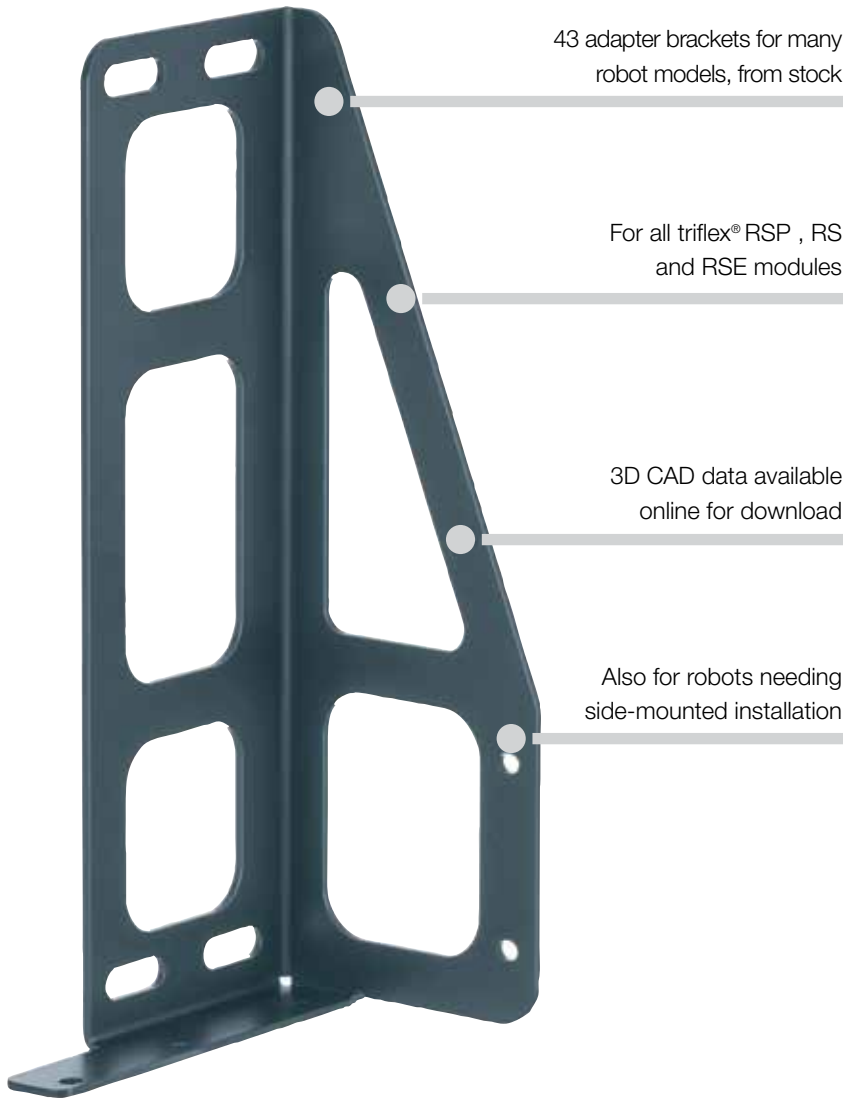

Adapter brackets for RSP, RS and RSE retraction systems

The RS and RSP retraction systems provide all widely used drill patterns for attachment: 380 x 70 mm and 490 x 90 mm (in Ø12.5 mm). We also supply a wide range of manufacturer and model-dependent adapters from stock, in order to adapt to other robot variations. For example, many robot models are equipped from the factory with only side-mounted mounting options - in these cases, our adapter product range also supports simple installation of the retraction systems without additional engineering. **Adapter brackets for many robot models, from stock.**



Application example with RS system on ABB Series 6600

Adapter bracket product range - for RSE, RS & RSP

igus®
e-chain system®

Telephone 1-800-521-2747

Internet: igus.com
email: sales@igus.com
QuickSpec: igus.com/quickspec

Adapter bracket	Part No.	For manufacturer	Example for robot type		Weight (lb)		
	TR-907-347	ABB	IRB 6600 IRB 6640 IRB 6650		8.8		
	TR-907-468	ABB	IRB 6400		21.6		
	TR-907-448	ABB	IRB 4400		11		
	TR-907-381	ABB	IRB 2400/10 IRB 2400/16		11.5		
	TR-907-905	ABB	IRB 6620		6.2		
	TR-908-494	ABB	IRB 4600 IRB 2600		6.4		
	TR-907-374	Comau	NH1 130-2.6 NH3 165-2.7 NH3 220-2.7	NJ 110-3.0 NJ 110-2.6 SMART5 NJ 165 3.0	10.4		
	TR-907-447	Comau	NM 45-2.0 NM 16-3.1		7.5		
	TR-908-493	Comau	Smart six		4.9		
	TR-907-327	Motomann	UP 20 UP 50 UP 130	UP 165 ES 165 ES 200	ES 280 HP 20 HP 50	MH6 HP 165	1.9
	TR-909-641	Motomann	MH50		4.4		

More adapter brackets on request. CAD data online.

From stock for many robot types

Adapter bracket	Part No.	For manufacturer	Example for robot type		Weight (lb)
	TR-911-220	Fanuc	M-710iC 50 M-710iC 70		4.4
	TR-908-973	Fanuc	M-710iB 45		2.4
	TR-907-270	Fanuc	R-2000iB R-2000iA R-1000iA	S 430 S 420	9.9
	TR-907-470-12	Fanuc	M-900iA 260L M-900iA 350		15.0
	TR-907-902-12	Fanuc	M-900iA 600		19.6
	TR-910-876	Fanuc	M900-IB700		10.1
	TR-907-599	Kuka	KR5 KR5arc	KR6 KR16	5.5
	TR-908-113	Kuka	KR-1000		11.5
	TR-908-014	Kuka	KR 60 (HA) KR 30 (HA)		9.5
	TR-907-706	Reis	RV30-26 RV10-16 RV20-16 RV60-16	RV60-26 RV60-40 RV60-60 RV130	9.5
	Spacer pin TR-911-223	Kuka Series	Series Quantec (4 piece kit)		1.3

PDF: igus.com/e-chain-pdfs
Product information: igus.com/e-chains



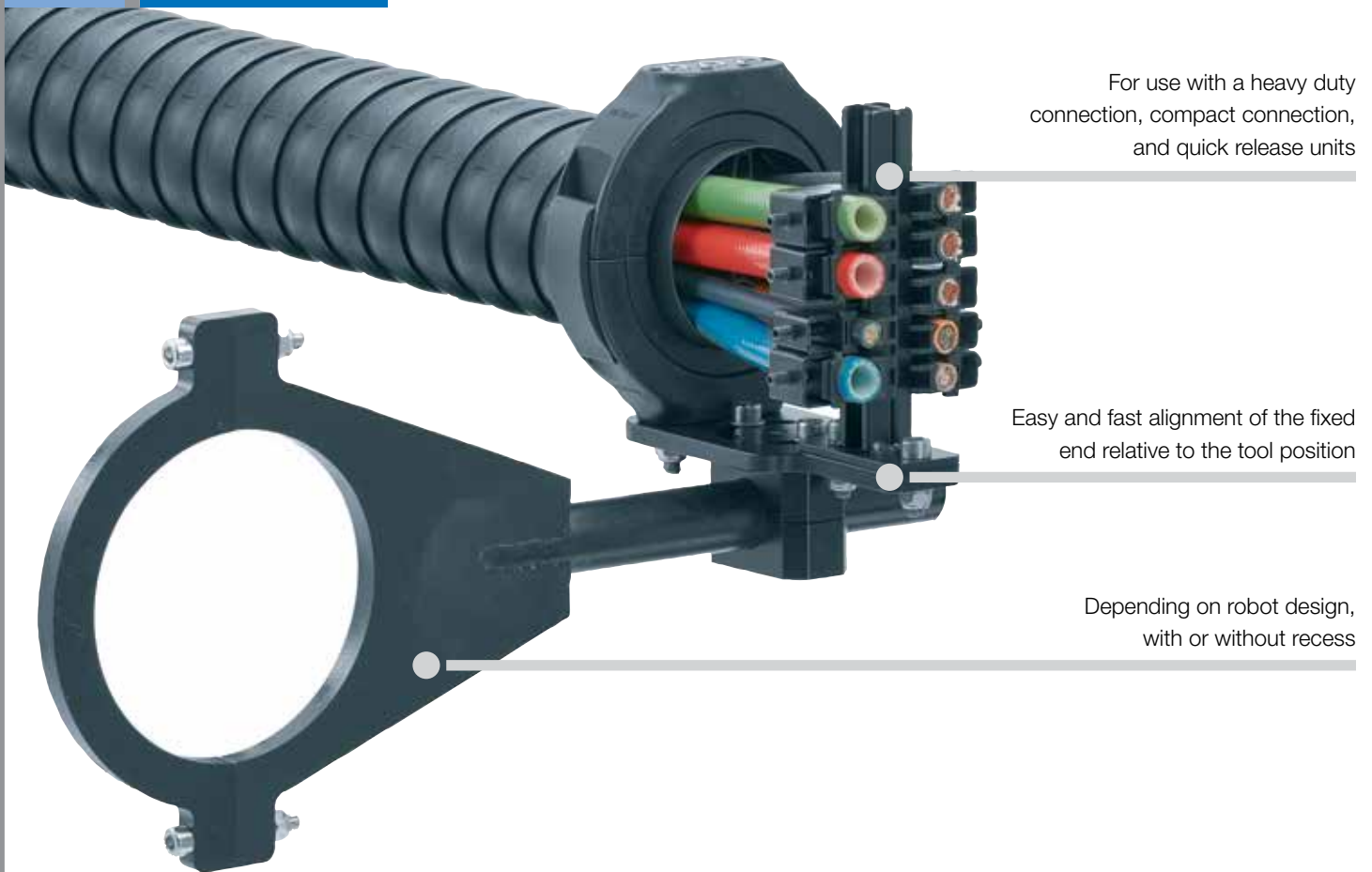

For use with a heavy duty connection, compact connection, and quick release units

Easy and fast alignment of the fixed end relative to the tool position

Depending on robot design, with or without recess

Clamps for attachment to axis 6

The clamp is used to attach a mounting bracket to axis 6, with a bar (Ø 30mm) for all robots. They are easy and quick to assemble.

- For use with heavy duty connection TR.XX.20 / TR.XX.23
- For use with compact connection TR.XX.21.01 / TR.XX.21.02
- For use with quick exchange unit TR.XX.22

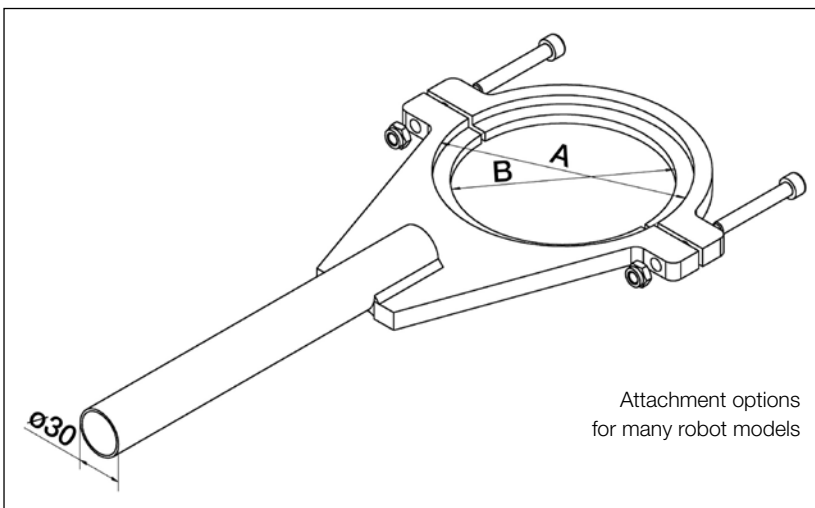

Attachment options
for many robot models



triflex® R - Accessories
triflex® RS & RSP Accessories
Axis 6 clamps - Product range



triflex®
R

Part No.	Example for robot type	Flange	Dim. A		Dim. B		Weight (lb)
			in.	(mm)	in.	(mm)	
TR-907-857	KUKA KR 30-3 (HA)	yes	5.12	(130)	4.53	(115)	4.2
	KUKA KR 60-3 (HA)	yes	5.12	(130)	4.53	(115)	4.2
	KUKA KR 60 L45-3 (HA)	yes	5.12	(130)	4.53	(115)	4.2
	KUKA KR 60 L30-3 (HA)	yes	5.12	(130)	4.53	(115)	4.2
TR-907-901	KUKA Quantec, large flange	yes	8.07	(205)	7.48	(190)	5.5
	KUKA KR 125/3	yes	8.07	(205)	7.48	(190)	5.5
	KUKA KR 150/3	yes	8.07	(205)	7.48	(190)	5.5
	KUKA KR 200/3	yes	8.07	(205)	7.48	(190)	5.5
	KUKA KR 360/1	yes	8.07	(205)	7.48	(190)	5.5
	KUKA KR 500/1	yes	8.07	(205)	7.48	(190)	5.5
	KUKA KR 150/2 Series 2000	yes	8.07	(205)	7.48	(190)	5.5
	KUKA KR 180/2 Series 2000	yes	8.07	(205)	7.48	(190)	5.5
	KUKA KR 210/2 Series 2000	yes	8.07	(205)	7.48	(190)	5.5
TR-908-115	KUKA KR 1000 Titan	yes	9.84	(250)	9.53	(242)	6.7
TR-907-992	Fanuc R-2000iB	yes	6.50	(165)	6.30	(160)	5.3
	Fanuc R-2000iA	yes	6.50	(165)	6.30	(160)	5.3
	Reis RV 130	yes	6.50	(165)	6.30	(160)	5.3
TR-908-065	Fanuc M-710iC 50	yes	5.12	(130)	4.88	(124)	4.9
	Fanuc M-710iC 70	yes	5.12	(130)	4.88	(124)	4.9
TR-909-387	Motoman UP 50	yes	4.92	(125)	3.94	(100)	4.2
	Motoman HP 50	yes	4.92	(125)	3.94	(100)	4.2
	Motoman MH 50	yes	4.92	(125)	3.94	(100)	4.2
TR-910-544	Reis RV60-60	yes	5.71	(145)	4.92	(125)	4.2
	Reis RV60-40	yes	5.71	(145)	4.92	(125)	4.2
	Fanuc R-1000	yes	5.71	(145)	4.92	(125)	4.2
TR-908-347	Stäubli TX200	yes	5.71	(145)	4.92	(125)	4.2
TR-907-667-125	for custom flange	no	4.92	(125)	= A	= A	4.6
TR-907-667-140	KUKA Quantec small flange	no	5.51	(140)	= A	= A	10.8
TR-907-667-142	Hyundai HX 165	no	5.59	(142)	= A	= A	5.0
TR-907-667-150	Comau NJ 130	no	5.91	(150)	= A	= A	5.3
TR-907-667-160	ABB IRB 6400	no	6.30	(160)	= A	= A	5.4
	Fanuc S420	no	6.30	(160)	= A	= A	5.4
TR-907-667-180	for custom flange	no	7.09	(180)	= A	= A	5.6
TR-907-667-190	Comau NH3	no	7.48	(190)	= A	= A	5.7
TR-907-667-200	KUKA KR 125/1	no	7.87	(200)	= A	= A	6.0
	KUKA KR 150/1	no	7.87	(200)	= A	= A	6.0
	KUKA KR 200/1	no	7.87	(200)	= A	= A	6.0
	ABB IRB 6640	no	7.87	(200)	= A	= A	6.0
	ABB IRB 6620	no	7.87	(200)	= A	= A	6.0
	ABB IRB 6650	no	7.87	(200)	= A	= A	6.0
TR-907-667-220	KUKA KR 360-2	no	8.66	(220)	= A	= A	6.2
	KUKA KR 500-2	no	8.66	(220)	= A	= A	6.2
	KUKA KR 360-3	no	8.66	(220)	= A	= A	6.2
	KUKA KR 500-3	no	8.66	(220)	= A	= A	6.2
TR-907-667-223	ABB IRB 7600-340	no	8.78	(223)	= A	= A	7.7
	ABB IRB 7600-500	no	8.78	(223)	= A	= A	7.7
TR-907-667-250	Fanuc M900iA 350	no	9.84	(250)	= A	= A	7.1
	Fanuc M900iA 260L	no	9.84	(250)	= A	= A	7.1
TR-907-667-275	Fanuc M900iA 200P	no	10.83	(275)	= A	= A	7.5
TR-907-667-315	Fanuc M900iA 600	no	12.40	(315)	= A	= A	7.9
	Fanuc M900iA 400L	no	12.40	(315)	= A	= A	7.9

Other sizes available on request!



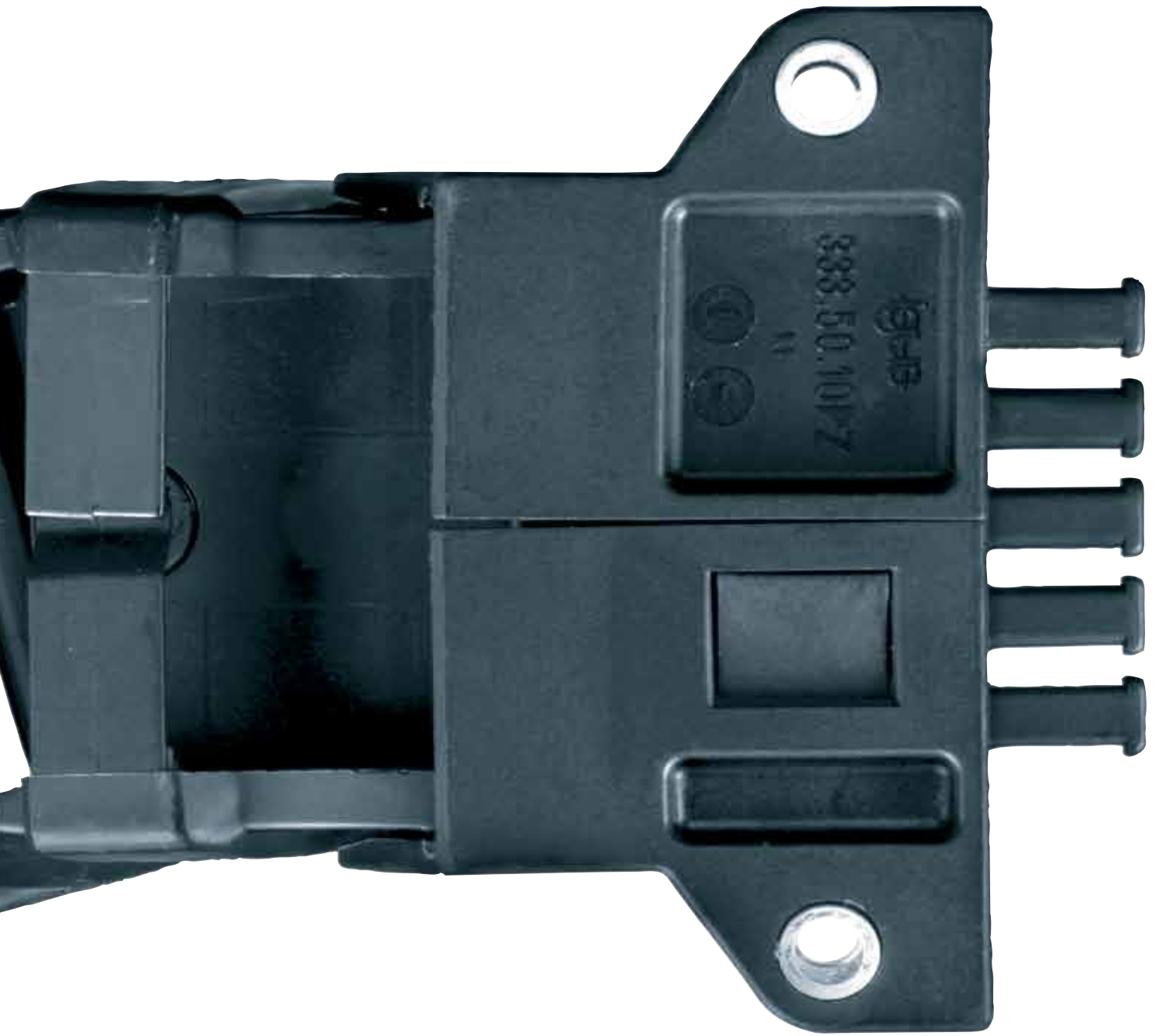

igus[®]
E-Z triflex[®]

E-Z triflex® - for 2D and 3D movements, easy access to cable from both sides

The triflex® series has been developed to safely guide cables through a 3D movement. With E-Z triflex®, the installation of cables and hoses is easy. Cables can be inserted into the e-chain® from the top or bottom through an opening along the length of the chain. The unique modular design of triflex® enables very complex movements through all three axes.

Typical industries and applications

- Machine Tools
- Robots
- Material handling
- Plastics machinery
- Construction machines
- Vehicles
- General machinery
- Medical equipment



iF-Design awards for
Easy triflex®-design



Torsional motion
possible



UL94-V2
classifications



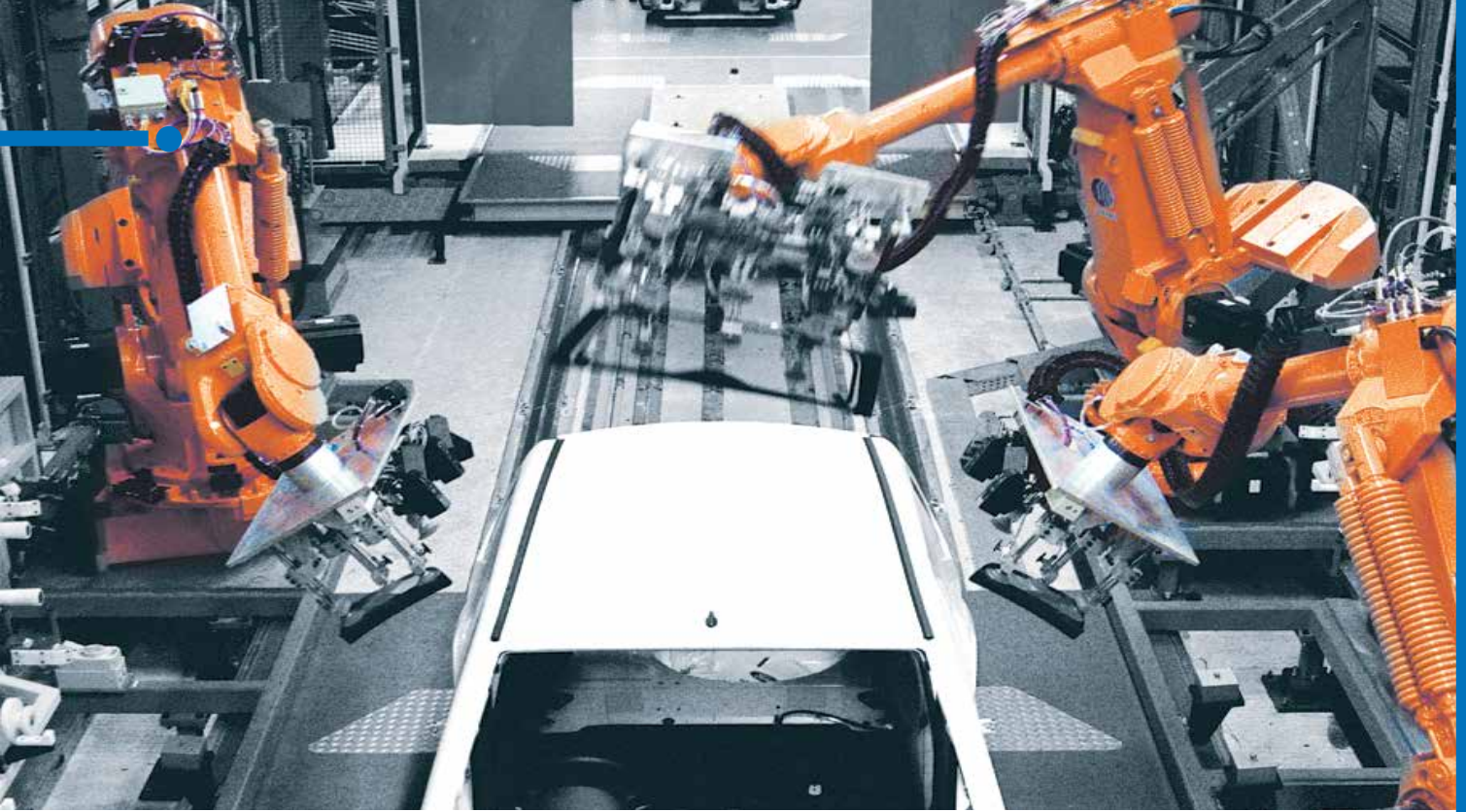

Robots with igus® E-Z triflex® e-chains® on an assembly line



E-Z triflex® e-chains® for multi-dimensional movements on a production line



E-Z triflex® e-chains® also for easy applications - here an aesthetic application

E-Z triflex® - The Solution for Your Office

Dangling lines are risky and unaesthetic. The new solution: E-Z triflex® and triflex® e-chains® with special connector elements for your desk. They offer reliable, movable and elegant protection for lines, are quickly installed and are available in many variations. Naturally they can be installed at any time as retrofits. Simply press the lines from two sides. This is possible at any point desired.

e-chain system® E-Z triflex® Series

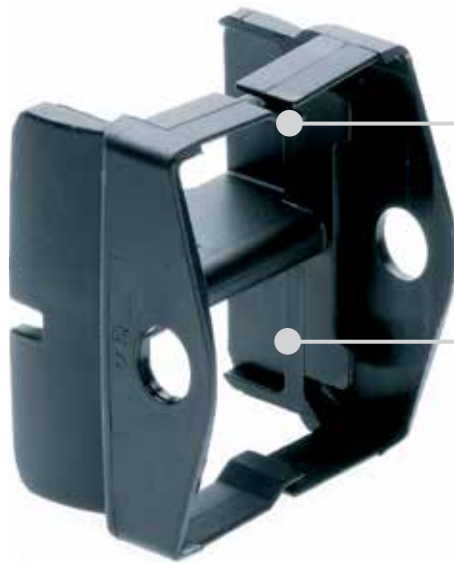

E-Z Chain®
design -
simply press
cables in

Material
igumid NB -
UL94-V2
classification

Select this modular e-chain system® for:

- 3-axis motions in all kinds of machinery
- Some robotics applications
- Very fast cable assembly with “E-Z” design
- Simple filling from two sides
- Where rectangular shapes fit better
- Combination of different bending radii and movement directions
- Lengthen and shorten anywhere
- KMA mounting brackets with integrated strain relief
- You can find more technical data about the material, chemical resistance, temperatures ► **Design, Chapter 1**

Selection table

Single-axis and double-axis movement:

Series	Inner Height		Inner Width		Outer height/Outer Width		Bending Radii	
	<i>Bi 1/Bi 2</i>		<i>Bi 3</i>		<i>Ba</i>		<i>R</i>	
	in.	(mm)	in.	(mm)	in.	(mm)	in.	(mm)
E331-25	.51	(13)	.98	(25)	1.34	(34)	1.89 - 7.87	(048 - 200)
E331-32	.69	(17.5)	1.26	(32)	1.97	(50)	2.95 - 9.84	(075 - 250)
E331-50	1.02	(26)	1.97	(50)	2.68	(68)	3.94 - 9.84	(100 - 250)
E331-75	1.52	(38.5)	2.95	(75)	3.78	(96)	5.51 - 11.81	(140 - 300)

Single-axis and double-axis movement:

Series	Inner Height		Inner Width		Outer height/Outer Width		Bending Radii	
	<i>Bi 1/Bi 2</i>		<i>Bi 3</i>		<i>Ba</i>		<i>R</i>	
	in.	(mm)	in.	(mm)	in.	(mm)	in.	(mm)
E332-25	.51	(13)	.98	(25)	1.34	(34)	1.89 - 7.87	(048 - 200)
E332-32	.69	(17.5)	1.26	(32)	1.97	(50)	2.95 - 9.84	(075 - 250)
E332-50	1.02	(26)	1.97	(50)	2.68	(68)	3.94 - 9.84	(100 - 250)
E332-75	1.52	(38.5)	2.95	(75)	3.78	(96)	5.51 - 11.81	(140 - 300)

Triple-axis movement

Series	Inner Height		Inner Width		Outer height/Outer Width		Bending Radii	
	<i>Bi 1/Bi 2</i>		<i>Bi 3</i>		<i>Ba</i>		<i>R</i>	
	in.	(mm)	in.	(mm)	in.	(mm)	in.	(mm)
E333-25	.51	(13)	.98	(25)	1.34	(34)	1.89 - 7.87	(048 - 200)
E333-32	.69	(17.5)	1.26	(32)	1.97	(50)	2.95 - 9.84	(075 - 250)
E333-50	1.02	(26)	1.97	(50)	2.68	(68)	3.94 - 9.84	(100 - 250)
E333-75	1.52	(38.5)	2.95	(75)	3.78	(96)	5.51 - 11.81	(140 - 300)



Available from stock. Orders ship as early as today.*

*On average 90% of orders ship the same day..

e-chain system® E-Z triflex® Series

E-Z triflex® Series - Assembling



1
Twist and snap in

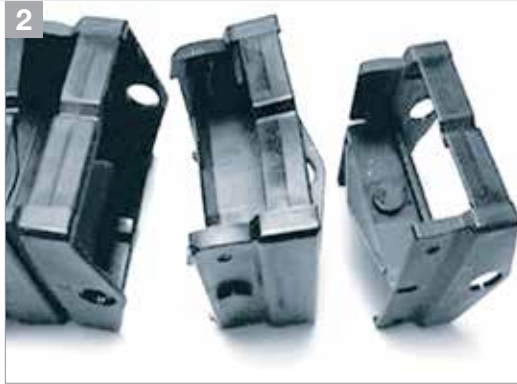

2
Shorten and lengthen
at any given point

E-Z triflex® Series - Separating



1
Lever the E-Z triflex®
side link with screwdriver



2
Twist and separate - For Series E333
you have to separate the "middle" pin

E-Z triflex® Series - Filling



1
Easy to fill - simply press cables in...



2
...and easy to take the cables out

Price Index



Flammability Class
VDE 0304 IIC UL94 V2



Torsion motion possible



iF-Design Award Winner

Assembly Tips



Easy to fill - simply press cables in



- If simple cable installation is required with complex movements
- If simple cable installation from both sides with complex movements is required
- For repair and supplementation of existing triflex® Systems



- For circular movements with high loads
 - twisterchain® System, from **Chapter 8**
- If chip protection is necessary
 - triflex® System, from **Chapter 8**

Features & Benefits

- 1 KMA split-open mounting bracket with integrated strain relief
- 2 Patented "push-button-design"
- 3 iF-Design Award Winner
- 4 Different bending radii and directions can be combined
- 5 Robotics applications possible
- 6 Shorten and lengthen at any given point
- 7 3-Axis motions in machinery of all kinds
- 8 Simple filling from 2 sides "E-Z Chain®"-design - simply press in cable along the inner radius or the outer radius

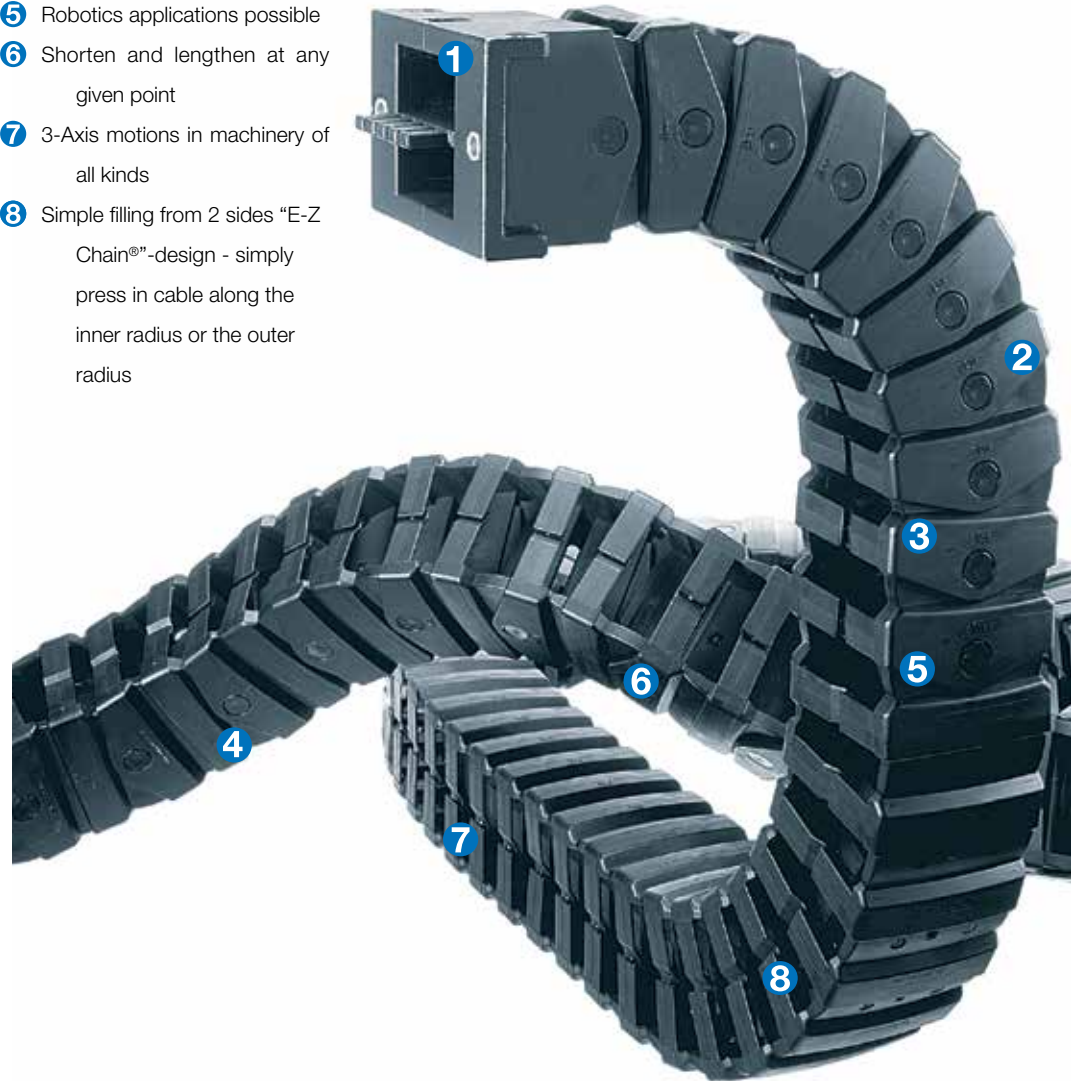

Order Example: Complete e-chain®

Please indicate chain length or number of links. Example:

6.56 ft (2 m) **E333-50-100/100-0**

e-chain®

1 Set **333-50-12PZ**

Mounting Bracket

Technical Data



Details of material properties

➤ **Chapter 1**

Material - permitted temperature

igumid NB / -40°F (-40°C) up to +176°F (+80° C)

Flammability Class, igumid NB

VDE 0304 IIC UL94 V2

Single Axis Movement, Series E331

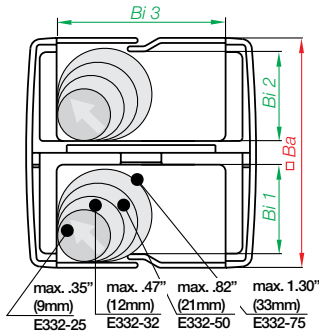

Part No. structure

E331-	50-2-	100-	0
-------	-------	------	---

- Color - black
- Bending radius
- Width
- Series

Part No.	Bi 1	Bi 2	Bi 3	Ba
E331-25-2- <input type="text"/> -0	.51 (13)	.51 (13)	.98 (25)	1.34 (34)
E331-32-2- <input type="text"/> -0	.69 (17.5)	.69 (17.5)	1.26 (32)	1.97 (50)
E331-50-2- <input type="text"/> -0	1.02 (26)	1.02 (26)	1.97 (50)	2.68 (68)
E331-75-2- <input type="text"/> -0	1.52 (38.5)	1.52 (38.5)	2.95 (75)	3.78 (96)

Supplement part number with required radius from below
for example E331-50-2--0

Installation dimensions for single-axis movement

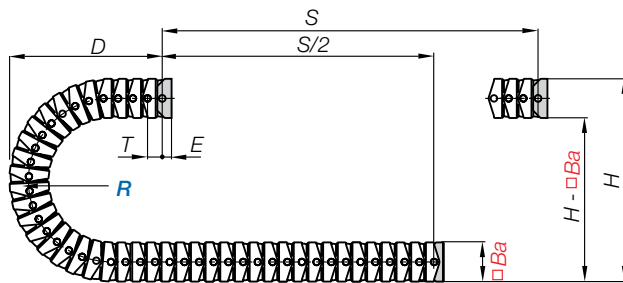

For center mount applications:
Chain length = $\frac{S}{2} + K$

Legend

- S = Length of travel
- R = Bending radius
- H = Nominal clearance height
- D = Overlength e-chain® radius in final position
- K = $\pi \cdot R +$ "safety buffer"

Series E331-25-2--0

R	1.89 (048)	2.95 (075)	3.94 (100)	4.92 (125)	5.91 (150)	6.89 (175)	7.87 (200)
H	5.12 (130)	7.28 (185)	9.25 (235)	11.22 (285)	13.19 (335)	15.15 (385)	17.13 (435)
D	3.74 (95)	4.92 (125)	5.91 (150)	6.89 (175)	7.87 (200)	8.86 (225)	9.84 (250)
K	7.68 (195)	11.02 (280)	14.17 (360)	17.32 (440)	20.28 (515)	23.43 (595)	26.57 (675)

Pitch = .57 (14.5 mm)
Links/ft (m) = 21.03 (69)
Dimensions E = .39 (10 mm)
Ba = 1.34 (34 mm)

Series E331-32-2--0

R	2.95 (075)	3.94 (100)	4.92 (125)	5.91 (150)	7.87 (200)	9.84 (250)
H	7.87 (200)	9.84 (250)	11.81 (300)	13.78 (350)	17.72 (450)	21.65 (550)
D	5.12 (130)	6.10 (155)	7.09 (180)	8.07 (205)	10.04 (255)	12.01 (305)
K	12.01 (305)	15.15 (385)	18.30 (465)	21.46 (545)	27.56 (700)	34.06 (865)

Pitch = .98 (25 mm)
Links/ft (m) = 12.24 (40)
Dimensions E = .79 (20 mm)
Ba = 1.97 (50 mm)

Series E331-50-2--0

R	3.94 (100)	4.92 (125)	5.91 (150)	7.87 (200)	9.84 (250)
H	10.63 (270)	12.60 (320)	14.76 (375)	18.50 (470)	22.44 (570)
D	7.68 (195)	8.66 (220)	9.65 (245)	11.61 (295)	13.58 (345)
K	17.13 (435)	20.47 (520)	23.23 (590)	29.53 (750)	35.83 (910)

Pitch = 1.18 (30 mm)
Links/ft (m) = 10.17 (34)
Dimensions E = .98 (25 mm)
Ba = 2.68 (68 mm)

Series E331-75-2--0

R	5.51 (140)	6.89 (175)	7.87 (200)	9.84 (250)	11.81 (300)
H	14.96 (380)	17.71 (450)	19.69 (500)	23.62 (600)	27.56 (700)
D	9.45 (240)	10.83 (275)	11.81 (300)	13.78 (350)	15.75 (400)
K	21.65 (550)	25.98 (660)	29.13 (740)	35.43 (900)	41.73 (1060)

Pitch = 1.42 (36 mm)
Links/ft (m) = 8.45 (28)
Dimensions E = .98 (25 mm)
Ba = 3.78 (96 mm)



Double Axis Movement, Series E332

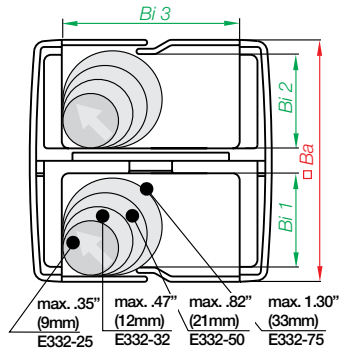

Part No. structure

E332-	75-2-	200-	0
-------	-------	------	---

- Color - black
- Bending radius
- Width
- Series

Part No.	Bi 1	Bi 2	Bi 3	Ba
E332-25-2- <input type="text"/> -0	.51 (13)	.51 (13)	.98 (25)	1.34 (34)
E332-32-2- <input type="text"/> -0	.69 (17.5)	.69 (17.5)	1.26 (32)	1.97 (50)
E332-50-2- <input type="text"/> -0	1.02 (26)	1.02 (26)	1.97 (50)	2.68 (68)
E332-75-2- <input type="text"/> -0	1.52 (38.5)	1.52 (38.5)	2.95 (75)	3.78 (96)

Supplement part number with required radius from below
for example, E332-75-2--0

Installation dimensions for double-axis movement

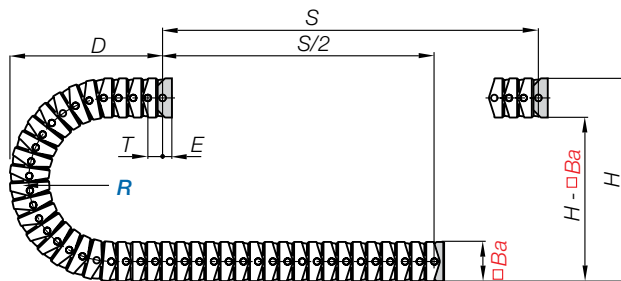

For center mount applications:
Chain length = $\frac{S}{2} + K$

Legend

- S = Length of travel
- R = Bending radius
- H = Nominal clearance height
- D = Overlength e-chain® radius in final position
- $K = \pi \cdot R + \text{"safety buffer"}$

Series E332-25-2--0

R	1.89 (048)	2.95 (075)	3.94 (100)	4.92 (125)	5.91 (150)	6.89 (175)	7.87 (200)
H	5.12 (130)	7.28 (185)	9.25 (235)	11.22 (285)	13.19 (335)	15.15 (385)	17.13 (435)
D	3.74 (95)	4.92 (125)	5.91 (150)	6.89 (175)	7.87 (200)	8.86 (225)	9.84 (250)
K	7.68 (195)	11.02 (280)	14.17 (360)	17.32 (440)	20.28 (515)	23.43 (595)	26.57 (675)

- Pitch = .57 (14.5 mm)
- Links/ft (m) = 21.03 (69)
- Dimensions E = .39 (10 mm)
- Ba = 1.34 (34 mm)

Series E332-32-2--0

R	2.95 (075)	3.94 (100)	4.92 (125)	5.91 (150)	7.87 (200)	9.84 (250)
H	7.87 (200)	9.84 (250)	11.81 (300)	13.78 (350)	17.72 (450)	21.65 (550)
D	5.12 (130)	6.10 (155)	7.09 (180)	8.07 (205)	10.04 (255)	12.01 (305)
K	12.01 (305)	15.15 (385)	18.30 (465)	21.46 (545)	27.56 (700)	34.06 (865)

- Pitch = .98 (25 mm)
- Links/ft (m) = 12.24 (40)
- Dimensions E = .79 (20 mm)
- Ba = 1.97 (50 mm)

Series E332-50-2--0

R	3.94 (100)	4.92 (125)	5.91 (150)	7.87 (200)	9.84 (250)
H	10.63 (270)	12.60 (320)	14.76 (375)	18.50 (470)	22.44 (570)
D	7.68 (195)	8.66 (220)	9.65 (245)	11.61 (295)	13.58 (345)
K	17.13 (435)	20.47 (520)	23.23 (590)	29.53 (750)	35.83 (910)

- Pitch = 1.18 (30 mm)
- Links/ft (m) = 10.17 (34)
- Dimensions E = .98 (25 mm)
- Ba = 2.68 (68 mm)

Series E332-75-2--0

R	5.51 (140)	6.89 (175)	7.87 (200)	9.84 (250)	11.81 (300)
H	14.96 (380)	17.71 (450)	19.69 (500)	23.62 (600)	27.56 (700)
D	9.45 (240)	10.83 (275)	11.81 (300)	13.78 (350)	15.75 (400)
K	21.65 (550)	25.98 (660)	29.13 (740)	35.43 (900)	41.73 (1060)

- Pitch = 1.42 (36 mm)
- Links/ft (m) = 8.45 (28)
- Dimensions E = .98 (25 mm)
- Ba = 3.78 (96 mm)

Triple Axis Movement, Series E333

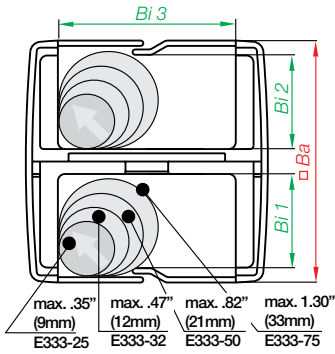

Part No. structure

E333-	50-	100-	0
-------	-----	------	---

- Color - black
- Bending radius
- Width
- Series

Part No.	Bi 1	Bi 2	Bi 3	Ba
E333-25- <input type="text"/> -0	.51 (13)	.51 (13)	.98 (25)	1.34 (34)
E333-32- <input type="text"/> -0	.69 (17.5)	.69 (17.5)	1.26 (32)	1.97 (50)
E333-50- <input type="text"/> -0	1.02 (26)	1.02 (26)	1.97 (50)	2.68 (68)
E333-75- <input type="text"/> -0	1.52 (38.5)	1.52 (38.5)	2.95 (75)	3.78 (96)

Supplement part number with required radius from above
for example, E333-32-100-0

Installation dimensions for triple-axis movement

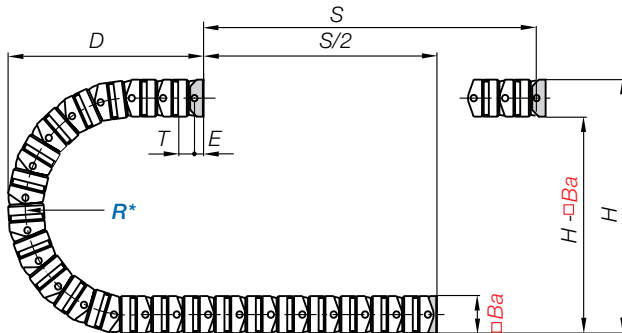

For center mount applications:
Chain length = $S/2 + K$

* The bending radii are doubled in the case of the **Series E333** e-chain®

Legend

- S = Length of travel
- R = Bending radius
- H = Nominal clearance height
- D = Overlength e-chain® radius in final position
- $K = \pi \cdot R + \text{"safety buffer"}$

Series E333-25--0

R	3.78 (96)	5.91 (150)	7.87 (200)	9.84 (250)	11.81 (300)	13.78 (350)	15.75 (400)
H	9.06 (230)	13.19 (335)	17.13 (435)	21.06 (535)	25.00 (635)	28.94 (735)	32.87 (835)
D	5.71 (145)	7.87 (200)	9.84 (250)	11.81 (300)	13.78 (350)	15.75 (400)	17.72 (450)
K	13.78 (350)	20.28 (515)	26.57 (675)	32.68 (830)	38.98 (990)	45.28 (1150)	51.18 (1300)

Pitch = .57 (14.5 mm)
Links/ft (m) = 21.03 (69)
Dimensions E = .39 (10 mm)
Ba = 1.34 (34 mm)

Series E333-32--0

R	5.91 (150)	7.87 (200)	9.84 (250)	11.81 (300)	15.75 (400)	19.69 (500)
H	13.78 (350)	17.72 (450)	21.65 (550)	25.59 (650)	33.46 (850)	41.33 (1050)
D	8.07 (205)	10.04 (255)	12.01 (305)	13.98 (355)	17.91 (455)	21.85 (555)
K	21.46 (545)	27.56 (700)	33.86 (860)	40.16 (1020)	51.18 (1300)	63.19 (1605)

Pitch = .98 (25 mm)
Links/ft (m) = 12.24 (40)
Dimensions E = .79 (20 mm)
Ba = 1.97 (50 mm)

Series E333-50--0

R	7.87 (200)	9.84 (250)	11.81 (300)	15.75 (400)	19.69 (500)
H	18.50 (470)	22.44 (570)	26.38 (670)	34.25 (870)	42.13 (1070)
D	11.61 (295)	13.58 (345)	15.55 (395)	19.49 (495)	23.42 (595)
K	29.53 (750)	35.83 (910)	42.13 (1070)	54.33 (1380)	66.54 (1690)

Pitch = 1.18 (30 mm)
Links/ft (m) = 10.17 (34)
Dimensions E = .98 (25 mm)
Ba = 2.68 (68 mm)

Series E333-75--0

R	11.02 (280)	13.78 (350)	15.75 (400)	19.69 (500)	23.62 (600)
H	25.98 (660)	31.50 (800)	35.43 (900)	43.31 (1100)	51.18 (1300)
D	14.96 (380)	17.72 (450)	19.69 (500)	23.62 (600)	27.56 (700)
K	38.98 (990)	47.64 (1210)	55.12 (1400)	66.93 (1700)	78.74 (2000)

Pitch = 1.42 (36 mm)
Links/ft (m) = 8.45 (28)
Dimensions E = .98 (25 mm)
Ba = 3.78 (96 mm)



Mounting Brackets

Option 1: KMA

- Corrosion resistant
- Strain relief with tie-wrap plate

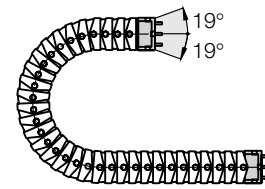

333-50-1PZB
Moving end
with tie-wrap plate

333-50-2PZB
Fixed end
(with tie-wrap plate
333-50-ZB)

333-50-1PZ

333-50-2PZB

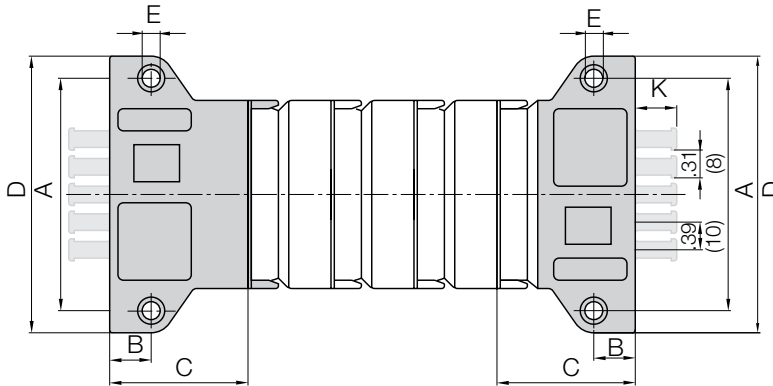

For high loads we recommend screwing the mounting brackets to the chain. If you have any questions, please give us a call.

Part No. structure

333-32-12 PZB

With assembled strain relief tie-wrap plates

Full set = 12

Mounting brackets for selected chain type

Full set, for both ends:

333-32-12 PZB + tie-wrap plate

Single-part order:

333-32-1 PZB + tie-wrap plate

Mounting bracket **with bore**

333-32-2 PZB + tie-wrap plate

Mounting bracket **with pin**

Series	Part No. without tie-wrap plate	Part No. with tie-wrap plate	A	B	C	D	E	K	N No. of Teeth
E331-25/E332-25-2/E333-25	333-25-12PZ	333-25-12PZB	1.69 (43)	.28 (7)	.87 (22)	2.04 (52)	.18 (4.5)	—	—
E331-32/E332-32-2/E333-32	333-32-12PZ	333-32-12PZB	2.60 (66)	.59 (15)	1.81 (46)	3.23 (82)	.26 (6.5)	.59 (15)	3
E331-50/E332-50-2/E333-50	333-50-12PZ	333-50-12PZB	3.31 (84)	.59 (15)	1.97 (50)	3.94 (100)	.26 (6.5)	.59 (15)	5
E331-75/E332-75-2/E333-75	333-75-12PZ	333-75-12PZB	4.29 (109)	.59 (15)	2.17 (55)	4.92 (125)	.26 (6.5)	.59 (15)	7

Mounting Brackets

Option 2: flange

- Galvanized steel
- Electrically conductive
- Flush mounting



330-25-1 – 330-75-1

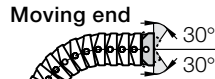

330-25-2 – 330-75-2

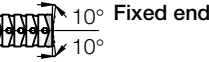

Part No. structure

330-	25-	12
------	-----	----

Full set = 12

Width

Mounting brackets for selected chain type

330-25-2 – 330-75-2

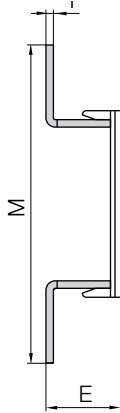

330-25-1 – 330-75-1

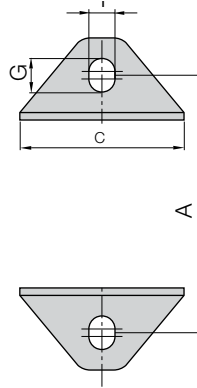

Full set, 4 parts

2 with pin / 2 with bore:

330-25-12

Single-part order:

330-25-1

Mounting bracket with bore

330-25-2

Mounting bracket with pin

Series	Part No.	A	M	C	L	T	E	F	G
E331-25/E332-25-2/E333-25	330-25-12	1.73 (44)	2.17 (55)	1.14 (29)	2.17 (55)	.06 (1.5)	.41 (10.5)	.26 (6.5)	.35 (9)
E331-32/E332-32-2/E333-32	330-32-12	2.60 (66)	3.31 (84)	1.73 (44)	3.46 (88)	.08 (2)	.79 (20)	.28 (7)	.35 (9)
E332-50/E332-50-2/E333-50	330-50-12	3.31 (84)	4.02 (102)	2.44 (62)	4.17 (106)	.08 (2)	.98 (25)	.28 (7)	.35 (9)
E331-75/E332-75-2/E333-75	330-75-12	4.29 (109)	5.00 (127)	3.54 (90)	5.16 (131)	.08 (2)	.98 (25)	.28 (7)	.35 (9)

Option 3: angle

- Galvanized steel
- Electrically conductive
- Can be attached to top or bottom of the machine



338-25-1/ 338-75-1

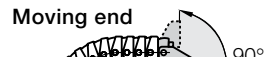

338-25-2 / 338-75-2

Fixed end

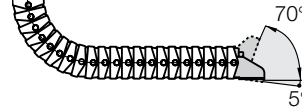

Part No. structure

338-	25-	12
------	-----	----

Full set = 12

Width

Mounting brackets for selected chain type

338-25-2 / 338-75-2

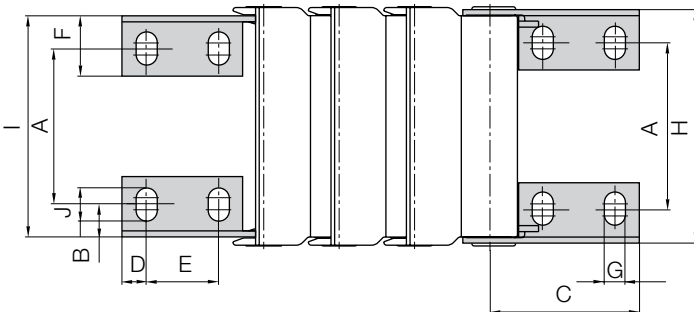

Full set, 4 parts

2 with pin / 2 with bore:

338-25-12

Single-part order:

338-25-1

Mounting bracket with bore

338-25-2

Mounting bracket with pin

Series	Part No.	A	B	C	D	E	F	G	H	I	J
E331-25/E332-25-2/E333-25	338-25-12	.67 (17)	.25 (6.25)	1.10 (28)	.24 (6)	.63 (16)	.55 (14)	.22 (5.5)	1.33 (33.8)	1.22 (31)	.33 (8.5)
E331-25/E332-32-2/E333-32	338-32-12	.94 (24)	.22 (5.5)	1.85 (47)	.31 (8)	.94 (24)	.79 (20)	.28 (7)	1.93 (49)	1.77 (45)	.43 (11)
E331-25/E332-50-2/E333-50	338-50-12	1.65 (42)	.22 (5.5)	3.03 (77)	.47 (12)	1.38 (35)	.94 (24)	.35 (9)	2.64 (67)	2.44 (62)	.59 (15)
E331-25/E332-75-2/E333-75	338-75-12	2.56 (65)	.22 (5.5)	3.03 (77)	.47 (12)	1.38 (35)	.94 (24)	.35 (9)	3.74 (95)	3.54 (90)	.59 (15)





igus[®] triflex[®]



triflex® - fully enclosed, for 2D and 3D applications

The triflex® series has been developed to safely guide cables during a 3D movement. In this case, the flexibility of a hose is combined with the stability of an e-chain® with a fixed, defined radius. This unique modular range enables very complex movements. As example: Combination of chain links moving in single, double and triple axes in an e-chain®.

Typical industries and applications

- Machine tools
- Robots
- Handling equipment
- Material handling
- Plastics machinery
- Construction machines
- Vehicles
- Machinery of all kinds
- Medical equipment



iF-Design awards for
1992 igus® series triflex®



Torsional motion
possible

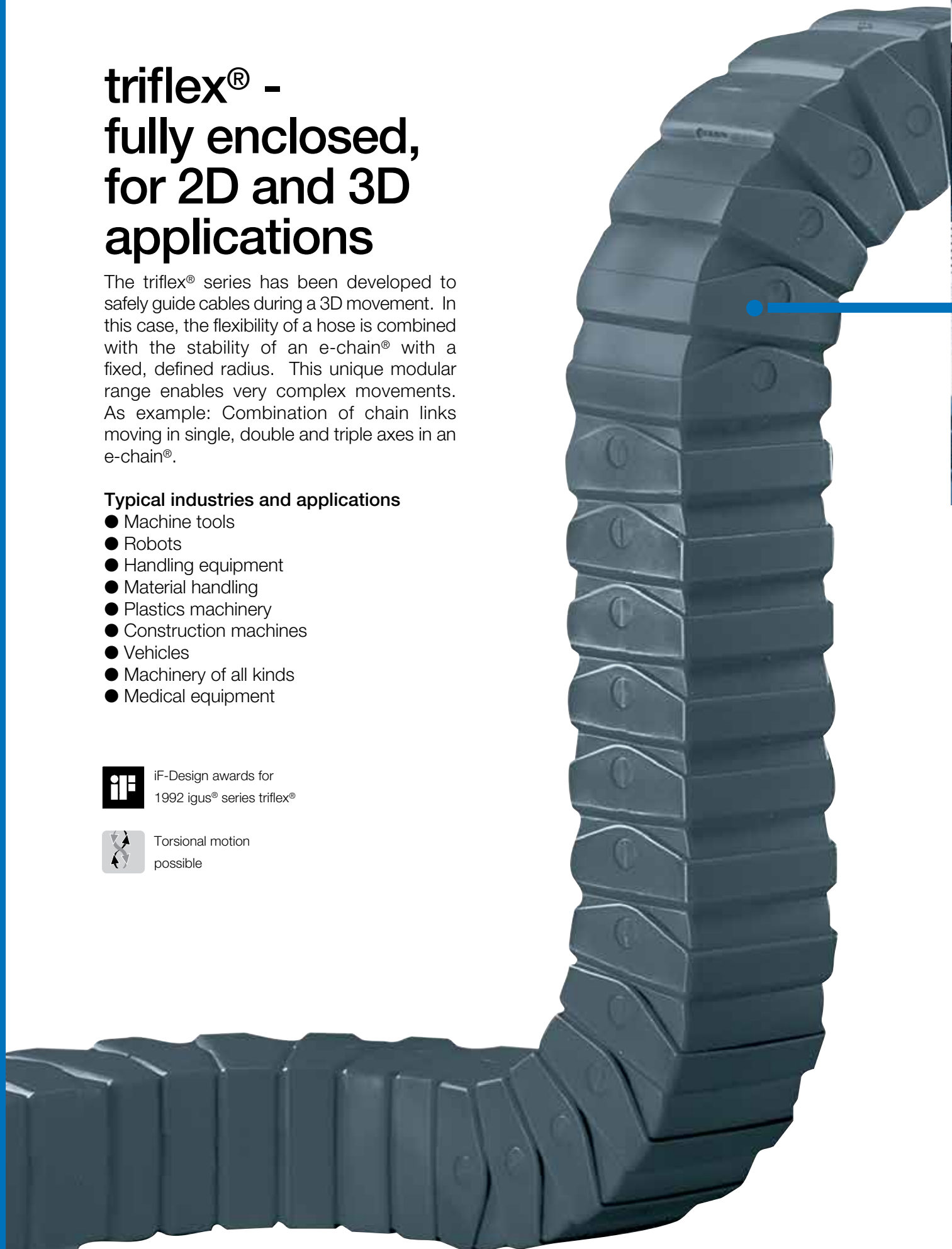

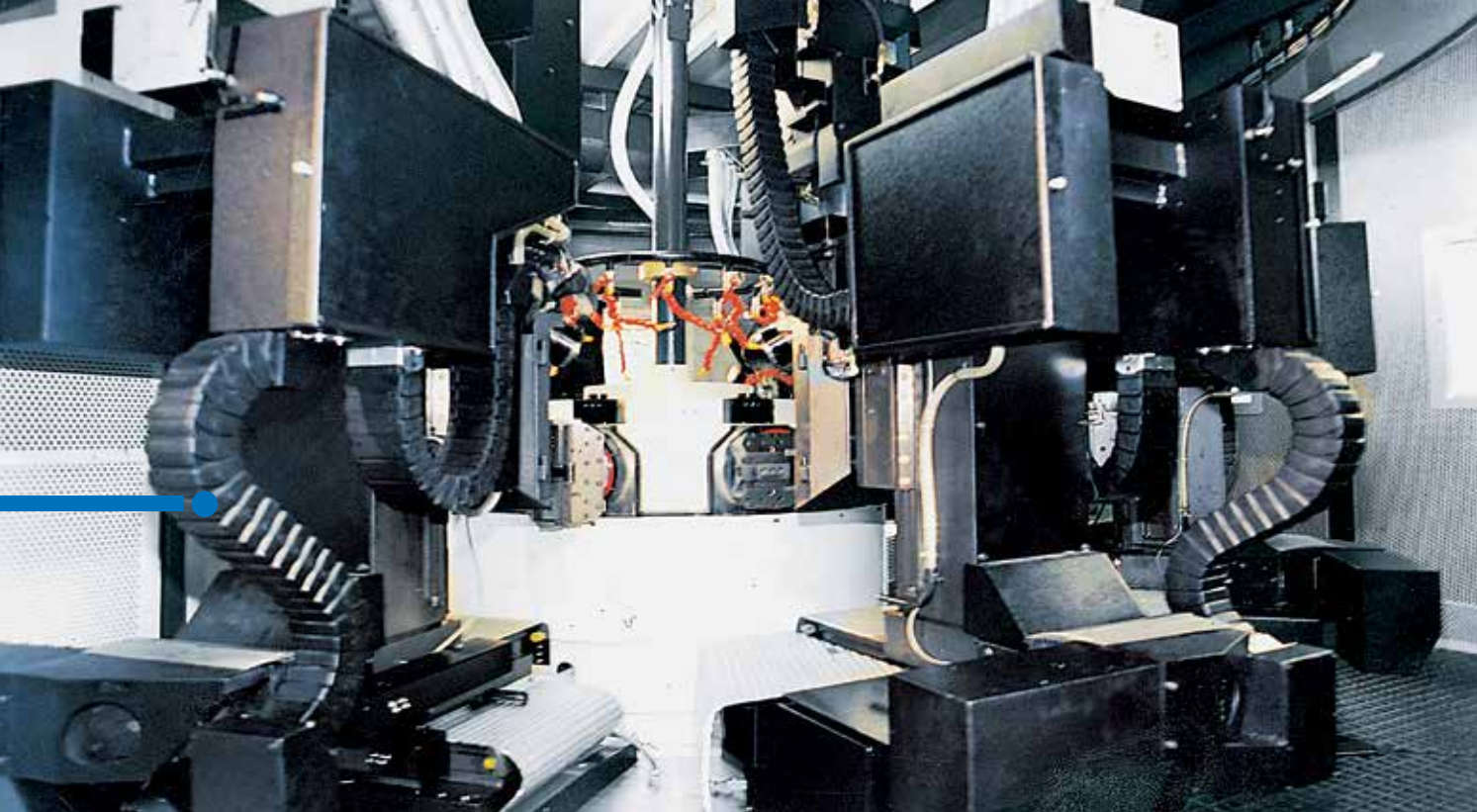

Various triflex® tubes on the inside of a machining center



triflex® for 3 movement directions combined with triflex® for 1 movement direction



triflex® 332 as unsupported link from machines to control desk

e-chain system® triflex® Series Selection Guide

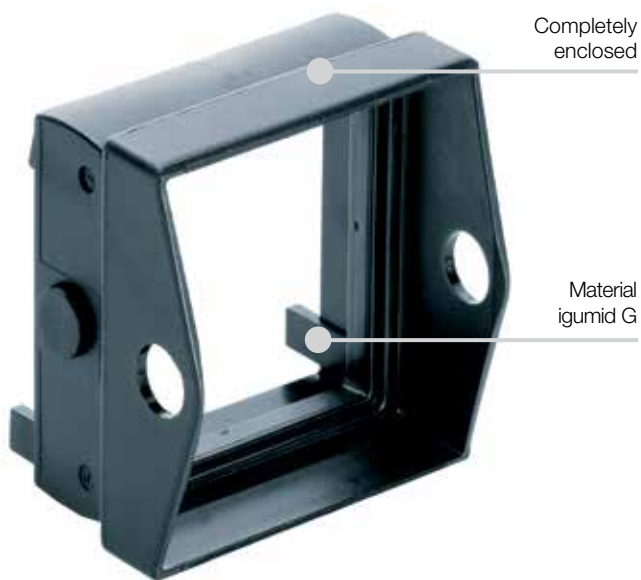

Select this modular, robust, Energy chain system® for:

- 3-axis motions in machinery of all kinds
- Dirty environments
- High tensile strength
- Where rectangular shapes fit better
- Side-mounted unsupported
- Completely enclosed - protection against dirt and chips
- Combinations of varying bending radii and moving axes
- Connecting and separating possible at every link
- Flanged mounting brackets or mounting brackets angle, galvanized steel
- Series 352 and 353 snap-open
- Combination Series 353/333 possible
- Cost-effective design for complex movements
- You can find more technical data about the material, chemical resistance, temperatures ► **Design, Chapter 1**

Selection table

Single-axis movement:

Series	Inner height/Inner width □ Bi		Outer width/Outer height □ Ba		Bending radii R	
	in.	(mm)	in.	(mm)	in.	(mm)
331-16	.63	(16)	1.02	(26)	1.50 - 3.94	(038 - 100)
331-32	1.26	(32)	1.97	(50)	2.95 - 9.84	(075 - 250)
331-50	1.97	(50)	2.68	(68)	3.94 - 9.84	(100 - 250)
331-75	2.95	(75)	3.78	(96)	5.51 - 11.81	(140 - 300)

Double-axis movement:

Series	Inner height/Inner width □ Bi		Outer width/Outer height □ Ba		Bending radii R	
	in.	(mm)	in.	(mm)	in.	(mm)
332-16	.63	(16)	1.02	(26)	1.50 - 3.94	(038 - 100)
332-32	1.26	(32)	1.97	(50)	2.95 - 9.84	(075 - 250)
332-50	1.97	(50)	2.68	(68)	3.94 - 9.84	(100 - 250)
332-75	2.95	(75)	3.78	(96)	5.51 - 11.81	(140 - 300)

Triple-axis movement:

Series	Inner height/Inner width □ Bi		Outer width/Outer height □ Ba		Bending radii R	
	in.	(mm)	in.	(mm)	in.	(mm)
333-16	.63	(16)	1.02	(26)	1.50 - 3.94	(038 - 100)
333-32	1.26	(32)	1.97	(50)	2.95 - 9.84	(075 - 250)
333-50	1.97	(50)	2.68	(68)	3.94 - 9.84	(100 - 250)
333-75	2.95	(75)	3.78	(96)	5.51 - 11.81	(140 - 300)

Snap-open Series:

Series	Inner height/Inner width □ Bi		Outer width/Outer height □ Ba		Bending radii R	
	in.	(mm)	in.	(mm)	in.	(mm)
351-50 Single	1.97	(50)	2.68	(68)	3.94 - 9.84	(100 - 250)
352-50 Double	1.97	(50)	2.68	(68)	3.94 - 9.84	(100 - 250)
353-50 Triple	1.97	(50)	2.68	(68)	3.94 - 9.84	(100 - 250)



Available from stock. Orders ship as early as today.*

*On average 90% of orders ship the same day..

e-chain system®

triflex® Series

Assembly Instructions

triflex® Series - Assembling



Twist and snap in



Snap in pin "push-button-design"

triflex® Series - Separating



Release side link



Twist and separate

triflex® Series 352 and 353 - Filling



To open Series 352 and Series 353 only - Insert screwdriver into slot on top of lid and push down

Price Index



Series 332/333 Series 352/353

Special Options Available



Flammability Class
VDE 0304 IIC UL94 V2



Torsion motion possible



iF-Design Award Winner

Assembly Tips



Release side link, twist and separate



To open Series 352 and Series 353 only
 - Insert screwdriver into slot on top of lid and push down

Usage Guidelines



- For applications that move within two or three axes (combined rotary and circular movements)
- If chip protection is required



- If every link must open on both sides

➤ TwisterChain® system,

Chapter 8

- For gliding applications
 - System E4, Chapter 6
- For rotary movements only
 - TwisterChain® system, Chapter 8

Features & Benefits

- 1 KMA, flanged and angled mounting brackets available
- 2 Combinations of varying bending radii and moving axes
- 3 Completely enclosed
- 4 Combination of Series 353 and Series 333 possible
- 5 Series 352 and 353 snap-open
- 6 Protection against dirt and chips
- 7 High tensile strength
- 8 Cost-effective design for complex movements
- 9 Assembling and separating at any given point

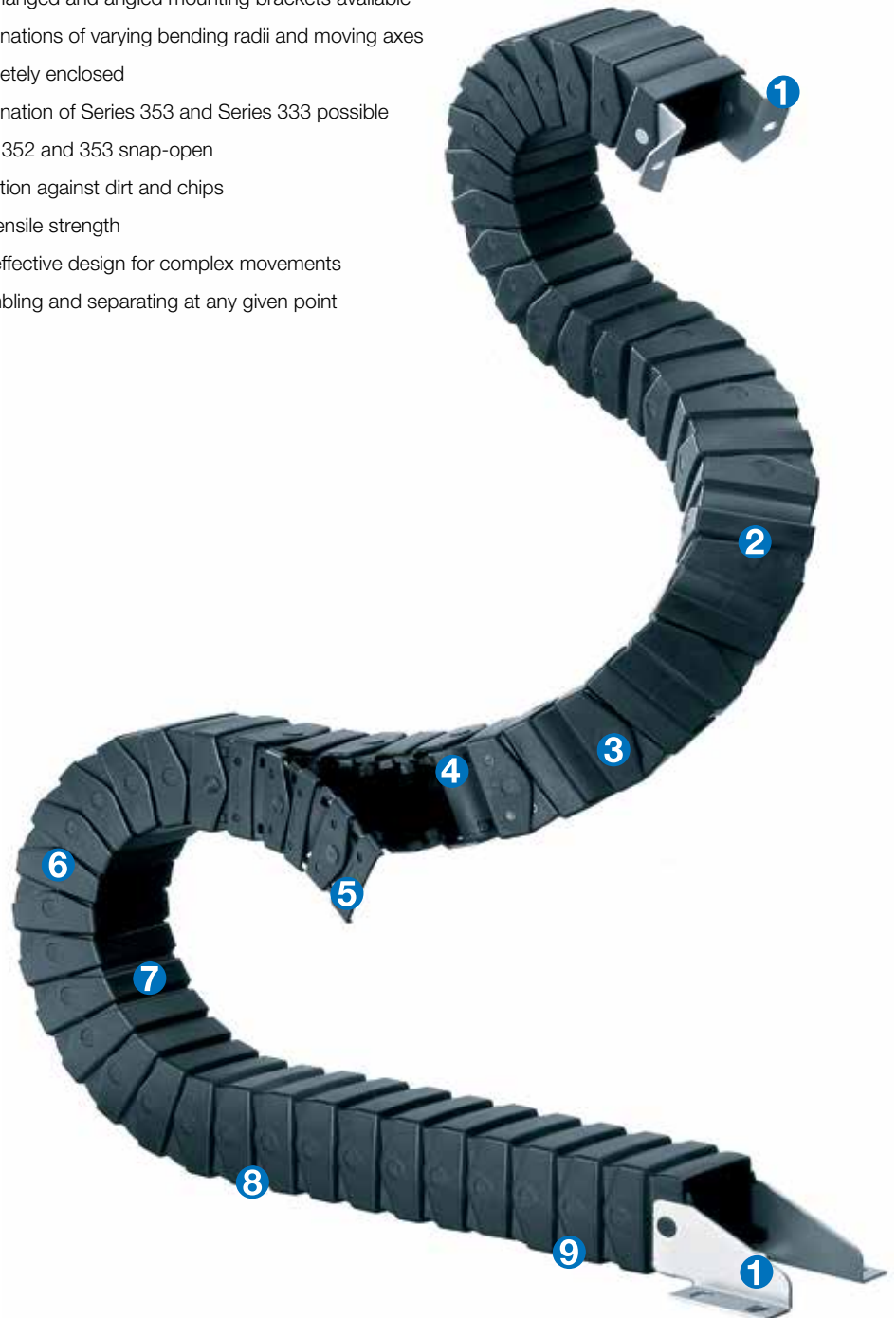

Order Example: Complete e-chain®

Please indicate chain length or number of links. Example:

6.56 ft (2 m) **332-50-100/100-0**

e-chain®

With 2 separators **351** assembled every 2nd link

Interior Separation

1 Set **338-50-12**

Mounting Bracket

e-chain system® triflex® Series
 Series 331/332/333
 Series 351/352/353 (Snap-Open)



triflex®

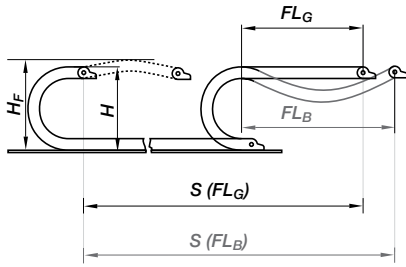

Short travel, unsupported length

- FL_B = unsupported with permitted sag
 - FL_G = unsupported with straight upper run
- Further information ► Design, Chapter 1

Legend

- S = Length of travel
- R = Bending radius
- H = Nominal clearance height
- D = Overlength e-chain® radius in final position
- $K = \pi \cdot R + \text{"safety buffer"}$
- H_F = Required clearance height

Unsupported length 331/332-16

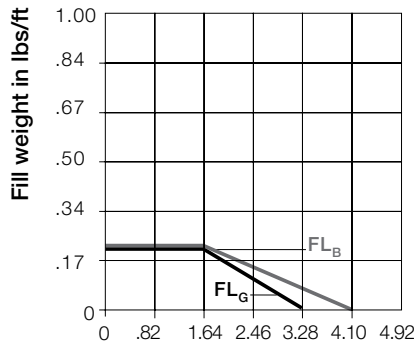

Unsupported length in ft FL_B/FL_G

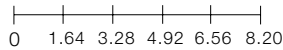

Total Length of travel S in ft

Unsupported length 331/332-32

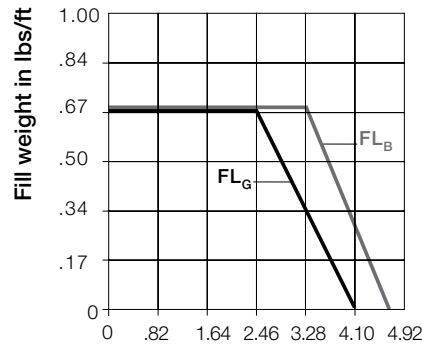

Unsupported length in ft FL_B/FL_G

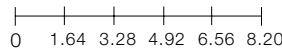

Total Length of travel S in ft

Unsupported length 331/332-50

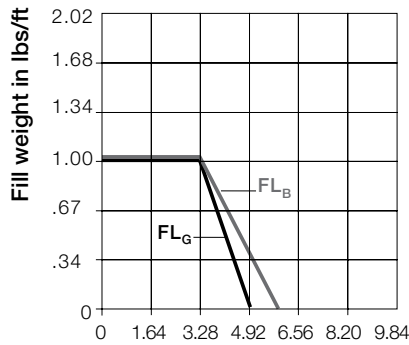

Unsupported length in ft FL_B/FL_G

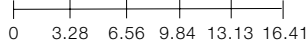

Total Length of travel S in ft

Unsupported length 331/332-75

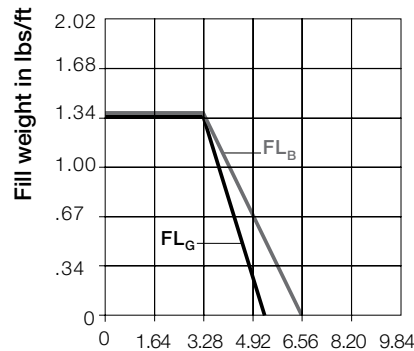

Unsupported length in ft FL_B/FL_G

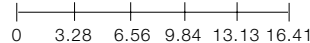

Total Length of travel S in ft

PDF: igus.com/e-chain-pdfs
 Product information: igus.com/e-chains



Technical Data

Material - permitted temperature
 Flammability Class, igumid NB

igumid G / -40°F (-40°C) up to +176°F (+80°C)
 VDE 0304 IIC UL94 V2



Details of material properties

► Chapter 1

Single Axis Movement, Series 331/351

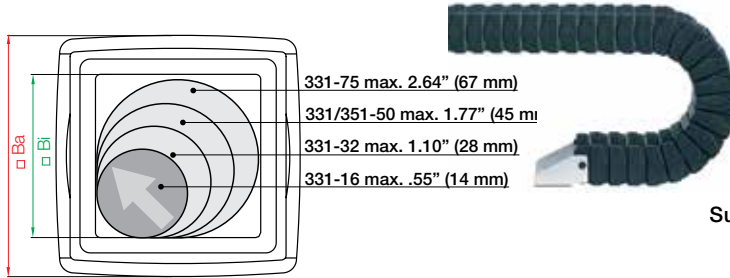

Part No.	Bi	Ba	Weight
	in. (mm)	in. (mm)	lbs/ft (kg/m)
331-16-	.63 (16)	1.02 (26)	≈ 0.22 (.33)
331-32-	1.26 (32)	1.97 (50)	≈ 0.60 (.90)
331-50-	1.97 (50)	2.68 (68)	≈ 0.94 (1.40)
331-75-	2.95 (75)	3.78 (96)	≈ 1.58 (2.35)
Snap-open			
351-50-	1.97 (50)	2.68 (68)	≈ 0.94 (1.40)

Supplement part number with required radius from below.
for example 331-50-100-0

Installation dimensions for single-axis movement

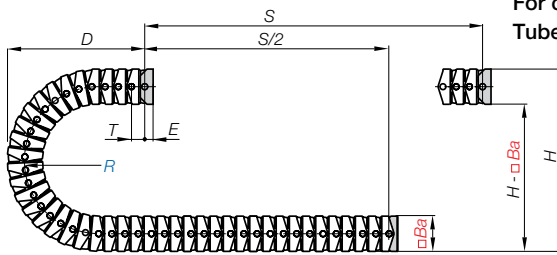

Part No. structure

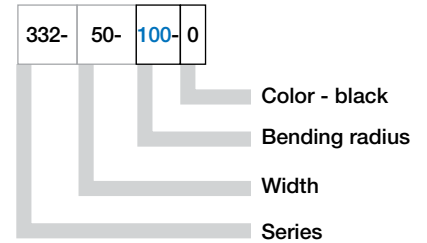

Series 331-16

R	1.50 (038)	1.89 (048)	2.95 (075)	3.94 (100)
H	4.13 (105)	4.92 (125)	7.09 (180)	9.06 (230)
D	2.76 (70)	3.15 (80)	4.13 (105)	5.12 (130)
K	7.87 (200)	9.06 (230)	12.40 (315)	15.75 (400)

Pitch = .52 (13.3 mm)
Links/ft (m) = 23.08 (76)
Dimensions E = .39 (10 mm)
Ba = 1.02 (26 mm)

Series 331-32

R	2.95 (075)	3.94 (100)	4.92 (125)	5.91 (150)	7.87 (200)	9.84 (250)
H	7.87 (200)	9.84 (250)	11.81 (300)	13.78 (350)	17.72 (450)	21.65 (550)
D	5.12 (130)	6.10 (155)	7.09 (180)	8.07 (205)	10.04 (255)	12.01 (305)
K	12.01 (305)	15.15 (385)	18.30 (465)	21.46 (545)	27.56 (700)	34.06 (865)

Pitch = .98 (25 mm)
Links/ft (m) = 12.24 (40)
Dimensions E = .79 (20 mm)
Ba = 1.97 (50 mm)

Series 331-50

R	3.94 (100)	4.92 (125)	5.91 (150)	7.87 (200)	9.84 (250)
H	10.63 (270)	12.60 (320)	14.76 (375)	18.50 (470)	22.44 (570)
D	7.68 (195)	8.66 (220)	9.65 (245)	11.61 (295)	13.58 (345)
K	17.13 (435)	20.47 (520)	23.23 (590)	29.53 (750)	35.83 (910)

Pitch = 1.18 (30 mm)
Links/ft (m) = 10.17 (34)
Dimensions E = .98 (25 mm)
Ba = 2.68 (68 mm)

Series 331-75

R	5.51 (140)	6.89 (175)	7.87 (200)	9.84 (250)	11.81 (300)
H	14.96 (380)	17.71 (450)	19.69 (500)	23.62 (600)	27.56 (700)
D	9.45 (240)	10.83 (275)	11.81 (300)	13.78 (350)	15.75 (400)
K	21.65 (550)	25.98 (660)	29.13 (740)	35.43 (900)	41.73 (1060)

Pitch = 1.42 (36 mm)
Links/ft (m) = 8.45 (28)
Dimensions E = .98 (25 mm)
Ba = 3.78 (96 mm)

Series 351-50 (Snap-Open)

R	3.94 (100)	4.92 (125)	5.91 (150)	7.87 (200)	9.84 (250)
H	10.63 (270)	12.60 (320)	14.76 (375)	18.50 (470)	22.44 (570)
D	7.68 (195)	8.66 (220)	9.65 (245)	11.61 (295)	13.58 (345)
K	17.13 (435)	20.47 (520)	23.23 (590)	29.53 (750)	35.83 (910)

Pitch = 1.18 (30 mm)
Links/ft (m) = 10.17 (34)
Dimensions E = .98 (25 mm)
Ba = 2.68 (68 mm)

Double Axis Movement, Series 332/352

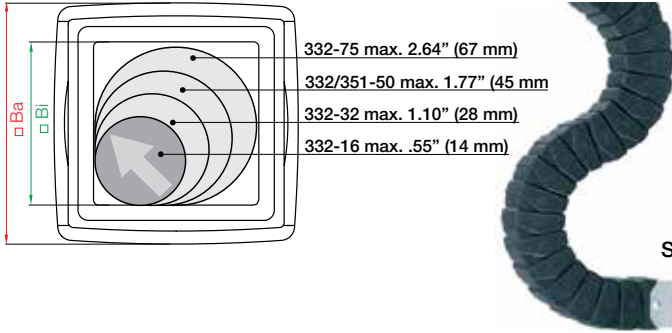

Part No.	Bi in. (mm)	Ba in. (mm)	Weight lbs/ft (kg/m)
332-16-	.63 (16)	1.02 (26)	≈ 0.22 (.33)
332-32-	1.26 (32)	1.97 (50)	≈ 0.60 (.90)
332-50-	1.97 (50)	2.68 (68)	≈ 0.94 (1.40)
332-75-	2.95 (75)	3.78 (96)	≈ 1.58 (2.35)
Snap-open			
352-50-	1.97 (50)	2.68 (68)	≈ 0.94 (1.40)

Supplement part number with required radius from below
for example, 332-75-2-200-0

Installation dimensions for double-axis movement

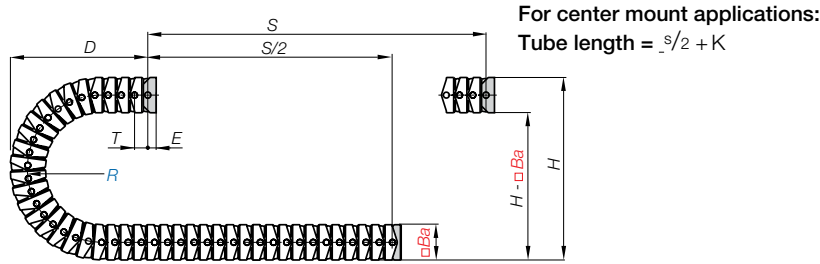

Part No. structure

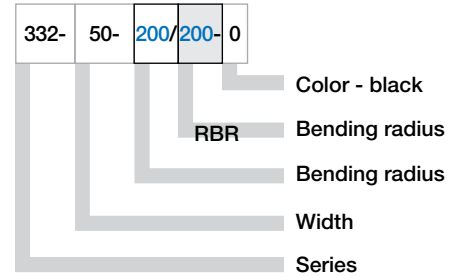

Series 332-16

R	1.50 (038)	1.89 (048)	2.95 (075)	3.94 (100)
H	4.13 (105)	4.92 (125)	7.09 (180)	9.06 (230)
D	2.76 (70)	3.15 (80)	4.13 (105)	5.12 (130)
K	7.87 (200)	9.06 (230)	12.40 (315)	15.75 (400)

Pitch = .52 (13.3 mm)
Links/ft (m) = 23.08 (76)
Dimensions E = .39 (10 mm)
Ba = 1.02 (26 mm)

Series 332-32

R	2.95 (075)	3.94 (100)	4.92 (125)	5.91 (150)	7.87 (200)	9.84 (250)
H	7.87 (200)	9.84 (250)	11.81 (300)	13.78 (350)	17.72 (450)	21.65 (550)
D	5.12 (130)	6.10 (155)	7.09 (180)	8.07 (205)	10.04 (255)	12.01 (305)
K	12.01 (305)	15.15 (385)	18.30 (465)	21.46 (545)	27.56 (700)	34.06 (865)

Pitch = .98 (25 mm)
Links/ft (m) = 12.24 (40)
Dimensions E = .79 (20 mm)
Ba = 1.97 (50 mm)

Series 332-50

R	3.94 (100)	4.92 (125)	5.91 (150)	7.87 (200)	9.84 (250)
H	10.63 (270)	12.60 (320)	14.76 (375)	18.50 (470)	22.44 (570)
D	7.68 (195)	8.66 (220)	9.65 (245)	11.61 (295)	13.58 (345)
K	17.13 (435)	20.47 (520)	23.23 (590)	29.53 (750)	35.83 (910)

Pitch = 1.18 (30 mm)
Links/ft (m) = 10.17 (34)
Dimensions E = .98 (25 mm)
Ba = 2.68 (68 mm)

Series 332-75

R	5.51 (140)	6.89 (175)	7.87 (200)	9.84 (250)	11.81 (300)
H	14.96 (380)	17.71 (450)	19.69 (500)	23.62 (600)	27.56 (700)
D	9.45 (240)	10.83 (275)	11.81 (300)	13.78 (350)	15.75 (400)
K	21.65 (550)	25.98 (660)	29.13 (740)	35.43 (900)	41.73 (1060)

Pitch = 1.42 (36 mm)
Links/ft (m) = 8.45 (28)
Dimensions E = .98 (25 mm)
Ba = 3.78 (96 mm)

Series 352-50 (Snap-Open)

R	3.94 (100)	4.92 (125)	5.91 (150)	7.87 (200)	9.84 (250)
H	14.96 (380)	12.60 (320)	14.76 (375)	18.50 (470)	22.44 (570)
D	9.45 (240)	8.66 (220)	9.65 (245)	11.61 (295)	13.58 (345)
K	21.65 (550)	20.47 (520)	23.23 (590)	29.53 (750)	35.83 (910)

Pitch = 1.18 (30 mm)
Links/ft (m) = 10.17 (34)
Dimensions E = .98 (25 mm)
Ba = 2.68 (68 mm)



Triple Axis Movement, Series 333/353 (Snap-Open)

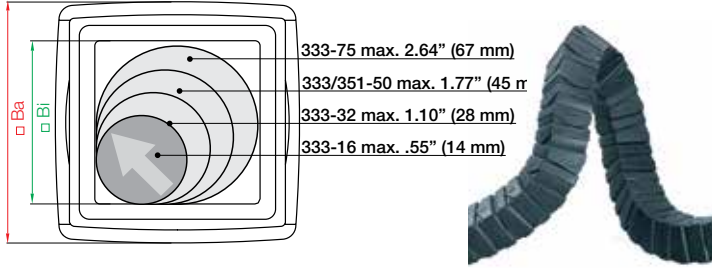

Part No.	Bi in. (mm)	Ba in. (mm)	Weight lbs/ft (kg/m)
333-16-	.63 (16)	1.02 (26)	≈ 0.22 (.33)
333-32-	1.26 (32)	1.97 (50)	≈ 0.60 (.90)
333-50-	1.97 (50)	2.68 (68)	≈ 0.94 (1.40)
333-75-	2.95 (75)	3.78 (96)	≈ 1.58 (2.35)
Snap-open			
353-50-	1.97 (50)	2.68 (68)	≈ 0.94 (1.40)

Supplement part number with required radius from above
for example, 333-32-100-0

Installation dimensions for triple-axis movement

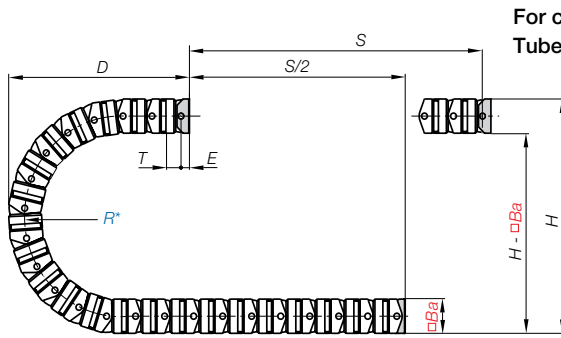

For center mount applications:
Tube length = $\frac{S}{2} + K$

Part No. structure

333-	50-	100-	0
------	-----	------	---

- Color - black
- RBR — Bending radius
- Width
- Series

* The bending radii are doubled in the case of the **Series 333** e-chain®

Series 333-16

R	(076)	3.78 (096)	5.91 (150)	7.87 (200)
H	7.09 (180)	8.66 (220)	12.99 (330)	16.93 (430)
D	4.13 (105)	4.92 (125)	7.09 (180)	9.06 (230)
K	12.60 (320)	14.96 (380)	21.65 (550)	27.95 (710)

Pitch = .52 (13.3 mm)
Links/ft (m) = 23.08 (76)
Dimensions E = .39 (10 mm)
Ba = 1.02 (26 mm)

Series 333-32

R	5.91 (150)	7.87 (200)	9.84 (250)	11.81 (300)	15.75 (400)	19.69 (500)
H	13.78 (350)	17.72 (450)	21.65 (550)	25.59 (650)	33.46 (850)	41.33 (1050)
D	8.07 (205)	10.04 (255)	12.01 (305)	13.98 (355)	17.91 (455)	21.85 (555)
K	21.46 (545)	27.56 (700)	33.86 (860)	40.16 (1020)	51.18 (1300)	63.19 (1605)

Pitch = .98 (25 mm)
Links/ft (m) = 12.24 (40)
Dimensions E = .79 (20 mm)
Ba = 1.97 (50 mm)

Series 333-50

R	7.87 (200)	9.84 (250)	11.81 (300)	15.75 (400)	19.69 (500)
H	18.50 (470)	22.44 (570)	26.38 (670)	34.25 (870)	42.13 (1070)
D	11.61 (295)	13.58 (345)	15.55 (395)	19.49 (495)	23.43 (595)
K	29.53 (750)	35.83 (910)	42.13 (1070)	54.33 (1380)	66.54 (1690)

Pitch = 1.18 (30 mm)
Links/ft (m) = 10.17 (34)
Dimensions E = .98 (25 mm)
Ba = 2.68 (68 mm)

Series 333-75

R	11.02 (280)	13.78 (350)	15.75 (400)	19.69 (500)	23.62 (600)
H	25.98 (660)	31.50 (800)	35.43 (900)	43.31 (1100)	51.18 (1300)
D	14.96 (380)	17.72 (450)	19.69 (500)	23.62 (600)	27.56 (700)
K	38.98 (990)	47.64 (1210)	55.12 (1400)	66.93 (1700)	78.74 (2000)

Pitch = 1.42 (36 mm)
Links/ft (m) = 8.45 (28)
Dimensions E = .98 (25 mm)
Ba = 3.78 (96 mm)

Series 353-50 (Snap-Open)

R	7.87 (200)	9.84 (250)	11.81 (300)	15.75 (400)	19.69 (500)
H	18.50 (470)	22.44 (570)	26.38 (670)	34.25 (870)	42.13 (1070)
D	11.61 (295)	13.58 (345)	15.55 (395)	19.49 (495)	23.43 (595)
K	29.53 (750)	35.83 (910)	42.13 (1070)	54.33 (1380)	66.54 (1690)

Pitch = 1.18 (30 mm)
Links/ft (m) = 10.17 (34)
Dimensions E = .98 (25 mm)
Ba = 2.68 (68 mm)

Interior Separation

Modular separators are available as interior shelving for the igus® triflex® System. They can be used for both vertical and horizontal sub-division. If the separators are assembled every other link and turned 90°, the tube can be sub-divided into four segments. We recommend ordering the tube pre-assembled, as subsequent assembly of separators is only possible after dismantling the tube. Please note that assembled separators have a different part number than unassembled separators.



Horizontal sub-division



Vertical sub-division

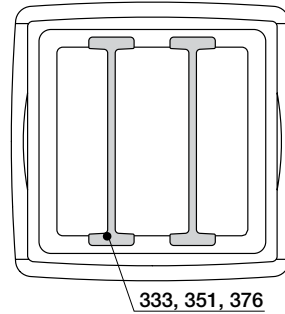

331/332/333-75

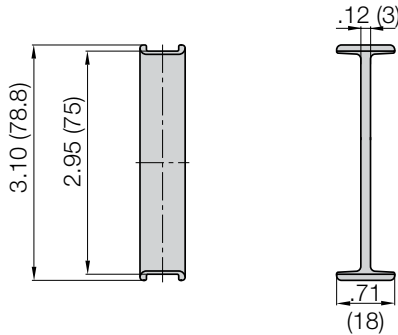

Separator

Unassembled	Part No. 375
Assembled	Part No. 376

331/332/333-50 351/352/353-50

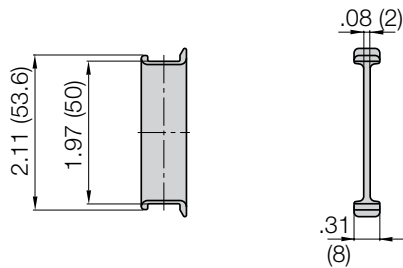

Separator

Unassembled	Part No. 350
Assembled	Part No. 351

331/332/333-32

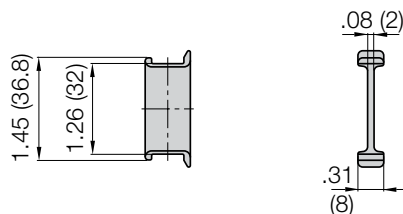

Separator

Unassembled	Part No. 332
Assembled	Part No. 333





Standard

Option 1: KMA

- Corrosion resistant
- Strain relief with tiwrap plate

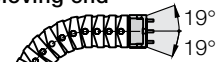
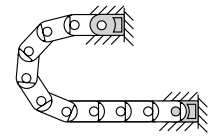
333-50-1PZ
Moving end333-50-2PZB
Fixed end
(with tiwrap plate 333-50-ZB)

Possible installation configurations -

333...1PZ(B)

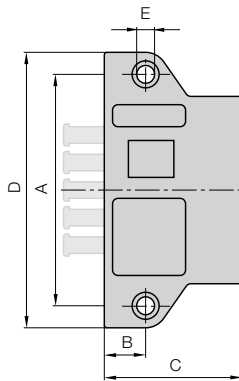

333...2PZ(B)

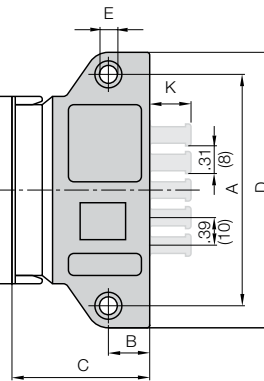

For high loads we recommend screwing the mounting brackets to the chain. If you have any questions, please give us a call.

Part No. structure

333-32-12-PZB

With assembled strain relief tiwrap plates

Full set = 12

Mounting brackets for selected chain type

Full set, for both ends:

333-32-12PZB +tiwrap plate

Single-part order:

333-32-1PZB +tiwrap plate

Mounting bracket with bore

333-32-2PZB +tiwrap plate

Mounting bracket with pin

Series	Part No. Full Set with tiwrap plate	Part No. Full Set without tiwrap plate	A	B	C	D	E	K	N
			in. (mm)	in. (mm)	in. (mm)	in. (mm)	in. (mm)	in. (mm)	No. of Teeth
331/332/333-32	333-32-12PZB	333-32-12-PZ	2.60 (66)	.59 (15)	1.81 (46)	3.23 (82)	.26 (6.5)	.59 (15)	3
331/332/333-50	333-50-12PZB	333-50-12-PZ	3.31 (84)	.59 (15)	1.97 (50)	3.94 (100)	.26 (6.5)	.59 (15)	5
331/332/333-75	333-75-12PZB	333-75-12-PZ	4.29 (109)	.59 (15)	2.17 (55)	4.92 (125)	.26 (6.5)	.59 (15)	7
Snap-open series									
351/352/353-50	333-50-12PZB	333-50-12-PZ	3.31 (84)	.59 (15)	1.97 (50)	3.94 (100)	.26 (6.5)	.59 (15)	5

Tiwrap plate as individual part

Special tiwrap plates for triflex® e-chains®

- Single-piece for installation inside switch cabinets or machine assembly
- Accessory for igus® e-chain systems®
- Easy to assemble, no need for screws

Part No.	Width	Number	For Series
Tiwrap plate	in. (mm)	of teeth	
333-32-ZB	1.57 (40)	3	331/332/333-32
333-50-ZB	2.28 (58)	5	331/332/333-50 351/352/353-50
333-75-ZB	3.27 (83)	7	331/332/333-75

e-chain system® triflex® Series Mounting Brackets



triflex®



Option 2: pivoting steel flange

- Galvanized steel
- Electrically conductive
- Flush mounting

330-16-1 / 330-75-1

Moving end

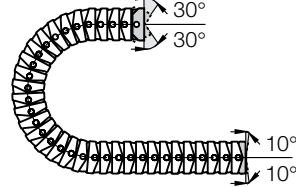

330-16-2 / 330-75-2

Fixed end



Possible installation configurations -

Full set, 4 parts

2 with pin / 2 with bore:

330-32-12

Single-part order:

330-32-1

Mounting bracket with bore

330-32-2

Mounting bracket with pin

Part No. structure

330- 32- 12

Full set = 12

Width

Mounting brackets for selected chain type

330-26-2 / 330-75-2

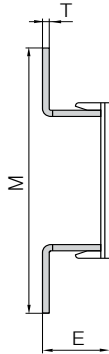

330-16-1 / 330-75-1

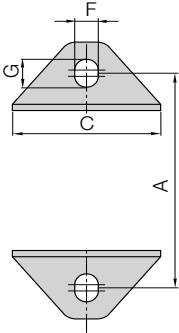

Series	Part No.	A	M	C	L	T	E	F	G
331/332/333-16	330-16-12	1.38 (35)	2.09 (53)	.83 (21)	2.24 (57)	.04 (1)	.39 (10)	.18 (4.5)	.24 (6)
331/332/333-32	330-32-12	2.60 (66)	3.31 (84)	1.73 (44)	3.46 (88)	.08 (2)	.79 (20)	.28 (7)	.35 (9)
331/332/333-50	330-50-12	3.31 (84)	4.02 (102)	2.44 (62)	4.17 (106)	.08 (2)	.98 (25)	.28 (7)	.35 (9)
331/332/333-75	330-75-12	4.29 (109)	5.00 (127)	3.54 (90)	5.16(131)	.08 (2)	.98 (25)	.28 (7)	.35 (9)



Option 3: angle

- Galvanized steel
- Electrically conductive
- Can be attached to top or bottom of the machine

338-16-1 / 338-75-1

Moving end

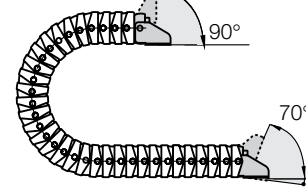

338-16-2 / 338-75-2

Fixed end



Possible installation configurations -

Full set, 4 parts

2 with pin / 2 with bore:

338-32-12

Single-part order:

338-32-1

Mounting bracket with bore

338-32-2

Mounting bracket with pin

Part No. structure

338- 32- 12

Full set = 12

Width

Mounting brackets for selected chain type

338-16-2 / 338-75-2



338-16-1 / 338-75-1

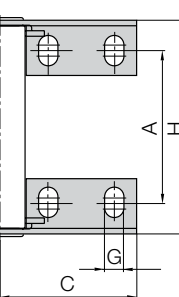

Series	Part No.	A	B	C	D	E	F	G	H	I	J
331/332/333-16	338-16-12	.47 (12)	.12 (3)	.98 (25)	.20 (5)	.39 (10)	.43 (11)	18 (4,5)	.98 (25)	.91 (23)	.24 (6)
331/332/333-32	338-32-12	.94 (24)	.22 (5.5)	1.85 (47)	.31 (8)	.94 (24)	.79 (20)	.28 (7)	1.93 (49)	1.77 (45)	.43 (11)
331/332/333-50	338-50-12	1.65 (42)	.22 (5.5)	3.03 (77)	.47 (12)	1.38 (35)	.94 (24)	.35 (9)	2.64 (67)	2.44 (62)	.59 (15)
331/332/333-75	338-75-12	2.56 (65)	.22 (5.5)	3.03 (77)	.47 (12)	1.38 (35)	.94 (24)	.35 (9)	3.74 (95)	3.54 (90)	.59 (15)
Snap-open											
351/352/353-50	338-50-12	1.65 (42)	.22 (5.5)	3.03 (77)	.47 (12)	1.38 (35)	.94 (24)	.35 (9)	2.64 (67)	2.44 (62)	.59 (15)

PDF: igus.com/e-chain-pdfs
Product information: igus.com/e-chains

